

Palladium Books® Presents:

Rifts® Dimension Book™ Eight:

Naruni™ Wave 2

By Bellaire, Nowak, Rosenstein & Stambleda

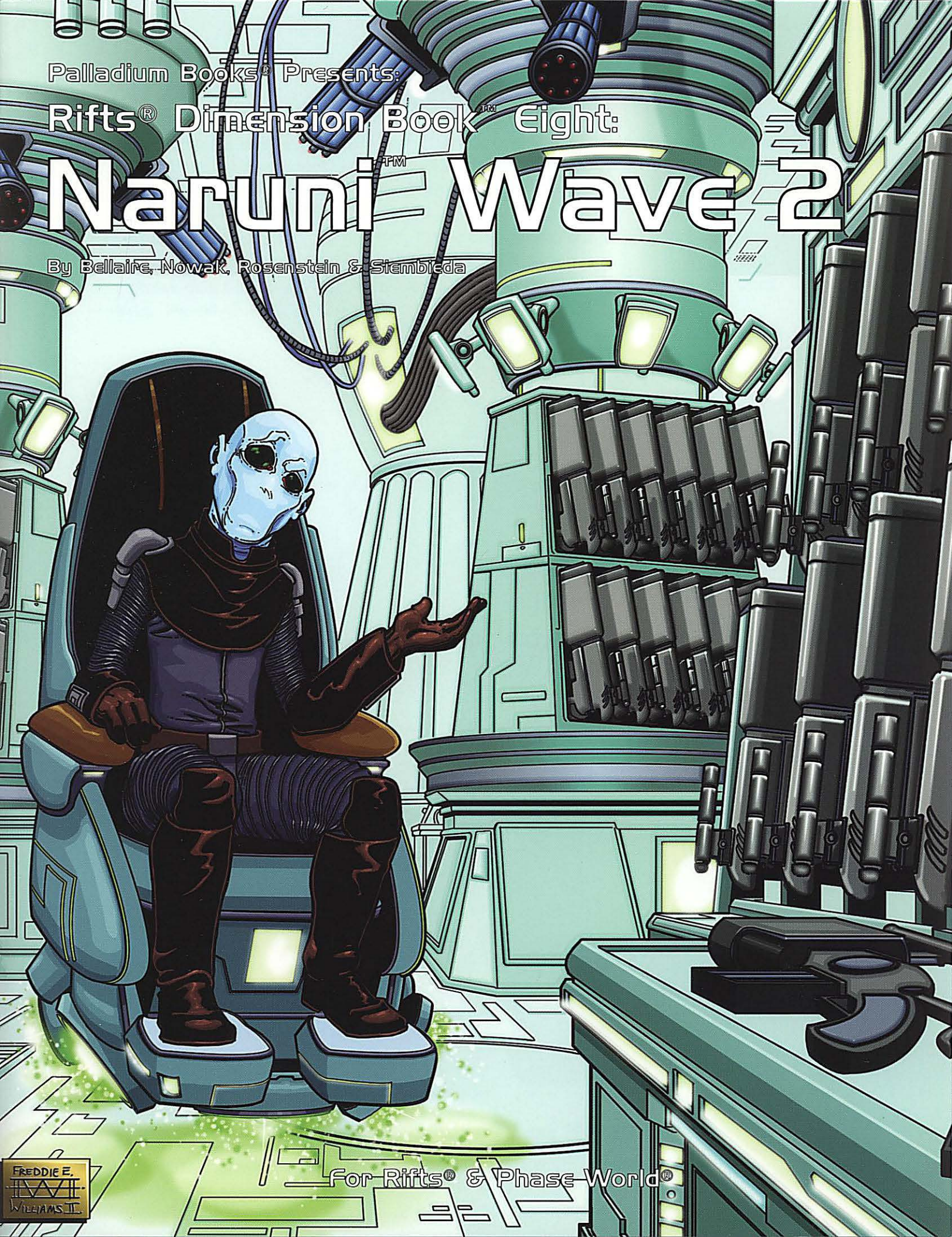

FREDDIE E.
WILLIAMS II

For Rifts® & Phase World®

Warning!

Violence, War, Magic & the Supernatural

The fictional worlds of *Rifts*® and *Phase World*® are violent, deadly and filled with aliens, war and supernatural monsters. Other-dimensional beings often referred to as “demons,” torment, stalk and prey on humans. Alien life forms, monsters, gods and demigods, as well as magic, insanity, and combat are all elements in this book.

Some parents may find the violence, magic and supernatural elements of the game inappropriate for young readers/players. We suggest parental discretion.

Please note that none of us at Palladium Books® condone or encourage the occult, the practice of magic, the use of drugs, or violence.

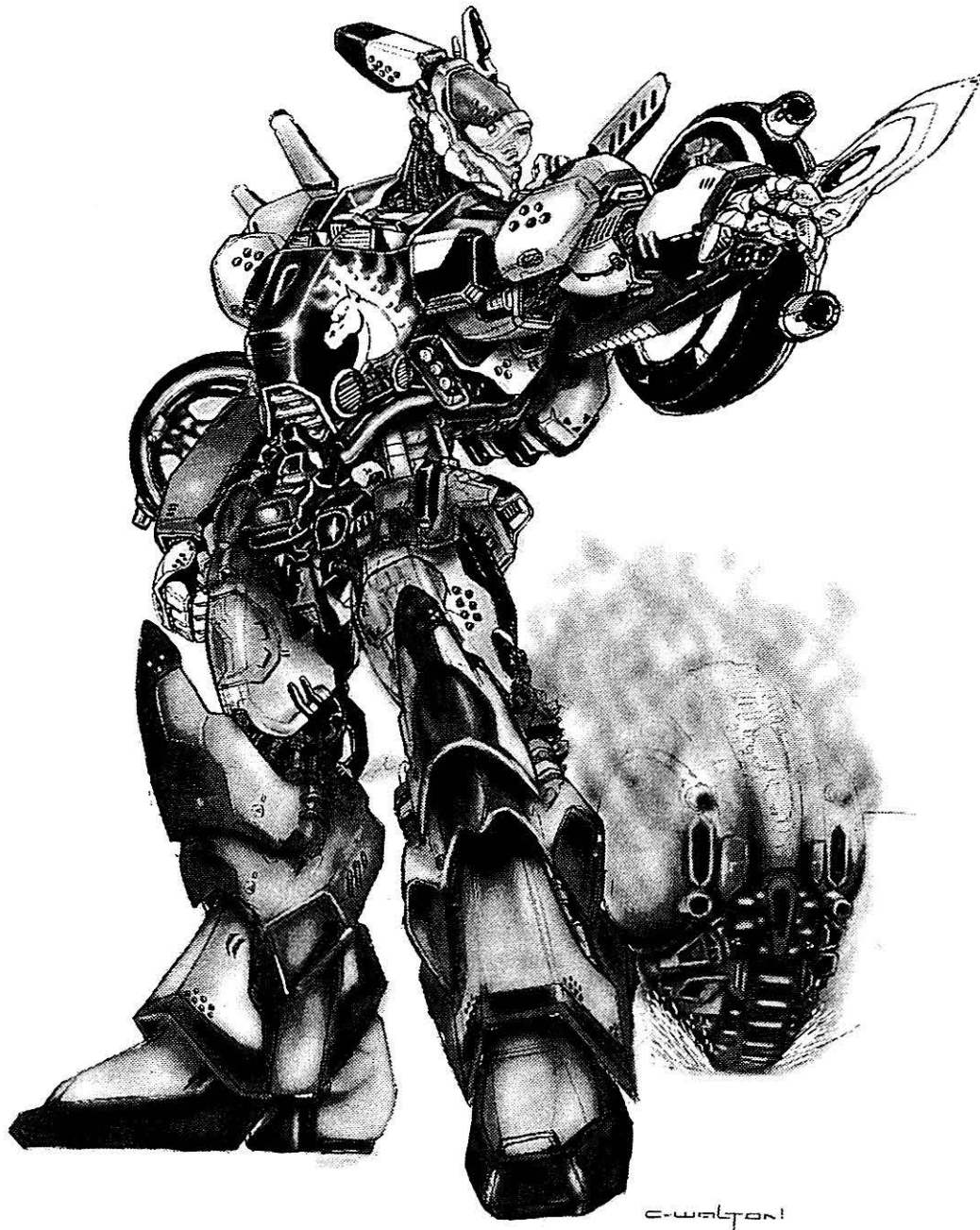

An epic sourcebook for the *Rifts*® and *Phase World*® Series.
Compatible with the entire Palladium Books® Megaverse®

Dedication

I want to dedicate this book to Paul Deckert, Rene Vega, Chuck Knakal, Erick Todd, Kay Kozora, Sophie Bartold, Erick, Hank, Brian, Skip, Louie, Thom, Ken, Steve, Alex, Julius, and everybody else who has been there for me and Palladium Books, past and present. Each and every one of you played a role in helping this growing enterprise soar into the new Millennium. Thanks, you are in my heart always.

And to Pat Nowak, an imaginative gamer, writer and heck of a guy. It's good to have you back in the world, healthy and whole.

– Kevin Siembieda, April 2004

The cover, by *Freddie Williams II*, depicts an Uteni sales rep from Naruni Enterprises showing off his most recent shipment of weapons at one of the secret showrooms in North America – power armor, robots and vehicles are around the corner.

First Printing – April 2004

No part of this publication may be scanned, OCR'd or reproduced in any way for electronic publication on the web/internet or any other medium.

Copyright 2004 Palladium Books Inc. & Kevin Siembieda

All rights reserved, worldwide, under the Universal Copyright Convention. No part of this book may be reproduced in part or whole, in any form or by any means, without permission from the publisher, except for brief quotes for use in reviews. All incidents, situations, institutions, governments and people are fictional and any similarity, without satiric intent, of characters or persons living or dead, is strictly coincidental.

Rifts®, The Rifter®, Phase World®, Megaverse®, The Mechanoids®, The Mechanoid Invasion®, After the Bomb®, Coalition Wars® and Palladium Books® are registered trademarks owned and licensed by Palladium Books Inc. and Kevin Siembieda.

Naruni Enterprises, Naruni, Thermo-Kinetic, Sun Chariot, Uteni, Molock, Northern Gun, Manistique Imperium, Wilk's, Arzno, Coalition States, CS, Free Quebec, Tolkeen, Federation of Magic, the 'Burbs, Chi-Town, The Three Galaxies, Thundercloud Galaxy, Anvil Galaxy, Corkscrew Galaxy, Chaos Earth, Heroes Unlimited, Aliens Unlimited, Rifts® Game Master Guide, Rifts® Book of Magic, Rifts® Mercenaries, Splynn Dimensional Market, Dinosaur Swamp, Rifts Earth, Cosmo-Knights, Cosmic Forge, Cyber-Knights, Repo-Bots, Wolfen, Juicer, Crazy, Shifter, Biomancer, Bio-Wizardry, Ley Line Walker, Mind Melter, Tattooed Man, Maxi-Man, Undead Slayer, Techno-Wizard, Temporal Raider, 'Borg, Bio-Borg, 'Bot, Cyber-Doc, Bioware, Headjack, Full Conversion Cyborg, Headhunter, Archie-3, E-Clip, Mega-Damage, M.D.C., S.D.C., I.S.P., P.P.E., Splugorth, Splugorth Slaver, Splugorth High Lord, Splynncryth, Splynn, Kittani, Powerlord, Metztla, Sunaj, and other names, titles, characters, character likenesses and slogans are trademarks owned by Kevin Siembieda and Palladium Books Inc.

Palladium On-Line: www.palladiumbooks.com

Rifts® Dimension Book™ 8: Naruni™ Wave Two is published by Palladium Books Inc., 12455 Universal Drive, Taylor, MI 48180. Printed in the USA.

Palladium Books® Presents:

Rifts® Dimension Book™ Eight:

Naruni™ Wave 2

A Rifts® and Phase World® sourcebook

Written by: **Carmen Bellaire, Julius Rosenstein & Kevin Siembieda**

Some additional text & ideas by: **Patrick Nowak and Kevin Siembieda.**

Rifts® created by **Kevin Siembieda.** *Phase World®* created by **C.J. Carella.**

Editors: **Alex Marciniszyn**

Wayne Smith

Proofreader: **Julius Rosenstein**

Cover Painting: **Freddie Williams II**

Interior Artists: **Drunken Style Studio (DSS)**

Brandon C. Clark (DSS)

Mark Dudley (DSS)

Mike Majestic (DSS)

Chuck Walton (DSS)

Apollo Okamura

Michael Wilson

Art Direction & Keylining: **Kevin Siembieda**

Typography: **Wayne Smith**

Based on the RPG rules, text, characters,
concepts and Megaverse® created by **Kevin Siembieda.**

Special Thanks to Carmen who went wild creating bunches and bunches of new weapons, armor, robots and material to help continue the legacy of Naruni Enterprises. Also to Julius for more background behind the Naruni empire, Pat Nowak for inspiring me to do this book, the guys at Drunken Style Studio for kicking out some of their best artwork yet, Freddie for a cool Naruni cover, and Paul for just being Paul. A tip of the hat to Wayne, Alex, Hank, Steve, Erick and the all the usual hard working Palladium staffers.

– *Kevin Siembieda, 2004*

Contents

Naruni: Wave Two	6	NE-102 “SpitFire” Mercenary Multi-Rifle	31
Naruni Enterprises Returns	6	NE-103 “Silverfire” Mercenary Multi-Rifle	32
Sales Markets & Client Base	8	NE-104 Missile Mercenary Multi-Rifle	32
Naruni Enemies	9	NE-105 Super-Rail Gun	33
Naruni Ethics	10	NE-700 Vulcan Plasma Cartridge Mini-Gun	34
Naruni Society	11	New! Thermo-Kinetic Armor	35
Board of Directors	11	NE-CS1 Cermalyte Black Nightsuit	36
Guidelines	11	NE-BA-20 “Stalker” Partial Body Armor	37
Naruni Factions	12	NE-BA-26 Special Body Armor	37
Naruni Names	12	NE-BA-30 Light Combat Armor	39
Faction name	12	NE-BA-40 “Infantry” Medium Body Armor	40
Sub-faction name	13	NE-BA-50 “Raider” Heavy Body Armor	40
The personal name	13	NE-BA-55 “Super-Soldier” Exoskeleton	41
Vengeance Volumes	13	Body Armor Accessory Packs	42
Molock Enforcers	14	NE-02S Servo-Harness (Basic)	42
Shulkh	18	NE-05GP Grav Pack	42
Naruni Enterprises Summer Catalog	21	NE-07JP Jet Pack	43
Dear Customer	21	NE-09SP Survival Pack	43
Favorite Back Stock	21	Power Armor & Robots	44
Naruni Firearms	21	NE-EA35 “Earth Angel”	44
Naruni Vehicles	21	NE-AA30 “Space Angel”	47
Other Naruni Items	22	NE-SA40 Stealth Power Armor	49
New NE Weapons	23	NE-1A-TWPA Tech-Warrior Power Armor	51
Ripper Vibro-Blades	23	NE-DXL-07 “Razor” Heavy Power Armor	54
New! Slim-Line Weapons (Plasma Cartridge)	24	NE-PA003 “Drudge” Industrial Power Armor	55
Ammo Warning	24	NE-X4-LH “Sun Chariot” Experimental Power Armor	57
Types of Plasma Cartridges	24	Robots	60
NE-3 Slim-Line “Gambler” Revolver	24	NE-DXZ-09 “Hammer” Super Combat Robot	60
NE-6SL Slim-Line “Magnum” Revolver	25	NE-R2000 “Reaper” Assault Robot	63
NE-8SL Slime “Barrage” Auto-Pistol	25	NE-040 Point Defense Drone	66
NE-202 Slim-Line “Widow-Maker” Pistol	25	NE-A420 Ground Attack Drone Fighter	67
NE-9DB Slim-Line Double-Barreled Shotgun	25	NE-A400 Interceptor Drone	68
NE-11 Slim-Line Plasm Cartridge Rifle	26	Hovercycles & Ground Vehicles	70
NE-80 Slim-Line Lever Action Plasma Rifle	27	NE-RB-660 “Spitfire” Racing Bike	70
NE-295 Slim-Line “Maximum Threat” Assault Rifle	27	NE-HC-120 “Shadow” Combat Hovercycle	72
NE-350 Slim-Line “Thumper” Submachine-Gun	27	NE-HC-109 Combat Bike Nine	74
Other Types of NE Weapons	28	NE-DD6 “Rover” SUV	75
NE-Classic Earth Series Handguns	28	NE-ATRV3 “Pathfinder” All-Terrain RV	76
NE-77H Cyborg Shoulder Cannon	28	Aggressor Mark II Hover Assault IFV	77
NE-78GL Super-Plasma Launcher	29	New Aircraft	79
NE-99 Rapid-Fire Assault Laser	29	NE-J-TA15 “Javelin” Combat Transport Aerodyne	79
NE-97 “Triple Threat” Laser Rifle	30	NE-NS74 “Quad-Wing”	80
NE-101 “Popper” Mercenary Multi-Rifle	31	NE-SDSR-2000 “Star Dragon” Superiority Fighter	83

NE-MD1000 “Wrath of God” Destroyer	85
NE-010 Destructo-Drone	88
NE-020 Combat Drone	89
NE-030 Spy Drone	89
Land Mines	90
AIM-1 Anti-Personnel Mine	90
NE-MAT-3 Anti-Matter Anti-Tank Mine	90
NE-APM Anti-Personnel Mobile Mine	90
Smart Bombs & Mobile Mines	91
Thunderstorm Mobile Land Mines (MLM)	91
NE-TA03 “Streaker” Thunderstorm MLM	91
NE-TH05 “Land Skimmer” Thunderstorm MLM	92
NE-TT07 “Sneaker” Thunderstorm MLM	93
NE-TU09 “Swimmer” Thunderstorm MLM	93
NE-AP/ATM-5 “Crawler” Walking MLM	94
K-HEX Explosives	95
K-HEX Plastique Cubes	95
NE-10G Grenades	95
NE-20G Micro-Grenades	95
Explore the Palladium Megaverse®	96

Quick Find

Aircraft	79
Body Armor	35
Drone: Ground Attack Drone Fighter	67
Drone: Interceptor (aircraft)	68
Drone: Others (old style; see Wrath of God Destroyer)	88
Drone: Point Defense	66
Catalog of Naruni Weapons (starts)	21
Earth Guns (look-alike; see Classic Earth Series)	28
Energy Weapons (start)	28
Enforcer: Molock	14
Experimental Power Armor (see Sun Chariot)	57
Flying Knight Power Armor (see Earth Angel)	44
Hovercycles	70
MLM (see Mobile Land Mines)	91
Naruni Lead Salesman on Earth (see Shulkh)	18
Naruni’s Plans for Rifts Earth (Sales Market)	8
“The” Naruni Faction	8
Plasma Cartridge Weapons	24
Power Armor	44
Robots	60
Robot Drones	66 & 88
Shulkh Tvarnik Quornall (see Shulkh)	18
Vibro-Blades	23

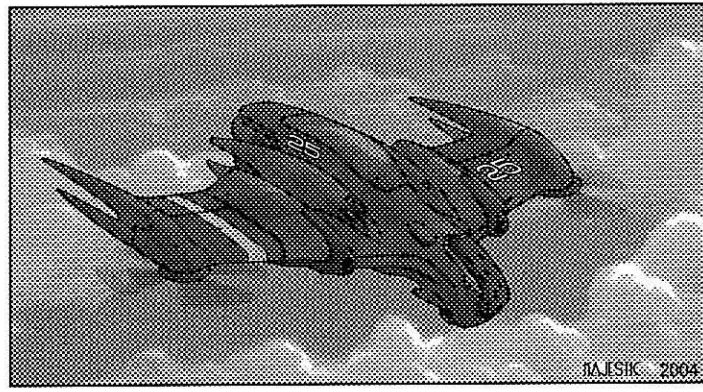

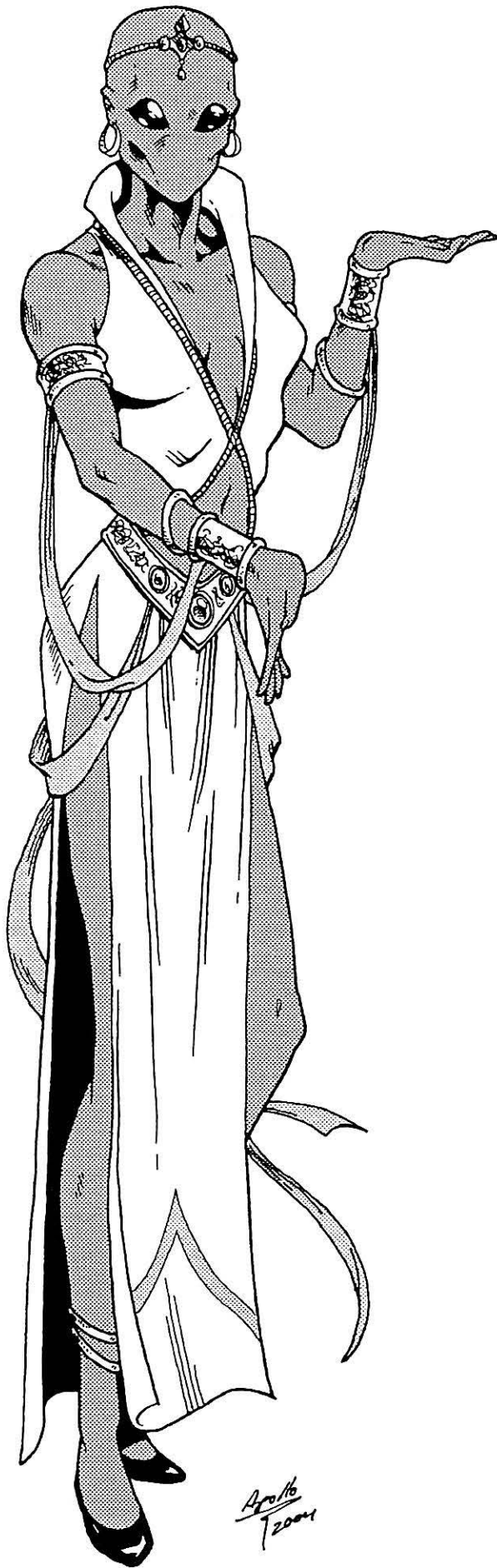

Naruni: Wave Two

The idea and title for this book were inspired by material included in Patrick Nowak's manuscript for his upcoming **Rifts® Mercetown** sourcebook (a companion to *Rifts® Mercenaries One*). I enlisted the imaginations of Julius Rosenstein and Carmen Bellaire to help fill in Naruni activities, people and equipment, while I tweaked the text, did the intro section and added the bits and pieces needed to make it all fit together smoothly.

The end result: A catalog of new high-tech weapons and equipment, the return of a favorite antagonist in the Naruni, and countless new avenues of adventure and conflict.

We hope you enjoy the setting, conflict and equipment as much as we enjoyed putting it all together.

– Kevin Siembieda, 2004

Naruni Enterprises Returns

By Julius Rosenstein & Kevin Siembieda

As one of the largest (if not 'the' largest) arms dealers in the Three Galaxies (and then some), the Naruni often outfit entire planets. Compared to this, arming individual kingdoms, even their larger orders (such as to Los Alamo and the late, lamented Tolkeen), is tantamount to pocket change. Despite this, Rifts Earth has a potential that is far more important than the actual sales the Naruni are currently making. This planet is a gateway with Rifts leading to thousands of other worlds and dimensions. Even the Naruni themselves are not sure how many more new markets they can acquire through the proper exploitation of the gateways on Rifts Earth. At any rate, the thought of obtaining many of these untapped sales territories is enough to make any Naruni lick their tentacles in anticipation. However, Naruni Enterprises' initial foray into the Earth market met with disaster.

By 105 P.A., Naruni Enterprises had managed to establish itself as a premier dealer in high quality weapons only a few years after it appeared on Rifts Earth. Its reputation for superior high-tech weaponry, body armor, combat vehicles, and force field technology spread like wildfire. The corporation had only begun to garner a large number of clients, especially among mercenary groups and the lesser kingdoms scattered across the North American continent, when they were struck down by treachery. The company's success had quickly supplanted the sales of local arms manufacturers like *Northern Gun*, *Manistique Imperium*, *Wellington Industries*, *Wilk's* and the *Black Market*, making them and Naruni Enterprises instant rivals. Lacking the technology to compete with the Naruni, all desperately sought to eliminate the alien interlopers from the open market. The ultimate solution chosen by *Northern Gun* of Ishpeming and the *Manistique Imperium* was an alliance with the Coalition States and helping the CS to find NE sales reps and stockpiles and destroy them. The CS had already branded Naruni weaponry as subversive alien technology, and the united

campaign to hunt down and destroy Naruni Enterprises' holdings in North America was a quick and resounding success thanks to the help of its two new allies. The Black Market, Wellington and others also secretly worked to undermine Naruni Enterprises by working behind the scenes and feeding Northern Gun and the CS information to help them locate and destroy NE inventory, base camps and sales reps. The paranoid Coalition States, who had already identified the Naruni presence as a dangerous alien threat, conducted their campaign against Naruni Enterprises with savage efficiency.

The sudden, violent campaign caught agents of the Naruni by surprise. Its trading posts were sabotaged and destroyed, its sales representatives slaughtered by CS forces, and thousands of NE *clients/purchasers* were summarily executed for even possessing Naruni technology. Where the CS failed, Northern Gun and the other rival weapons dealers succeeded. The rivals gladly paid informers, and the CS offered a handsome reward for the head of every Naruni agent killed and brought to them, as well as a bounty on every NE weapon or piece of gear turned over to them. Approximately 254 agents of Naruni Enterprises were "brought to justice" in the fall of 105 P.A. It mattered not to the Coalition that there were only 32 actual Naruni sales reps working on the continent. The rest were poor slob who happened to possess two or more Naruni weapons or equipment (or other alien looking technology) and were declared dealers, killed, and their bodies and alien gear turned in for a reward. All traces of Naruni Enterprises were eradicated from the face of continent in less than a year, marking the opening salvo of the *Coalition Campaign of Unity*, though in the aftermath of the war, and subsequent fall of Tolkeen, that chapter in history is all but forgotten, at least by most. After all, the average human and D-Bee has never even heard of Naruni Enterprises, only mercenaries, outlaws and adventurers know of the Naruni.

To this day, Naruni weapons and equipment are outlawed in and around the Coalition States (even non-combat items). Those caught by the CS carrying NE gear are gunned down where they stand – all in the name of national security. Things have been especially hot since the fall of Tolkeen and the return of Naruni Enterprises. Characters who dare to use Naruni Enterprises' weapons, vehicles, armor or equipment should do so with extreme caution, for the CS regard them as dangerous subversives and enemies of humankind for embracing alien technology. It also gives the CS carte blanche to gun down any dissident, crook or suspect caught using NE gear. This, in turn, has fueled injustice and cruelty at the hands of the most vicious Coalition soldiers. Most (70%) Coalition soldiers dutifully destroy Naruni items on the spot, the rest turn items over to their superiors (30%). NONE even consider using *alien* technology.

When Naruni Enterprises were effectively kicked off the planet by Coalition forces, the Board of Directors at corporate headquarters in the Three Galaxies were outraged. Nobody hands Naruni Enterprises their inventory and sends them packing. Nobody. Especially not some human empire like the Coalition States on some backwater trans-dimensional crossroads. However, Rifts Earth was a special case, and the Naruni had to be careful. Far too many dimensional powers such as the Splugorth, True Atlanteans, various gods, dragons and others (many more than people realize), had taken a keen interest in keeping Rifts Earth an *open and free travel zone* unclaimed by

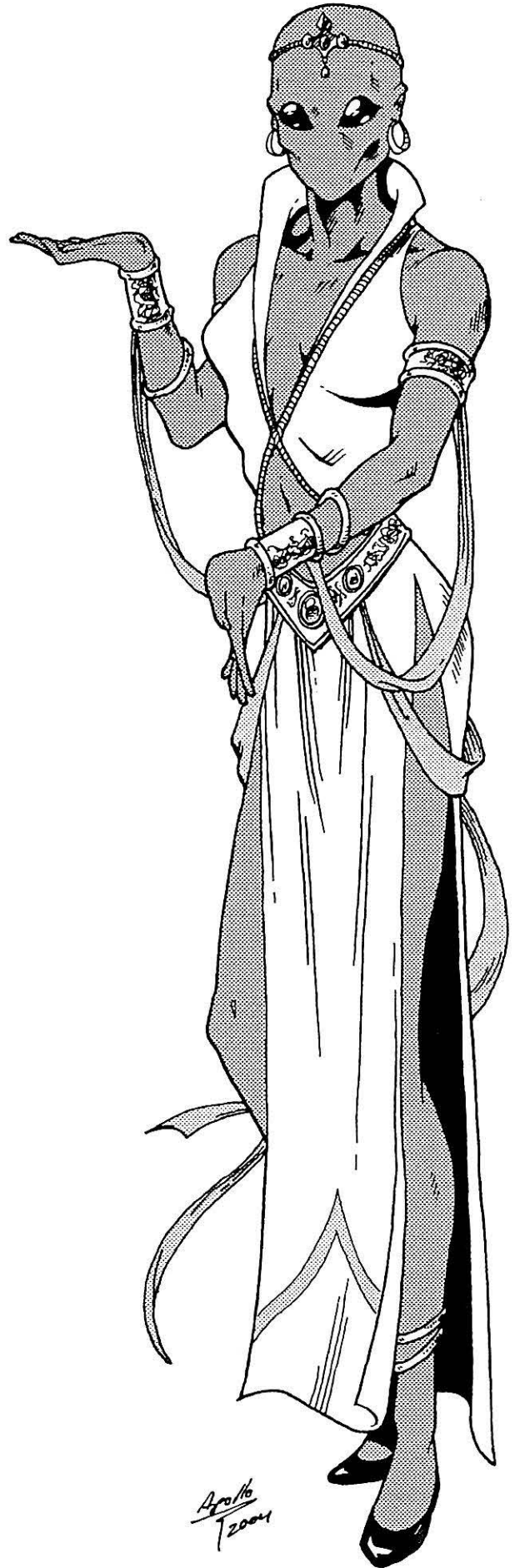

any of the dimensional superpowers. This meant powerful forces frowned on Naruni Enterprises exacting revenge on the Coalition by backing the Tolkeen forces and providing them with weapons of mass destruction at discount prices. The powers that be, including the Naruni Board of Directors, wanted to maintain the status quo. As a result, the offended faction within the Naruni trans-dimensional mega-corporation was told to back off and refrain from retribution. After all, Naruni Enterprises had informally agreed with the other trans-dimensional powers that no single group would try to conquer or subvert the people of Rifts Earth. Toppling the CS would be an act of outside intervention changing the status quo and making people uncomfortable with the Naruni's direct involvement. This forced the offended party within Naruni Enterprises to accept their losses (and more importantly, their humiliation) without retaliation. Based on the recommendations of its *Social Studies Branch*, the NE corporation decided to step back and forget about marketing products to the people of Rifts Earth. The ousted Naruni faction within the company protested, but was ordered to comply. A cooling off period of several years was recommended before the corporation would allow anyone to consider turning their attention back to the planet.

Ironically, Rifts Earth holds little value as a venue to market Naruni equipment, at least compared to Naruni Enterprises' many other holdings and operations, so in the grand scheme of things, the incident is barely a blip on the radar screen. Consequently, all but one faction within Naruni Enterprises have chosen to pursue much greener pastures and forget about Rifts Earth. The one faction who can't let things go is the laughing stock who had their butts handed to them by the CS and ousted from Earth. For them, redemption of their reputation demands a return to Rifts Earth. The Splugorth – ancient rivals of NE – have rubbed salt in the wounds of the ousted faction by sending them messages suggesting that the people and politics of Rifts Earth are too complicated for them to handle, and that they should cut their losses entirely and turn their attention to other worlds, or hire a Splugorth representative to help them. To the Naruni faction kicked off Earth, this is an insult and a challenge. One they intend to meet.

In classic fashion, the returning Naruni faction is playing one side against the other by offering the enemies of the Coalition States NE weapons at bargain-basement prices. (Bear in mind that a 10% to 20% discount below list price *is* as bargain-basement as the greedy Naruni get. Naruni usually milk those consumed with a lust for revenge by overcharging them, but this time it's personal, and the Naruni faction on Earth is pulling out all the stops.)

The Naruni faction has learned from their last ill-fated escape, and are being much more clever about their operations in the Coalition's backyard. Naruni sales reps and agents are constantly on the move, inventory stockpiles are constantly relocated, Naruni (Uteni, really) are using humans and D-Bees to front for them as sales reps, and the Naruni agents don't trust anyone!

Rumor has it that Naruni Enterprises' central base for North American operations is located somewhere in the shattered Kingdom of Tolkeen, right under the nose of the Coalition Army. If the rumor is true (and it may not be), the company is probably using one or more of the Minnesota ley lines and/or

nexus points as a means of dimensionally transporting merchandise and personnel from one secure location to another. Rumor also has it that Naruni Enterprises has built a sales headquarters, complete with showroom, weapons, power armor, vehicle dealership, high-tech augmentation clinic (for NE cybernetics & bionics), and bionics repair facility located in the old war zone of Minnesota or Wisconsin. To make matters worse for the Coalition States (who is only just realizing NE is back with a vengeance), Naruni Enterprises is offering a line of energy weapons that appear to be ordinary S.D.C. pistols, revolvers, and shotguns. For the first time ever, this NE faction is putting fun (i.e., a wicked but playful kind of revenge) in front of profits. Of course, as always, the Naruni (and Uteni) involved only have their own agenda at heart, so while they may claim to champion some cause or nation, their clients are just a means to an end – in this case, a little fun revenge and a little profit on the side.

Sales Markets & Client Base

Since arriving on Rifts Earth, the vengeful Naruni faction has made some significant inroads in establishing their sales territories. Thus far, most of their sales have been restricted to clients in Midwestern America. *Tolkeen Freedom Fighters* are the Naruni's primary market targets, with *Retribution Squads* close behind them. Meanwhile, Naruni sales reps are approaching independent kingdoms, mercenary companies, and splinter factions from the Federation of Magic, along with other groups active in harassing and undermining the CS in Minnesota, Wisconsin, Illinois and the Chi-Town 'Burbs, with NE weapons, vehicles and gear. Current sales are enough to whet the appetites of potential clients, and enough to give the Coalition States trouble, but they are not enough to seriously threaten the CS or its government. Even this, however, has worked the Coalition authorities into a frenzy and troubles the other arms dealers. While Naruni Enterprises are currently focused on the Tolkeen/Chi-Town front, it seems only a matter of time before they begin to offer weapons to the lawless bandits of the Pecos Empire, the Juicer horde of Julian the First, Native Americans, Brodkil, and other enemies of Chi-Town! The Coalition government and its arms dealing allies must constantly wonder what Naruni Enterprises has up its sleeve next, and when the aliens might accelerate their activities into promoting all-out war. That is, after all, the standard Naruni modus operandi. Isn't it? The Naruni don't usually digress from standard operating procedures, do they? What's next? What terrible plot of insurrection are the Naruni pandering to? What causes are they working to inflame? Who are they supporting? Why? And when will they strike? These are exactly the kind of questions, concerns and uncertainty Wave Two is supposed to elicit, and the Naruni on Rifts Earth are quite pleased with themselves. Ultimately, the Naruni's Wave Two has nothing to do with war or insurrection, it is designed to be a pain in the neck, harassing, frustrating and thumbing their nose at the Coalition States and their allies, Northern Gun and the Manistique Imperium, as well as the others who worked against them in the past.

1. Tolkeen Freedom Fighters. During the Siege on Tolkeen, all attempts to communicate with Naruni Enterprises seemed to fail (ordered to stay out of the conflict by the Board of Directors). Since the fall of the magic kingdom, the alien arms dealers

have reappeared and seemed to offer a second chance for those willing to take it: Advanced weapons at discount prices (10-20% below the list price). Ostensibly, the Naruni's excuse is that they want to help avenge a fallen client. Although this is partially true, a significant payment has already been made on many of these weapons by the late Tolkeen government and pocketed by the Naruni. Somehow, the Naruni reps keep forgetting to mention this fact when they are re-negotiating prices and terms with the Tolkeen resistance groups. The returning Naruni find it easy to prey on the hate, anger and lust for retribution shared by Tolkeenites who seek to restore the Kingdom of Tolkeen or desire to exact bloody revenge against the Coalition States.

2. Tolkeen Retribution Squads: The fanatical Retribution Squads are the next most favored clients of the returning faction from Naruni Enterprises. They too are being supplied with weapons at cut rates (10-20% off list price).

3. Brodkil Gangs: The leaders of Tolkeen had amassed legions of unholy warriors and allies, the tech-hungry sub-demons known as the Brodkil among them. Since then, the Brodkil have scattered into small bands of raiders, reavers, mercenaries for hire, and gangs out for Coalition blood. The CS Occupation Force has been especially rough on Brodkil gangs, creating a lasting hate between them and the monsters. Brodkil are particularly fond of bionics and all kinds of energy weapons.

4. Mercenary Companies: There are a number of merc companies who employ Naruni weapons. Currently, the biggest customer is Robot Control (**Rifts® Mercenaries One**, pages 67-77). However, several others are being courted, including various bands of Juicers and Crazies, and Julian the First, in particular. Discounts may or may not be offered depending on the group the Naruni are dealing with (typically 5-10% discount off list price).

5. Adventurers: The fall of Tolkeen has created an environment that has brought countless adventurers, bounty hunters and warriors to the region. All are considered potential clients. No steep discounts (5% if any).

6. Outlying Independent Communities: The collapse of Tolkeen has signaled a new age of Coalition Imperialism and expansion, or so many fear. As a result, Naruni Enterprises has approached many small kingdoms and communities with weapons and equipment that should contribute greatly to their defense (5-10% discount).

7. Dissidents and Insurrectionists: Any enemy of the Coalition States is a potential client of Naruni Enterprises. These are favored clients who may be offered discounts of 5-20%.

8. Federation of Magic Factions: Though Naruni Enterprises has made no attempt to contact Lord Dunscon or his Federation of Magic, they are willing to sell to anyone who hates the CS, including smaller subsets of the Federation of Magic and individual mages. Naruni force fields are coveted by practitioners of magic, who can't normally wear metal or heavy armor. Discounts are rare and seldom more than 5%, if at all.

9. People of the Chi-Town 'Burbs: Naruni Enterprises has infiltrated the Chi-Town 'Burbs where they sell a variety of weapons, armor, force fields and gear suitable for an urban environment. Their influence in the 'Burbs is the weakest of anywhere, because of the iron grip the CS has on the 'Burbs and because the Black Market, Northern Gun and other weapons

dealers are well established in the community with friends, spies and paid informers everywhere. So far, Naruni sales reps use hit and run sales tactics in the 'Burbs, appearing out of the blue to make a few sales and vanishing for weeks or months at a time. Presumably, NE has no permanent agent or base within the 'Burbs. Discounts range from 5-15%.

10. Los Alamo: If there was any place that could have been considered "Naruni Central" in the past, this was it. When the NE trading delegation first came to Los Alamo in 104 P.A., this Texas nation quickly became the Naruni's biggest client. The Naruni Trading Depot established there was the largest and most well-stocked outlet of Naruni-made weapons. With an estimated sales of over 150 million credits in the first year, the Naruni are expected to return to Los Alamo and re-establish this beachhead front . . . but will they? The Coalition and their rivals know about their past affiliation and will be wanting them to reappear at Los Alamo so they can pounce.

Note: Naruni Enterprises has never tried selling weapons anywhere on Earth but North America.

Naruni Enemies

For their long-term plans, Naruni Enterprises will have three main obstacles (or adversaries) to deal with: the Coalition States, the native weapons dealers (Northern Gun, Manistique Imperium, Wellington Industries, and others) who don't want them intruding on their sales turf, and the Splugorth of Atlantis.

The Coalition States are the most immediate and dangerous threat, though one should never underestimate the competitive heat of the other arms dealers. The CS have been rabidly anti-Naruni since the first encounter between the two. Not only are Coalition authorities willing to kill Naruni on sight, they are putting pressure on everyone else to do so as well. Los Alamo refused in the past and has been on the CS Enemies List ever since. The CS is ramping up its anti-Naruni countermeasures and cracking down on anyone caught with NE weapons and equipment. Brutality and intimidation continue to be part of the Coalition's arsenal against the Naruni and all who oppose the will of their nation.

NE is now offering better rates and terms to anyone who looks willing to use their weapons against the Coalition. However, despite the personal satisfaction they might feel from the CS suffering a major defeat, the Naruni are careful not to support the Coalition's enemies to the point of overkill.

Weapon manufacturing rivals have reason to worry. The Naruni haven't forgotten the treachery of the weapons manufacturers, and though the Naruni admire their rivals' decisive and deft business decision to eliminate them as a competitor, the Naruni plan to hit them where it hurts most, the wallet. The weapon dealers know competition is about to get ugly and plan to renew their efforts at eliminating this second wave of Naruni profiteers as quickly as they did before. Only this time, the alien merchants are prepared, and the rivalry, sabotage, backstabbing, and finger-pointing is about to get crazy.

The Splugorth find this new course of action annoying and disturbing. They too work to undermine the new wave of Naruni sales reps whenever they can. This is done by alerting the CS and rivals to Naruni activity and invisibly causing trouble for

the Naruni by whatever covert means available. Even though the Splugorth have taken a more laid-back position for the present (as opposed to the virulent anti-Naruni attitude of the CS), the Naruni realize how formidable the Splugorth can be. With the firepower and resources that Lord Splynncryth and his minions can bring to bear, an aroused Atlantis can make the most rabid efforts of the CS seem like a minor annoyance in comparison.

The Naruni may be the only ones on Rifts Earth who realize the full power of the Splugorth. So, they are indirectly trying to manipulate things so that the Coalition will ultimately be forced to act as a buffer against the Splugorth. **Note:** If the Splugorth have been entertaining the idea of expanding into North America, as many suspect, the return of the Naruni (who will tattle on them) may stop that effort cold in its tracks.

Game Master Note: Naruni Enterprises is definitely using more caution in their operations than during their first, brief visit to Earth. With their secret factory/military base of operations, the trans-dimensional company has a strong foothold on the continent and is likely to cause trouble for years to come. The company is entirely too optimistic when it comes to the opposition they are bound to face. Naruni Enterprises has completely underestimated the Coalition's willingness and ability to wage extended military campaigns against those they regard as an alien threat. The Coalition's xenophobic paranoia makes them even more ruthless and relentless than usual, and the Coalition Army will not rest until Naruni Enterprises and every last one of their weapons are wiped from the face of the Earth. The CS will find this task far more difficult than it was the first time but it is an attainable goal. Furthermore, the extreme measure of killing anyone caught with a Naruni Enterprises product is a welcomed opportunity for the most aggressive, hateful and xenophobic among the CS troops, and an excuse to engage in wholesale massacres against practitioners of magic, D-Bees, and outsiders.

Naruni Ethics

Working for the Naruni is often a grueling and thankless task. The Naruni are demanding bosses who try to wring the last ounce of labor out of their employees. Some Naruni operations are slavery in all but name – long hours, minimal wages, barely subsistence working conditions, brutal productivity levels, and harsh penalties for failure. Yet, despite this, working for the Naruni is far from the death sentence many believe it to be, and many a sales rep has earned a fortune in his lifetime.

Most Naruni and Uteni Shifters are only concerned about the efficiency of their operations and do not care about their workers beyond what is necessary to keep them productive. If it is required, Naruni will make the effort to create the proper environment needed to get the job done in the most efficient manner.

However, when this occurs, the Naruni generally make it clear that better conditions for their workers is to be regarded as a "privilege" and not an inalienable right. When the Naruni spend valuable time and resources to improve the lot for their employees, the employees had better respond with increased productivity. Failure to do so will result in the privileges (i.e. the improved conditions) being revoked.

The Naruni are ruthless and stern, but not sadistic or heartless. Unlike other races (such as the Splugorth) who will torture and/or kill just for pleasure, Naruni generally find such activities

to be an inefficient waste of energy and potential resources. Although the Naruni and their Uteni agents are capable of torturing or killing (if they feel that the situation warrants it), its use is entirely done for pragmatic reasons, not personal revenge or pleasure. These reasons include (but are not limited to): uncovering industrial spies and saboteurs, inspiring their workers to better efforts, and ridding themselves of troublemakers by setting an example to the other workers (i.e., behave or else). At any rate, when Naruni utilize torture and/or murder as a punishment, it is usually with the goal to increase productivity or preserve/protect the company. They seldom kill for emotional reasons.

The Naruni and their right-hand accomplices, the Uteni, can be severe taskmasters and may work their labor force to the point of exhaustion, but seldom to the point of death. Naruni invented the idea of sweatshops long before the human's ancestors climbed out of the trees. Unions are unheard of, and people, especially conquered people and indentured servants (those who could not pay their bills), are worked like mules.

There are three things about laboring for the Naruni that are often surprising to many outside observers.

The first is that the death count of Naruni employees is much lower than what many would expect. To the Naruni, workers, even slave laborers, are a valuable asset. Though the Naruni do not really care about the comfort of their workers, per se, they understand the value of incentives and having a motivated and happy, workforce. Thus, they generally make the effort to ensure the safety and protection of their workers as well as providing bonuses, sick days (at half pay), vacations and other perks

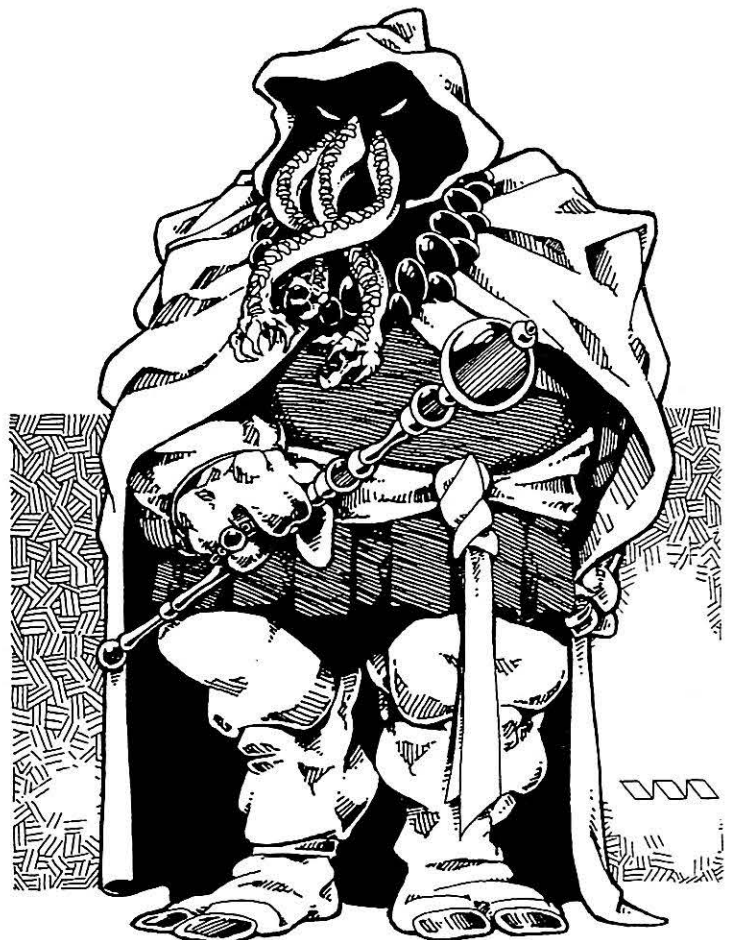

for those who prove to be the best workers. Granted, there are occasions when the Naruni will consider their labor force expendable, but more often than not, the Naruni try to preserve their workforce.

The second is that the working conditions are often better than might be expected. The Naruni learned long ago that contented workers, a clean workplace and cutting-edge technology significantly increase productivity. Consequently, most Naruni factories and workplaces are clean, well lit, and brimming with the most efficient machinery for the task at hand. Since "the company" provides almost everything for its workers, the Naruni provide a wide range of good to outstanding quality food, excellent working conditions, health benefits and other amenities uncommon in most workplaces.

Finally, masters of the carrot-and-stick method of motivation, some of the Naruni bosses will reward workers who do an exceptional job. The Naruni are not particularly fair bosses or equal opportunity employers, but they do recognize the value of workers who demonstrate loyalty and, especially, blind obedience. Such workers can expect cash bonuses, special foods and treats, better creature comforts like improved living quarters, discounts on products, and so on. Sometimes, a particularly talented worker may actually get promoted and move up the corporate ladder. However, this occurs much less frequently and it should be noted that most *titles* other than "boss," "manager," "sales rep," "enforcer," "Board of Directors," "Social Studies Branch," and "Naruni" (always a boss in the upper echelon) are typically meaningless and without authority, pay raises or true power attached to them.

True Naruni believe themselves to be superior to most other races. However, they do accept the concept that even inferior races sometimes have individuals who are exceptional. Some of these individuals are talented enough to be deemed worthy of management and sales positions at Naruni Enterprises. For the most part, the NE leadership consists of *True Naruni* with a large contingent of Uteni aliens in management and sales positions. The Uteni are effectively the second tier of management and elite workers who answer directly to the True Naruni. However, the ever pragmatic Naruni have shown themselves to be surprisingly liberal in promoting members of the so-called "inferior races" who have demonstrated a talent for their jobs. These privileged employees are then used by the Naruni as examples to their fellow workers as what they can expect from loyalty and hard work.

Naruni Society

Naruni society is very reminiscent of a mega-corporation where all the executives are continually jockeying for higher positions and pay. Although the competition is cutthroat and some Naruni will attempt to permanently rid themselves of their rivals, there is greater prestige in foiling a rival's efforts and ruining one's rival financially. Most Naruni and Uteni find this to be both civilized and infinitely more satisfying than outright destruction or murder.

Naruni often seek to better their own position by outmaneuvering and bankrupting their rivals. After defeating their rivals in this manner, a common practice among the Naruni (and the Uteni who serve them) is to then hire these ex-rivals and put them to work in lesser positions.

Despite the loss of prestige and status this entails, most Naruni and Uteni who fall victim to a rival's cunning and duplicity do not take it personally nor seek vengeance against their adversary turned employer, beyond the desire to improve their fortunes and ultimately turn the tables on their foe and bankrupt them in turn.

Although Naruni are commonly judged by their success and accumulated wealth, poverty does not carry a permanent stigma. The volatile nature of Naruni commerce and rivalry is such that the average Naruni will make and lose several fortunes during the course of their lifetime. Thus, a Naruni who is bankrupt is seen as an individual on the cusp of a new business venture.

The penultimate free enterprise system, Naruni are given a great deal of leeway to pursue their business ventures. If they are successful, they are generally left alone as long as they continue to make a profit for the Megaverse spanning mega-corp, *Naruni Enterprises*. Failed business ventures can result in the Naruni being demoted to a lesser position and having to claw their way back up the corporate ladder. However, the **Naruni Board of Directors** has established guidelines as to certain business practices to which all must adhere. Many races who have gotten the short end of the stick in dealing with the Naruni would be astonished to learn that the company actually does have a code of business ethics. However, no one would be surprised to learn that this code primarily benefits the Naruni and free enterprise.

Since all of the Naruni know that crossing the Board of Directors is tantamount to a death sentence, these guidelines are carefully observed. Some of the more successful Naruni have learned how to effectively bend the rules to their advantage, but no one will actually break them.

These guidelines are generally based on pragmatism mixed with avarice. Among the most common guidelines are:

1. Naruni Enterprises relies on its reputation and image throughout the Megaverse. Although individual Naruni may be made to look incompetent or foolish, the reputation and image of the corporation is never compromised.

2. Although the Naruni readily use members of other races as pawns in their schemes, they may not be allowed to employ them in a manner that will cause these races to consider themselves as peers of the Naruni or even the Uteni.

3. When other Naruni are bankrupted and then hired, there is a certain level of decorum and courtesy that must be maintained. Certain tasks are beneath the dignity of a True Naruni and one should never be asked to perform them. For example, rival Naruni may be given extremely low-level management positions with little power or authority and the worst assignments, but they are never to be forced to work on the assembly line, put to work as janitors, or made to do any other type of menial labor.

4. Killing a True Naruni is a crime to be avoided at all costs. Murder sets a dangerous precedent, creates discord, reduces productivity, and puts the elevated Naruni on the same level as the lesser creatures who work under them. Murder among the lesser labor force at their own hands is a necessary evil that should be discouraged but expected. True Naruni should, however, avoid soiling their hands with the blood of the labor force, and try to find peaceful and productive solutions to discord among the rank and file. Should such solutions require murder, the task

should be delegated to managers and enforcers and never delivered by a True Naruni directly.

5. Dealing with the Splugorth should be avoided at all costs, unless it involves a chance to damage their reputation or acquire (steal) their resources (preferably without getting caught).

Naruni Factions

Officially, Naruni Enterprises is the law of Naruni society. NE arbitrates disputes and keeps the peace (more or less) throughout the Naruni sphere of influence, preventing widespread bloodshed (i.e., more than what is deemed acceptable or necessary) between the non-Naruni members of their empire.

Semi-officially, the Naruni are split into a myriad of smaller factions. True Naruni know that an individual alone is far weaker and more vulnerable than someone with friends and allies. Factions are formed when Naruni get together to assist or protect one another. There are thousands of factions throughout Naruni Enterprises and they cover a wide range of different areas of commerce. Some factions are very expansive and will accept any Naruni interested in joining their group, while others are very exclusive as to whom they will allow into the fold.

Some factions are very loose-knit while others are clan- or cult-like and try to establish ironclad bonds between their members. Membership in a faction may range from tens of thousands to family clans and individuals looking for a business fellowship, support or mutual benefit.

Factions may be based on common interests, similar outlooks on life, shared goals, related or shared business enterprises, or practically any other reasons that two or more Naruni may find for joining forces for their mutual benefit and profit sharing. In many cases, the faction itself is based upon some broad premise such as expansion into the Corkscrew Galaxy, mining a particular planet, solar system or asteroid belt, or opposition to the United Worlds of Warlock or other rival or enemy, and any other cause or business opportunity the Naruni may find advantageous to pursue. Members with different views toward other things may form smaller or sub-factions within the larger faction. Two common denominators of factions are: **One**, the Naruni joining the faction are interested in gaining support of some type; and **two**, shared risk and shared profit. **Note:** Only True Naruni are allowed to pick, create and join business factions. Uteni, Molock Enforcers and the labor force are all employees of the faction or Naruni business partners.

The factions do not receive any official recognition from Naruni Enterprises. Unofficially, however, they are often the motivating factor for new business ventures and a force that cannot be ignored. Factions with a large enough membership or with members placed in strategic positions, frequently spell the difference between the success or failure of many a business operation.

Rivalries between factions are intense, and they all attempt to assist and promote their own members, causes, and business pursuits over others. Of course, faction members who aid other Naruni or enlist a new Naruni into their faction expect some type of reciprocity (favor for favor) or mutual reward (the bigger the better). In a cutthroat business environment like Naruni Enterprises, where everyone constantly has to watch their competition, having someone to watch their back (for whatever rea-

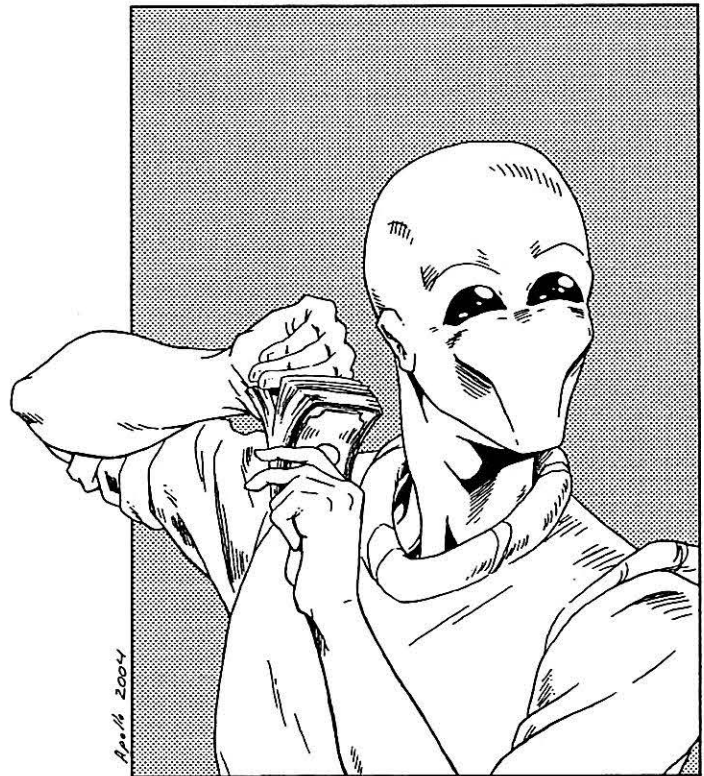

son) is of great value and may be the difference between success and failure.

Although started by True Naruni, Naruni Enterprises does have executives of other races (particularly Uteni). Case in point, the Naruni Enterprises Board of Directors includes a large number of True Naruni, but there are also Uteni, a Godling, a Demon Lord, an Alien Intelligence, and members of some other races. However, there has never been a recorded case of anyone other than a True Naruni holding the top positions of power and leadership within a faction.

Naruni Names

The Naruni use their names not just as means of identification, but also as a means of declaring their allegiance and proclaiming their status. At any given time, a True Naruni has three names. They are (in order): their faction name, their sub-faction name, and their personal name. Although most of them are willing to do everything possible to enhance their personal status, in Naruni society, the individual is less important than the corporation.

The faction name indicates not only who that particular Naruni is affiliated with but also, to some degree, their politics and outlook on life. Some factions are known for being conservative while others are risk takers, some factions are very expansive toward other races while other factions are known xenophobes. Like the old saying about “birds of a feather flock together,” just being connected with a given faction can be a good indicator of that particular Naruni.

A faction name is always important. Even Naruni who, for some reason, are independent of factional ties (extremely rare, but it happens) will create a faction name, sometimes becoming a “faction of one.” Most Naruni in this situation will either try to join an existing faction or recruit others to their (new) faction.

A **sub-faction name** helps indicate their status within the faction. Also, if that particular faction has a number of contrasting groups (not all Naruni factions share a uniform agreement in their views), the sub-faction name further delineates the Naruni as to his specific attitudes (as opposed to the faction name which is more general). Oddly, many Naruni will use their family name as their sub-faction name. However, to a True Naruni, blood kinship and genetic relationships are far less important than business connections.

The **personal name** is last, and, to Naruni society (if not to the individual involved), the least important. Generally, the only ones who use personal names are other True Naruni. Except on formal occasions, everyone else uses the Naruni's faction name (the Naruni encourage this). As an example, Shulkh Tvarnik Quornall (the new manager of Naruni Enterprises on Rifts Earth) is actually Quornall of the Tvarnik sub-faction of the larger Shulkh faction.

Further complicating matters is that True Naruni can change their names frequently. This especially occurs when they change factions (willingly or not). Naruni who change factions but remain on good terms with their former faction may opt to maintain their sub-faction name. Those who leave in disgrace or with hard feelings, however, may find their name has been rescinded by the faction.

At formal occasions, True Naruni are addressed by all three of their (current) names. For normal, day-to-day business, the faction name is used. An honorific title or name may be added, but is not usually required as the faction name itself implies garnered respect. Some Naruni, however, insist on honorific titles when dealing with their subordinates or people outside their sphere of influence. As an example, Shulkh may be addressed (depending upon the specific culture) as Mr. Shulkh, Shulkh San, Senor Shulkh, or just Shulkh.

Addressing a True Naruni by their personal name is a sign of *equality*. Although the Naruni may call one another by their personal names, they regard lesser beings doing so as either an insult or a display of ignorance. New members of the Naruni labor force quickly learn the proper etiquette in addressing their bosses.

There are a number of reasons why Naruni may change their name. These include changing factions, distancing oneself from a previous business failure, avoiding unwanted attention (having a "bad reputation"), attempting to make one's self scarce, trying to drum up new business opportunities, to confuse (or hide from) rivals or enemies, and so on. In a volatile business environment like Naruni Enterprises, it is not uncommon for a Naruni to change their name dozens (or scores) of times over their lifetime.

When a Naruni changes his name, he is not simply taking on an alias. The name change is recognized by Naruni Enterprises as being legal and binding. A Naruni who changes his name, but does not go through the *official process*, forfeits certain legal rights. Under the law of Naruni Enterprises, they still have basic rights and are generally better off than non-Naruni, but they are at a disadvantage when dealing with other True Naruni.

It is easy for a Naruni to change his name. All one needs to do is register his new name with the NE Records Department (a division of the *Social Studies Branch*). The Records Department

does have the authority to refuse the name change but that authority is seldom used.

There is a fee (ostensibly for administration and processing), but it is usually reasonable. If special circumstances are involved, such as changing one's name to that of an existing rival to cash in on their reputation, the fees are dramatically increased, but legal. **Note:** One of the few times that the Records Dept. will refuse a name change is if the applicant's new prospective name is too similar to that of a member of the NE Board of Directors.

True Naruni are granted a fair amount of leeway in what names they choose, subject to the factions, but must keep the Records Dept. updated on any changes they make. Failure to do so results in penalties such as assessed fines, loss of status, etc., in addition to the loss of many legal rights and property.

Once changed, the names are a matter of public record. Anyone, either Naruni or non-Naruni, can contact the Records Dept. and check on the individual involved, however, the fees for non-Naruni are 100 times higher than they are for True Naruni. Also, the Records Dept. will charge separately for tracking each name change. Thus, if a Naruni has changed his name six times, anyone attempting to find out *all* the identities would have to pay six times the normal tracking fee. The NE does not generally care how often their people change their names just as long as they get their piece of the action.

Vengeance Volumes

Naruni are motivated by profit, and even the most vengeful Naruni will often defer their intended revenge against an enemy if they see an opportunity to somehow utilize the situation to make a profit for themselves. That having been said, Naruni have memories like the proverbial elephant, and anyone who crosses one will not be forgotten. Naruni are conscientious when it comes to keeping track of whomever interfered, hurt, bested or opposed them in some way. Practically every Naruni keeps what they refer to as *Vengeance Volumes*.

Vengeance Volumes are books dedicated to nothing except lists of the Naruni's rivals and enemies, and what they are up to. These are generally enemies who the Naruni believes can be ruined, manipulated, tricked, cheated, or otherwise taken advantage of. Although each Naruni may have different criteria as to what warrants a person's entry into their book, standard offenses include insulting the Naruni, causing them to lose money (or status), tricking them out of money or a valuable resource (actually tricking and getting the best of them in any way), damaging their business or reputation, getting the upper hand over them, or interfering with the Naruni's business or plans.

Once the offender is entered into the book, he is kept under some degree of surveillance (how much is determined by the vengeful Naruni). From that point on, the target's actions and whereabouts and activities are recorded regularly. When an opportunity occurs to exact revenge by getting the upper hand over him, or cheating or ruining him, the Naruni will know it and consider making a move of retribution. As usual, such retribution usually involves money and valuables, or reputation, not outright murder or injustice. For the Naruni, revenge (and life for that matter) is a calculated chess game involving reputation and fortune.

What occurs next will vary with each particular Naruni. Some will log both the target's positive deeds as well as their negative ones, and eventually mitigate their comeuppance if it seems appropriate, perhaps simply cheating their rival or enemy out of a current deal, and not ruining his entire business. Other Naruni are only interested in what they can get out of the victim before finally crushing his business or slaughtering his reputation.

Many Naruni interact with their intended victim. This can be overtly or from behind the scenes (with the Naruni's true interest kept secret from the victim). The vengeful Naruni may even pretend to be a business partner or a friend (Naruni who hate each other are famous for putting aside their differences if the potential profit or mutual benefit is great enough). All Naruni carefully choose the moment for revenge to maximize their profit or the level of revenge.

At any rate, as long as the erstwhile enemy is providing the Naruni with some form of profit (whether financial or just amusement) or other benefit, the Naruni will defer their revenge. Depending upon the patience of the Naruni, and the specific circumstances, revenge could come years, decades, or even centuries after the original offense. There have been cases where certain individuals have been in a Naruni's Vengeance Volume for decades, but kept making a profit for the Naruni until they eventually passed away from natural causes, leaving the Naruni's revenge technically unfulfilled. However, in most cases, the target will either outlive their usefulness, or the Naruni will finally tire of being patient and lower the boom of long-delayed retribution on the enemy. Sometimes, those in the book don't even realize they offended the Naruni, or imagined that after all these years, the Naruni had forgotten all about them (not likely). Unfortunately, Naruni recognize no time limit on seeking revenge.

Although some Naruni will target anyone who ever interferes with them, most of them usually avoid seeking vengeance on fellow True Naruni or Uteni for petty infractions and fair business deals that get the better of them. Besides the resources and connections that these people can often bring against them as adversaries, a lot of Naruni do not take being bankrupted by these two races as a personal affront. Granted, the normal attitude is to eventually get even. However, the stigma of being outwitted or outmaneuvered by a true master of commerce is far less than it would be if they were tricked or outsmarted by members of a "lesser" race.

True Naruni who hire Uteni are typically very generous to them and forgive most infractions without ever putting them in the book. Only outright betrayal is cause for a Uteni to be counted as an enemy. Uteni are one of the favored subordinate races serving Naruni Enterprises, and the aliens have a knack at managing to stay on the good side of their erstwhile masters. This may be because the Uteni have a similar nature but are more thick skinned and less aggressive than their masters. Uteni will go out of their way to befriend and cultivate True Naruni in the hope that someday, if the Naruni claws his way back up the corporate ladder, the Uteni's acts of kindness will not be forgotten (they won't) and the Naruni will hire him/them to work in sales or management. More often than not, Naruni who have been assisted by Uteni do reciprocate in that fashion.

Curiously, the Vengeance Volumes are usually in the form of ledgers. Despite their high technology and access to advanced computers, Naruni prefer to keep their ongoing plans for revenge in a handwritten book. A Naruni very seldom entrusts his plans for retribution to electronic data form. Perhaps they fear that someone (possibly allied with their targets) will somehow hack into their database. Or perhaps they work out some of their emotions by handwriting the journal and keeping things a bit more personal than they'd like others to believe.

More on the Naruni, Uteni and Repo-Bots can be found in **Rifts® Dimension Book Two: Phase World®**, pages 44-49.

Molock Enforcers

Of the various races employed by the Naruni, there are two that are considered particularly loyal and useful. One is the *Uteni Shifters* (see **Rifts Dimension Book 5: Anvil Galaxy**, pages 50-51, for a more complete description of the Uteni specifically), the other is the *Molock Enforcers*. Both have served the Naruni for centuries and enjoy special status, treatment and privileges.

Molocks are an intelligent form of plant life. They are bipedal humanoids with two legs and, instead of arms, four tentacle-like limbs. Their heads are roughly humanoid with slots that resemble eyes and a large gash for a mouth (but no nose). The skin is rough, like tree bark, and mottled, with coloration ranging from drab greens to light browns, except during a battle-charge (see full description below). During the charge, the Molock's skin turns darker and hardens.

The origin of the Molocks is shrouded in mystery. One of the most common theories is that they were an experiment of the Gene-Splicers, who were attempting to increase the intelligence and mobility of certain plants. After creating the Molocks, the Splicers, as they so often do, left the sentient plants to fend for themselves. The Molocks were eventually discovered by Naruni and put to work. They started off as slave labor, but the plant beings actually appreciated the direction their Naruni bosses provided and responded with enthusiasm. The Naruni, quick to realize the benefits of having a labor pool of such willing workers, loosened their hold on the Molocks and gradually improved the beings' lot until they achieved the favored status they enjoy to this day. The Molocks don't seem to know their origin and simply accept that it is their duty or purpose to faithfully serve the Naruni. At any rate, the Molocks are a substantial part of Naruni Enterprises, surpassed in numbers only by the Uteni.

The Uteni are gifted salesmen and deal makers. They are invaluable to Naruni Enterprises as front men and often reach positions of management, usually mid- to high-level (some have actually made it to the Board of Directors). Conversely, the Molocks are strictly grunts, utilized mostly for repetitive and heavy labor, and by the *Naruni Debt Collection Division (NDCD)*. Molocks have proven themselves to be unimaginative but unshakably obedient and loyal employees, making them ideal as relentless NDCD agents who cannot be bribed, blackmailed or intimidated. Molocks prefer to have others make the decisions and are happiest when they have a strong leader and a clear cut chain of command to follow. The plant aliens like simple, straightforward assignments like, track down and get . . .



whoever or whatever (payment, property, information, etc.), or destroy this or that. Molocks seldom question an order no matter how odd it might seem, and are relentless in their duty to fulfill the task given them. Fearless and direct, they make outstanding enforcers, seeing that the master's will is done and intimidating weaker beings, as well as bodyguards, defenders and members of elite squads. Molocks do, however, tend to get a little out of their depth when they themselves have to take the initiative or be inventive. Hence, the most effective Molock teams are those headed by an Uteni or other non-Molock.

Molocks are frequently used to deal with clients, providing an intimidating presence in negotiations and whenever strong-arm techniques in persuasion are desired. They are as frightening as Repo-Bots (see *Rifts® Dimension Book 2: Phase World®*) and are often used for the same purpose. Most Molocks enjoy a good brawl, but they attack only when ordered to do so, and never for personal pleasure. Molocks who are ordered to stand down comply regardless of how ill-considered they feel their orders may be, but when unleashed in combat, they fight like demons. Despite their reputation for combat and being without mercy, Molocks can be the epitome of restraint, and be surprisingly polite, courteous, and helpful, at least until they are ordered to do otherwise, or their team leader or Naruni master (or his holdings) is threatened. Then watch out. Anyone who crosses a Molock will find their forbearance only goes so far. In most cases, a Molock will usually warn a troublemaker that they are reaching the danger point and any further bad behavior, or refusal to submit or comply will be met with violence.

When a Molock reaches this point, it is wise to heed his warning. Molocks do not bluff, and, once the fighting begins, they are seldom content to let their adversary go without administering what they feel is adequate punishment. Fortunately, it often takes Molocks ample provocation to work themselves into a battle frenzy. If they are allowed to cool off (such as when a troublemaker backs off and/or apologizes), they can quickly calm down. When not on duty, many Molocks are generally outgoing and friendly. However, Molocks do not hold life sacred and will kill whomever they are ordered to dispatch with little emotional qualms. Those who befriend Molocks will find that friendship is no barrier to a Molock assassin ordered to do away with them. The Molock may regret having to kill a friend, and may miss them afterward, but they will do as their master commands without question or hesitation.

Furthermore, Molocks don't hold grudges. Those who heed a Molock's warning or comply to their masters' demands are treated with as much courtesy as those who have been on good terms the entire time. The same holds true for actual opponents. Once a fight is over, unless the problem is an ongoing one, a Molock will treat his former adversary as if their previous fight never took place. As a result, Molocks are often assigned to security details, such as being bodyguards, or for escorting shipments of goods, protecting warehouses and other buildings, checking IDs and maintaining order at social events, meetings, negotiations, etc.

Molocks are utilized for debt collection in one of three situations: 1. If Repo-Bots are not readily available. 2. If their supervisors deliberately want to keep the Repo-Bots out of the operation (i.e. held in reserve, employ "nice guy" tactics first, etc.). 3. As support and backup for the Repo-Bots in large-scale

operations. Since the majority of Molocks greatly admire and respect power and leadership capabilities, most of them look forward to working *under* the highly intelligent Repo-Bots. For the most part, the Repo-Bots seem to appreciate the loyal and forceful Molocks. As long as things remain calm, the Molocks follow a Repo-Bot's orders to the letter. However, when Molocks get very excited or agitated, they tend to lose discipline and go into *battlecharge mode*. This makes it virtually impossible for anyone to keep their Molock troops under control. Then again, a battlecharge is typically a necessary last resort, and those commanding Molocks know what to expect. It has been said that the Molocks are the only race who can make the unemotional Repo-Bots sigh in frustration.

Although Molocks are an important part of the Naruni Enterprises workforce, many people are uncomfortable around them. For one thing, when push comes to shove, Molocks always side with their Naruni masters. This makes any friendships conditional, at best.

Alignment: Any, but 90% are Aberrant. Molocks of good alignments are rare and tend to be regarded by their fellows as eccentric or misguided.

Attributes: I.Q. 2D6+2, M.E. 3D6-1, M.A. 2D6, P.S. 4D6+20 (Supernatural), P.P. 2D6+3, P.E. 3D6+6, P.B. 1D6, Spd. 2D6 (x3 during a battlecharge).

Height: 7-8 feet (2.1 to 2.4 m) tall.

Weight: 450-500 pounds (202.5 to 225 kg).

M.D.C.: 2D6x10 +P.E. attribute number and 3D6 M.D.C. per level of experience.

Horror Factor: 10, but increases to 13 during a battlecharge.

P.P.E.: 2D6

Disposition: Most Molocks enjoy fighting. When they get the opportunity to battle a worthy adversary(s), they usually leap at the chance. However, very few of them are bullies. They feel that harassing someone weaker than themselves is a waste of time and proves nothing. When not engaged in combat or on duty as an enforcer, many Molocks are very amiable and friendly.

Average Life Span: 75 years.

Natural Abilities: Supernatural Strength and Endurance, resistant to pain (weapons inflict normal damage but the Molock is only about half as sensitive to pain as humans and can fight to 30 points below zero without suffering combat penalties before lapsing into a coma). Bio-regenerates 2D6 M.D.C. per hour and can regenerate lost limbs and body parts within 3D4x10 days. Invisible to infrared and heat sensors, impervious to most drugs and chemicals designed to hurt or affect humans and animal life, but suffers full damage from poison designed to kill plant life.

Heightened Senses (special):

1. Track and maneuver by smell alone: 62% +2% per level of experience. Roll once for every 1200 feet (720 m). A failed roll means the scent trail is temporary lost, but two successful rolls out of three means the trail has been rediscovered.

2. Identify common, known smells and airborne aromas: 75%. Range: 1200 feet (366 m).

3. Remember and identify a specific, unusual scent: 60% +1% per level of experience. Range: 600 feet (183 m).

4. Smell/sense the coming of rain, smoke and large fires:

50% +2% per level of experience. Range: One mile (1.6 km).

5. Accurately sense the wind direction: 58% +2% per level of experience.

6. Hear ultrasonic sounds; super keen hearing. Average range: 1600 feet (488 m).

Battlecharge (Special): The battlecharge is a unique condition that the Molock's gain when they reach their third level of experience. When in combat, the Molock can focus his attention on one particular target (either a person or an object) and works himself into a type of near-berserker rage. The Molock then paws the ground (similar to a bull) and his body goes through a physical transformation. The Molock's skin darkens and hardens (+1D6x10+18 M.D.C.) and the Molock grows bigger and more imposing (increase size by 20-30%). This whole process takes about seven seconds and uses up half the being's attacks for that initial melee round.

The battlecharge has been compared with the charge of a bull, with one major difference. In order to gore their target, bulls lower their heads when they charge. This allows the matorador to step aside and evade the bull. Molocks charge with their eyes forward, trained on their target, enabling them to adjust their charge to compensate for an opponent attempting to dodge. **Note:** When Molocks fight among themselves, they usually avoid invoking battlecharges. If the battlecharge is employed by one (or more) of the combatants, this is a good indication that the fight is a serious one.

The Battlecharge can only be used as an *attack*. It cannot be used as a defensive maneuver for evasion or escape. If used in an attempt to pursue a target already in retreat, the Molock must roll a D20 under his M.E. at -3 in order to trigger the charge rage and transformation. Higher level Molocks may choose to terminate the charge, but this will be a conscious decision not motivated by fear or panic.

Once a battlecharge has begun, lower-level Molocks (5th level and below) are psychologically incapable of stopping themselves and **MUST** somehow finish the charge attack. The charge is a mixed blessing to the Molock as it confers both advantages and disadvantages.

Advantages (for the duration of the charge):

1. The Molock's skin turns hard and mass and body weight increase by 20-30%, providing an extra 1D6x10+18 M.D.C.

2. Gains one extra melee attack.

3. Becomes fearless; impervious to Horror Factor and +2 to save vs possession and mind control.

4. The Molock's running speed is tripled. However, the Molock can only maintain this speed as long as he continues to engage his target in charge attacks.

5. Duration of a battlecharge (a combat frenzy): Molocks can only maintain the battlecharge for a short period: One melee round per every two levels of experience. Characters who are 1-5th level cannot stop fighting until the duration ends or their initial opponent is defeated, whichever comes first.

Once the battlecharge ends, it will take 4D6 minutes before the Molock can muster the energy to attempt another charge.

Molocks of 6th level experience and higher can attempt to stop their charge/battle frenzy at any point. To do so they need to roll under their M.E. attribute on a straight D20 roll. Higher level Molocks get a +1 bonus to roll under their M.E. for every

level above 6th. Note that experience only gives these Molocks the ability to voluntarily stop their charge. They are still incapable of performing other actions or changing targets during their charge.

The disadvantages include:

1. During a battlecharge, a Molock is incapable of performing any other action until the charge is concluded. Furthermore, the Molock's target will be the object of his initial focus. Even if the tactical situation changes, the Molock can NOT shift over to another target.

2. Since they are exclusively focused on their attack on that one target, the Molock is oblivious to anything else going on around him and receives no bonuses to parry or dodge incoming attacks from other opponents or counterattacks from his target.

3. Unless 6th level or higher, a Molock cannot stop a battlecharge even when the situation changes and it would be prudent to do so. For example, a Molock's human opponent suddenly metamorphs into its true form, an adult dragon. Although charging into the dragon may be nothing short of suicidal, the Molock cannot stop his charge.

4. During the transition (when the Molock is undergoing his changes), the Molock can still calm himself and go back to normal. However, when the transition is complete and the Molock has begun his actual run at his intended target, he can no longer prevent his charge (with the exception of rule #3 above). Once the charge begins, the fighting continues until the battle is finished or the duration of the frenzy ends, or the Molock is slain, whichever comes first.

When trying to break into Mega-Damage structures, a common tactic is to have large numbers of Molocks launch into a battlecharge and body slam into the structure, one after the other. In this case, there is only one concentrated attack that does Supernatural P.S. damage x3 to the structure. To charge again, the Molock runs back after slamming into the objective and charges again. Even the strongest Mega-Damage structures can be worn down by this onslaught of living battering rams.

Obstacle(s) that get interposed between the Molock and its intended target will have the warrior run through them, or bat or push them aside en route to the main target. As long as the target is in sight, the Molock will continue to charge at it, going over, under, around, or through anything, and anyone, in its way. Minor obstacles will just be plowed through, but significant obstacles sturdy enough to withstand the Molock's impact will halt the charge, and take the full damage and wrath of the charging creature.

If the intended target vanishes, departs, or is no longer viable, it will cause the Molock to stop and come out of the battle frenzy (takes one melee round), or the Enforcer may focus on another target within line of sight and located near where the original target stood. Characters with the power of flight, teleportation, intangibility, and similar can avoid the battlecharge and frustrate their Molock adversary. **Note:** Just hiding and/or turning invisible may not be an adequate defense. The Molock's keen senses of smell and hearing may still locate the hidden target/adversary.

Vulnerabilities: Sluggish in cold weather (reduce Spd by half), cold-based attacks inflict double damage, and the character is susceptible to defoliating chemicals: -5 to save vs gases,

sprays and other chemical attacks specifically designed to kill vegetation.

Experience Level: Average 1D6+2.

Combat: Hand to Hand: Expert for laborers, Martial Arts or Assassin for Enforcers. Even Molocks who do not take up a combat-related O.C.C. will get at least Expert combat training.

Attacks per Melee: Laborers: As per Hand to Hand and experience, +1 attack thanks to their four tentacles. Enforcers: As per Hand to Hand combat skill, +3 additional attacks per melee.

Damage: As per Supernatural P.S., a minimum of 2D6 M.D. per punch or kick, 4D6 M.D. on a power punch. The tentacles have a 15 foot (4.6 m) reach.

Bonuses: +1 on initiative, +2 to parry, +4 to disarm, +4 to pull punch, +5 to save vs Horror Factor, +3 to save vs disease, +2 vs psionics and possession. All of these are in addition to attribute bonuses.

Magic: None.

Psionics: None.

O.C.C.s: 80% of the Naruni's Molock are Enforcers, and 20% are involved in heavy labor.

R.C.C. Skills:

Language: Trade One (+20%)

General Repair & Maintenance (+15%)

Basic Mechanics (+5%)

Pilot: Two of Choice (+10%).

Running

W.P.: Modern: One of choice.

W.P.: Ancient: One of choice.

Hand to Hand: Expert for laborers, but Martial Arts or Assassin for Enforcers or any other type of combat role at the cost of one skill.

R.C.C. Related Skills: Select 8 R.C.C. Related skills, plus select two skills at levels 4, 8, and 12.

Communications: Any.

Domestic: Any (+10%).

Electrical: Basic Electronics only.

Espionage: Detect Ambush, Detect Concealment, and Interrogation Techniques only.

Mechanical: Aircraft Mechanics, Automotive Mechanics, or Locksmith only (+5%).

Medical: First Aid and Holistic Medicine only.

Military: Any (+10%).

Physical: Athletics, Body Building, Boxing, Climbing, Swimming, and Wrestling only.

Pilot: Any.

Pilot Related: Read Sensory Equipment and Weapon Systems only.

Rogue: Concealment, Find Contraband, Gambling, and Streetwise only.

Science: Mathematics: Basic and Advanced only.

Technical: Any (+5%).

W.P.: Any.

Wilderness: Any (+5%).

Secondary Skills: The character also gets to select five skills from the previous list. These are additional areas of knowledge

that do not get the bonus listed in parentheses. All Secondary Skills start at the base skill level.

Habitat: Molocks originate from a sub-tropical planet. They have adapted well to a variety of environments, but prefer tropical or sub-tropical environments with warm climates. Hate cold and snow.

Allies and Enemies: Most Molocks pride themselves as being loyal to the Naruni. Their friends and foes are generally those designated as such by their superiors. When left to their own resources, Molocks tend to respect anyone who is willing to fight them. Even if they are weaker and easily defeated. The mere fact that they were willing to stand up to them is enough to merit the Molocks' respect (and possible friendship).

Armor: Molocks prefer not to wear armor but will do so if ordered to by their superiors.

Weapons: Molocks generally prefer handheld melee weapons over ranged combat. In most cases, they feel the bigger the weapon, the better. If at all possible, they will use Vibro- and Plasma Axes (much to the chagrin of their Naruni masters). For ranged combat, they prefer big guns such as particle beam rifles and plasma ejectors over laser weapons or pistols.

Shulkh

Shulkh Tvarnik Quornall (pronounced "Shul-ukk-uhh Tee-vahr-nikk Kwor-naul") is Naruni Enterprises' new Manager of Special Operations on Rifts Earth. Shulkh is one of the leaders of his faction and the most offended by his faction's past defeat at the hands of the Coalition States, even though he was not the guy in charge at the time. He is a conniving weasel who is said to be able to sell anything to anyone.

Shulkh was brought in to "handle the Earth situation" and to inflict subtle retribution upon the CS. To this end, Shulkh has been granted a good deal of leeway as far as what tactics he may employ to accomplish his mission. Shulkh intends on expanding the Naruni presence in North America in such a way that it will harass, frustrate and defame the Coalition States and the Earth-based weapons manufacturers who worked against them last time. Though the CS and weapon manufacturers use murder as their most effective tool to destroy the Naruni presence in the Americas, Shulkh will not stoop to their level, using violence and killing only to defend Naruni personnel and operations that fall under direct attack. Even then, he will have his forces (which include a number of Molock Enforcers and a quartet of Repo-Bots) fight only enough to make good their escape. In grand Naruni tradition, Shulkh intends to hurt his faction's enemies by damaging their reputations and ruining them financially. Where the CS, Northern Gun and Manistique Imperium are concerned, he also plans to wage a psychological war that will make them paranoid, afraid and confused, never knowing when or where the Naruni may appear to threaten their little empires or to support other indigenous forces to strike against them. All are among Shulkh's specialties.

In an effort to convince his superiors of his commitment and that Naruni Enterprises should allocate more resources to Rifts Earth, Shulkh (never one for playing it safe) has put up a substantial portion of his personal fortune to finance this new venture. If all goes as he plans, he will not only make a substantial

profit, but avenge his faction's past defeat, and rebuild the clan's reputation as a group not to be trifled with.

Shulkh has already begun the restructuring of his personnel. Among the policies he is implementing is the increased use of Molocks. Before Shulkh's arrival, there were only a handful of Molocks on Rifts Earth. Shulkh brought a few dozen with him and plans on bringing in a few dozen more, as needed. He is also using "locals" as half of his sales staff (the rest being the baldheaded Uteni) as well as using humans and D-Bees as his eyes, ears, and pawns in the grand scheme of things. All are working out fine for the moment.

A hands-on type of manager, Shulkh is becoming personally involved in many details of the Earth NE operations, seeing where improvements can be made and which parts should be left alone. However, Shulkh is keeping a low profile. He knows most Earthlings think the Uteni are the Naruni, and that they have no idea of what a True Naruni looks like (they look like a humanoid elephant with a trio of serpents for their nose/trunk). Most of his work is done behind the scenes and the Naruni is relying heavily on his Uteni, such as Trader Joe (from *Rifts Mercenaries*, pages 74-75), and his local agents to act as his front men.

Current Name: Shulkh Tvarnik Quornall.

Species: True Naruni.

Alignment: Anarchist.

Attributes: I.Q. 22, M.E. 13, M.A. 17, P.S. 15 (Supernatural), P.P. 11, P.E. 13, P.B. 5, Spd. 11

Height: 7 feet (2.1 m) tall.

Weight: 460 lbs (207 kg).

M.D.C.: 116

Horror Factor: 12

P.P.E.: 53

Age: 187; in human terms, roughly equivalent to late 20's.

Disposition: Shulkh has always been a bit of a rebel (by Naruni standards). Given a choice between following the more common course of action vs the less-traveled path, he will almost invariably opt for the latter. He plays the game of corporate politics well, thinks quickly and, so far, has thrived in his faction, but he also relishes personal freedom and going his own way, or at least putting his own spin on things whenever possible. In human terms, Shulkh would be considered as an up and coming hotshot (the term "Young Turk" comes to mind) who is inventive, resourceful, fast talking and skilled at flying by the seat of his pants when he finds himself in new territory or an awkward situation. Very little flusters him, and he loves a challenge, hence he is volunteering for the Earth assignment.

As a manager, Shulkh is not afraid to take chances that many of the more conservative Naruni would choose to avoid. He is also skilled at surrounding himself with capable managers and reliable hired help. He is also glad to delegate authority to those he trusts. Shulkh supports his subordinates and has no problem rewarding those who are particularly effective and loyal to him. However, those subordinates who are under Shulkh's immediate control and supervision are a different matter. The other employees are given a fair amount of freedom. If they screw up, they answer to their supervisor. But the employees that are directly answerable to Shulkh are watched more closely and given

less leeway. Anyone who does not produce well at this level is either demoted or sacked. This policy is well known among long-time employees of Shulkh, many of whom are content to remain at least two or three corporate levels below their Naruni boss. This strategy has worked well for Shulkh in the past and his record as a manager is impressive, with a steady line of successes to his credit. However, all of his past performances were on a much smaller scale than his present assignment.

To Shulkh, Rifts Earth represents a golden opportunity. If he succeeds, it will mean a major step up the corporate ladder. However, a failure will result in demotion and a severe setback to his career. This is not something that Shulkh is prepared for and he is determined to deal severely with anyone or anything that stands in his way.

Experience Level: 8th level True Naruni R.C.C.

Natural Abilities: Supernatural Strength and endurance, very long lived, and can heal 1D6x10 M.D.C. per every eight hour period. Three prehensile, tentacle- or trunk-like noses with biting mouths at the end that have a 5 foot (1.5 m) reach and do 1D4 M.D. per attack. The noses can also be used like tentacles to pick up and use weapons and tools (but without any bonuses and at a -15% skill penalty).

Skills of Note: Speak Trade Tongues One through Six, Math: Basic & Advanced, Computer Operation, Basic Electronics, Armorer/Field Armorer, Pilot Hover Craft, all at 98%, Aircraft Mechanics 53%, Computer Repair 83%, Concealment 66%, Electrical Engineering 88%, Electricity Generation 78%, First Aid 88%, Gambling 73%, Intelligence 78%, Interrogation Techniques 73%, Lore: Demon & Monster 78%, Mechanical Engineering 83%, Navigation 88%, Pick Pockets 68%, Pilot Jet Aircraft 76%, Read & Operate Sensory Equipment 78%, Recognize Weapon Quality 78%, Robot Electronics 73%, Robot Mechanics 78%, Ship to Ship Combat 48%, Space Defense Systems 73%, Trap Construction 56%, Vehicle Armorer 88%, Weapons Engineer 88%, W.P. Automatic Pistol, W.P. Energy Pistol, and W.P. Whip.

Combat Skills: Hand to Hand: Basic.

Number of Attacks: Five.

Bonuses: +1 to strike, +2 to parry, +2 to dodge, +2 to roll with punch/fall/impact, +2 to pull punch, +2 to damage, +1 to entangle, kick attack doing 1D6 damage, critical strike on unmodified roll of 19-20, judo-style body throw/flip (does 1D6 damage, and victim loses initiative and one attack per melee), +6 to save vs Horror Factor, +3 to save vs disease, 45% to inspire trust or intimidate.

Magic: None.

Psionics: All the Sensitive powers plus Automatic Mind Block, Bio-Manipulation and Empathic Transmission. Considered to be a Master Psionic. I.S.P.: 90.

Weapons: Shulkh prefers not to carry weapons or do his own fighting. He maintains a contingent of seven Molock bodyguards and three Uteni retainers (assistants) to deal with most situations. However, if forced to defend himself, Shulkh can requisition state-of-the-art weapons and equipment from his Naruni Enterprises inventory.

Armor: Shulkh often wears concealed armor and/or a force field projector under his cloak. This armor is custom-made and Shulkh has spared no expense to make the armor comfortable as well as provide protection.

Equipment of Note: Shulkh has immediate access to virtually any equipment presented in this book that is the property of Naruni Enterprises. If there is something that he needs that NE does not already own, he can usually trade for it or purchase it. If the item(s) is not for sale and the Naruni truly needs (or desires) it, his Molocks are on hand to attempt to procure the item(s) by whatever means at their disposal, or he may hire "local talent" to do his dirty work.

Description: Shulkh is a heavy-set True Naruni of average height. He is youngish and dresses a tad more flamboyantly than most of his fellows.

Money: Shulkh's personal fortune is currently at several billion credits. At any given time, he has a couple of million within easy access for emergencies. As a manager for Naruni Enterprises, he can request millions more for business related operations. Note that any such requests require authorization from Shulkh's superiors and may be refused (generally depending upon the current situation).

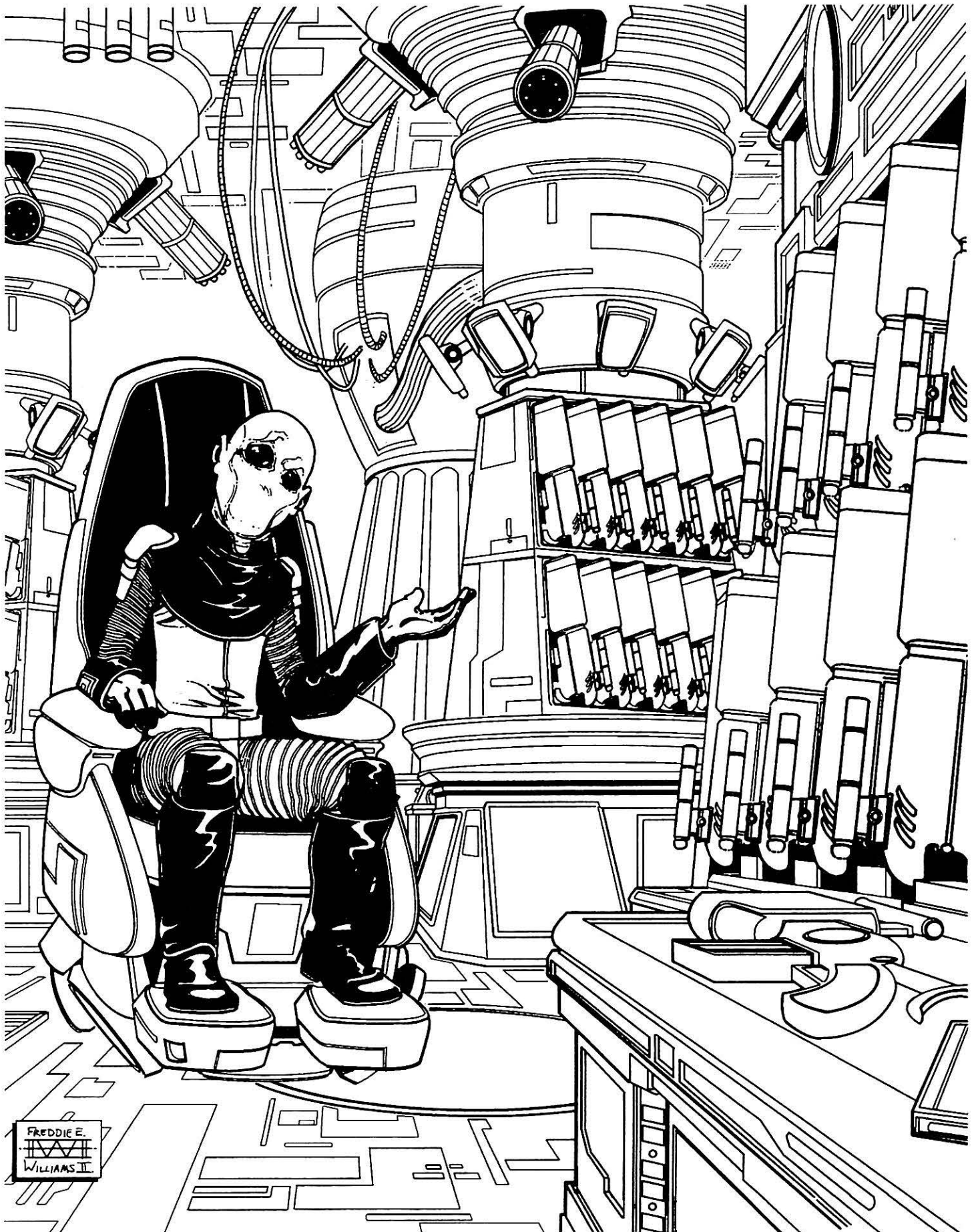

Naruni Enterprises Summer Catalog

By Carmen Bellaire & Kevin Siembieda

Circa 109 P.A. – Rifts Earth

Dear Customer,

Naruni Enterprises has been absent from the North American marketplace the last few years due to unforeseen circumstances. However, we are back – with a vengeance, you might say.

You hold in your hands Naruni Enterprises' latest catalog. It is packed full of high-powered weapons, maximum protection body armor, and an array of wonderful new power armor and vehicles for every conceivable purpose. All feature Naruni Enterprises' latest advancements in the fields of metallurgy, poly-alloys and weapon architecture that are sure to outshoot and outperform anything else on the market.

Make certain you take special note of our new Thermo-Kinetic Armor, new line of Vibro-Blades and our new jacketless projectile weapons among many other innovations.

Whether opposing jack-booted empires, battling monsters, embarking on adventure or just looking for a little personal protection, we want Naruni Enterprises to be your first and last stop for combat purchases. And remember, one can never have too much protection.

Watch for our traveling sales force to visit your town.

– Naruni Enterprises Earth Management Team

Favorite Back Stock

Instead of boring you with page after page of descriptions of our long back stock inventory, I would ask you to refer to our year 108 P.A. catalog to find the old, tired and true favorites (see *Rifts® Game Master Guide*, or *Rifts® Mercenaries* and *Rifts® Phase World® Sourcebook*), but here is a convenient list of these dependable weapons, vehicles and items along with their list retail price. These best sellers are always available from Naruni Enterprises and will remain part of our inventory for years to come. After all, old guns never die, they just become collectors' items and companions that keep on giving.

WARNING: All weapons in this catalog are banned by the Coalition States and the possession of one is an automatic death sentence. Then again, our costumers are not afraid of the Coalition, are they?

Naruni Firearms:

NE-H10 Plasma Derringer (see *Rifts® Phase World® Sourcebook*, pg. 53, and in the *Rifts® G.M. Guide*, page 151). Retail Market Value: 10,000 credits.

NE-2L Plasma Cartridge Auto-Pistol (see *Rifts® Phase World® Sourcebook*, pg. 53, and in the *Rifts® G.M. Guide*, page 151). Retail Market Value: 10,000 credits.

NE-4 Plasma Cartridge Pistol (see *Rifts® Mercenaries*, pg. 123, *Rifts® Phase World®*, pg. 117, or *Rifts® G.M. Guide*, pg. 151). Retail Market Value: 25,000 credits.

NE-6 Magnum Plasma Cartridge Revolver (see *Rifts® Phase World® Sourcebook*, pg. 52, and in the *Rifts® G.M. Guide*, page 151). Retail Market Value: 15,000 credits.

NE-10 Plasma Cartridge Rifle (see *Rifts® Mercenaries*, pg. 122, or *Rifts® Phase World®*, pg. 117, and in the *Rifts® G.M. Guide*, page 151). Retail Market Value: 40,000 credits.

NE-28R Micro-Missile Wrist Launcher (see *Rifts® Phase World® Sourcebook*, pg. 57, and in the *Rifts® G.M. Guide*, page 153). Retail Market Value: 50,000 credits.

NE-50 Particle Beam Rifle (see *Rifts® Mercenaries*, pg. 123, *Rifts® Phase World®*, pg. 117, or *Rifts® G.M. Guide*, pg. 151). Retail Market Value: 45,000 credits.

NE-74GL Grenade Launcher (see *Rifts® Phase World® Sourcebook*, pg. 55, or *Rifts® G.M. Guide*, pg. 152). Retail Market Value: 75,000 credits.

NE-75H Shoulder Cannon (see *Rifts® Phase World® Sourcebook*, pg. 54, or *Rifts® G.M. Guide*, pg. 151). Retail Market Value: 80,000 credits, plus 5000 for conversion kit.

NE-95 Double Threat Assault Rifle (see *Rifts® Phase World® Sourcebook*, pg. 54, or *Rifts® G.M. Guide*, pg. 151). Retail Market Value: 42,000 credits.

NE-195 Plasma Ejector Assault Rifle (see *Rifts® Phase World® Sourcebook*, pg. 55, or *Rifts® G.M. Guide*, pg. 152). Retail Market Value: 50,000 credits.

NE-200 Plasma Cartridge Machine-Gun (see *Rifts® Mercenaries*, pg. 123, *Rifts® Phase World®*, pg. 117, or *Rifts® G.M. Guide*, pg. 152). Retail Market Value: 95,000 credits.

NE-300 Stutterer Plasma Cartridge Submachine-Gun (see *Rifts® Phase World® Sourcebook*, pg. 52, or *Rifts® G.M. Guide*, pg. 152). Retail Market Value: 20,000 credits.

NE-600 Pulse Laser (see *Rifts® Phase World® Sourcebook*, pg. 53, or *Rifts® G.M. Guide*, pg. 152). Retail Market Value: 30,000 credits.

NE-800R Missile Assault System (see *Rifts® Phase World® Sourcebook*, pg. 53, or *Rifts® G.M. Guide*, pg. 153). Retail Market Value: 80,000 credits.

NE-1000 Plasma Ejector Rifle (see *Rifts® Mercenaries*, pg. 124 or *Rifts® G.M. Guide*, pg. 152). Retail Market Value: 36,000 credits.

Naruni Vehicles:

NE-010 Destructo-Drone (see *Rifts® Mercenaries*, pg. 126). Retail Market Value: 250,000 credits.

NE-020 Combat Drone (see *Rifts® Mercenaries*, pg. 127). Retail Market Value: 4 million credits.

NE-030 Spy Drone (see *Rifts® Mercenaries*, pg. 128). Retail Market Value: 8 million credits.

NE-120B Carnivore Mark I – Light Hover Tank (see *Rifts® Mercenaries*, pg. 130). Retail Market Value: 40 million credits.

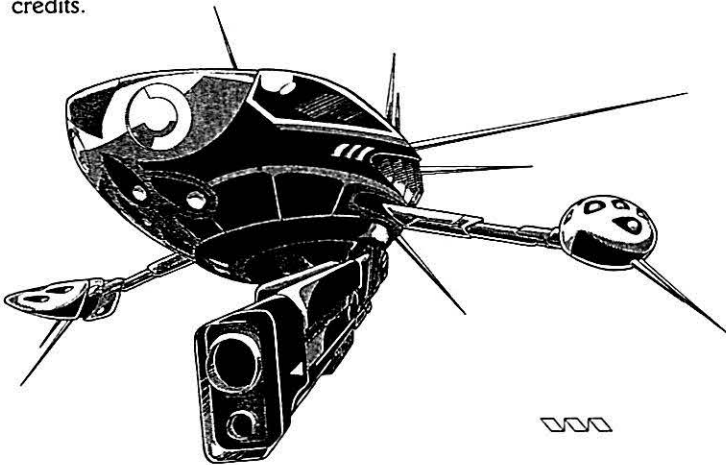

NE-300V OMAV Combat Pod (see *Rifts® Mercenaries*, pg. 128). Retail Market Value: 50 million credits, 55 million with VR system.

NE-B-AA14 Boomerang Attack Aerodyne (see *Rifts® Mercenaries*, pg. 140). Retail Market Value: 8 million credits.

NE-CM-DW1000 Crescent Moon Delta-Wing Space Plane (see *Rifts® Mercenaries*, pg. 139). Retail Market Value: 50 million credits.

NE-DK-AR500 Death-Knight Assault Robot (see *Rifts® Mercenaries*, pg. 136, or *Rifts® G.M. Guide*, pg. 228). Retail Market Value: 90 million credits.

NE-FB-49 Fire-Eater Attack Ship (see *Rifts® Phase World® Sourcebook*, pg. 83). Retail Market Value: 70 million credits.

NE-J2 Juggernaut – Heavy Hover Tank (see *Rifts® Mercenaries*, pg. 132). Retail Market Value: 60 million credits, 80 with force field.

NE-MK-PA12 Mecha-Knight – Medium Power Armor (*Rifts® Mercenaries*, pg. 134, or *Rifts® G.M. Guide*, pg. 214). Retail Market Value: 25 million credits.

NE-NSR20 Nomad – Scout Robot (see *Rifts® Mercenaries*, pg. 138, or *Rifts® G.M. Guide*, pg. 228). Retail Market Value: 20 million credits.

NE-O-AR600 Ovoid Combat Robot (see *Rifts® Phase World® Sourcebook*, pg. 73, or *Rifts® G.M. Guide*, pg. 228). Retail Market Value: 95 million credits.

NE-PAE-1000 Enforcer Power Armor (see *Rifts® Phase World® Sourcebook*, pg. 67, or *Rifts® G.M. Guide*, pg. 214). Retail Market Value: 4 or 5 million credits.

NE-SF10 Broadsword Delta-Wing – Multi-Environment Fighter (see *Rifts® Phase World®*, pg. 160). Retail Market Value: 65 million credits.

Other Naruni Items:

NE-000MX Naruni Magazines: Empty. Retail Market Value: 20 credits each.

NE-GF10 Fragmentation Grenades (see *Rifts® Phase World® Sourcebook*, pg. 56, or *Rifts® G.M. Guide*, pg. 153).

Retail Market Value: 400 credits per grenade.

NE-GF20 Fragmentation Micro-Grenades (see *Rifts® Phase World® Sourcebook*, pg. 56, or *Rifts® G.M. Guide*, pg. 153). Retail Market Value: 300 credits per grenade.

NE-GHE10 High Explosive Grenades (see *Rifts® Phase World® Sourcebook*, pg. 56, or *Rifts® G.M. Guide*, pg. 153). Retail Market Value: 500 credits per grenade.

NE-GHE20 High Explosive Micro-Grenades (see *Rifts® Phase World® Sourcebook*, pg. 56, or *Rifts® G.M. Guide*, pg. 153). Retail Market Value: 350 credits per grenade.

NE-C10 Camouflage Sheets (see *Rifts® Mercenaries*, pg. 125). Retail Market Value: 15,000 credits per 10 square feet (1 square meter).

NE-C20 Camouflage Variable Armor (see *Rifts® Mercenaries*, pg. 124). Retail Market Value: 75,000 credits.

NE-K-HEX Killaryte HE Plastique Cubes (see *Rifts® Phase World® Sourcebook*, pg. 56, or *Rifts® G.M. Guide*, pg. 153). Retail Market Value: 1000 credits per cube.

NE-M-M-D Naruni Dumb AP Micro-Missiles (see *Rifts® Phase World® Sourcebook*, pg. 56, or *Rifts® G.M. Guide*, pg. 153). Retail Market Value: 1600 credits per missile.

NE-M-M-S Naruni Smart AP Micro-Missiles (see *Rifts® Phase World® Sourcebook*, pg. 56, or *Rifts® G.M. Guide*, pg. 153). Retail Market Value: 8000 credits per missile.

NE-F12A Light Force Field (see *Rifts® Mercenaries*, pg. 125, *Rifts® Phase World®*, pg. 121, or *Rifts® G.M. Guide*, pg. 198). Retail Market Value: 40,000 credits.

NE-F20A Medium Force Field (see *Rifts® Mercenaries*, pg. 125, *Rifts® Phase World®*, pg. 121, or *Rifts® G.M. Guide*, pg. 198). Retail Market Value: 60,000 credits.

NE-F40A Heavy Force Field (see *Rifts® Mercenaries*, pg. 126, *Rifts® Phase World®*, pg. 122, or *Rifts® G.M. Guide*, pg. 198). Retail Market Value: 120,000 credits.

NE-F50A Super-heavy Force Field (see *Rifts® Mercenaries*, pg. 126, *Rifts® Phase World®*, pg. 122, or *Rifts® G.M. Guide*, pg. 198). Retail Market Value: 200,000 credits.

Note: Also see our line of K-HEX warheads and guided missiles (see *Rifts® Phase World® Sourcebook*, pg. 55). Retail Market Value: varies.

(G.M. Note: Prices on Phase World and in the Three Galaxies may differ from those on Rifts Earth for the same product. Many are 25-30% higher on Earth, sometimes double or triple, like the Plasma Cartridges, due to the higher cost of doing business in a hostile territory and the fact that they are rare, trans-dimensional imports available nowhere else in the world. Furthermore, some of the weapons, gear and vehicles listed many not be available to the Earth market, or in short supply at double the usual cost. Most Naruni items are comparatively uncommon on Earth and spacecraft are not available on Rifts Earth. Naruni Enterprises advanced technology makes many of their weapons and equipment superior in firepower, M.D.C. and/or ability, which is why the other weapons manufacturers are out to destroy them and stop their sale. G.M.s may want to reduce Mega-Damage by 1D6 to 2D6 if you think these more advanced weapons will imbalance the game. Then again, from the Naruni standpoint that's exactly the idea – to give the underdogs superior weapons to take on the CS. Naruni weapons, armor and vehi-

cles are in short supply compared to the number of cheaper, Northern Gun, Manistique, Wellington, Wilk's, Black Market, Triax and other weapons on the market. Naruni sales represent less than 2% of the entire market and are not expected to grow beyond 4%. And since the NE sales reps are constantly on the move, finding a Naruni when one needs one may be difficult to impossible. Thus, buyers who want NE gear need to stock up whenever they happen to run across a traveling Naruni salesman.)

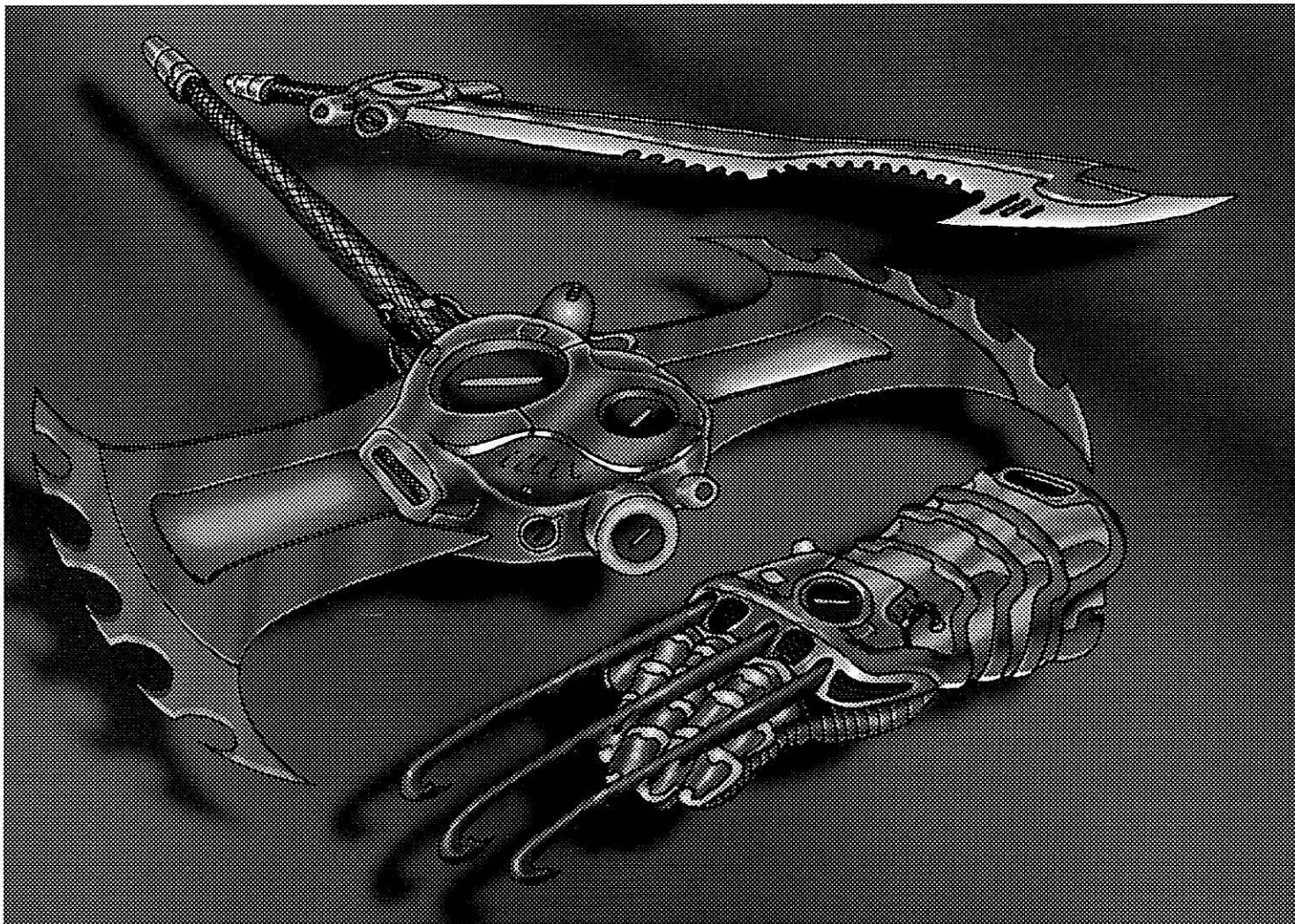

New NE Weapons

The Research and Development Department at Naruni Enterprises has been hard at work tweaking old technology for better performance, procuring different weapon designs from across the Megaverse, and developing revolutionary breakthroughs in weapons technologies for your protection and amusement. As always, Naruni weapons have been thoroughly field tested for maximum reliability and performance. In a firefight you need to know your weapon is there for you, and NE weapons always work! Remember, if it's not Naruni Enterprises, it's an unknown quantity.

Forget the rest, choose the best – Naruni Enterprises.

Ripper Vibro-Blades

Ripper Vibro-Blades: All Vibro-Blades are blade weapons surrounded by an invisible, high-frequency energy field that gives them Mega-Damage capabilities. The engineers at Naruni Enterprises' R & D Department have found a way to surround a Vibro-Blade in multiple Vibro-energy fields simultaneously. The secret to the new Ripper Vibro-Blades is that a computer chip in each weapon randomly flicks the different Vibrational fields on and off at different intervals to randomly alter the field and cause the blade to rip and tear through its target like a chain saw! The end result is greater versatility and damage, and the weapon leaves a nasty, jagged wound that is slower to heal (takes a few days longer to heal without surgery, magic or psionic healing).

Ripper Vibro-Blades are ideal for both combat and industrial use (cutting and sawing).

As an added feature for the inhabitants of Rifts Earth who might have to deal with supernatural nasties and hungry undead, the Ripper Blades come standard with a silver coating on every blade.

And finally, each Ripper Vibro-Blade is wickedly serrated to give it a unique look from standard Vibro-Blades and so you know that you're holding something special.

NE-RV01 Ripper Vibro-Knife: Mega-Damage: 2D4 M.D. Weight: 1 lb (0.45 kg). Cost: 10,000 credits.

NE-RV02 Ripper Vibro-Bayonet: Designed as an attachment to a variety of rifles (all NE style rifles): Mega-Damage: 3D4 M.D. Weight: 1 lb (0.45 kg). Cost: 11,000 credits.

NE-RV03 Ripper Vibro-Saber (short sword): Mega-Damage: 4D4 M.D. Weight: 3 lbs (1.35 kg). Cost: 14,000 credits.

NE-RV04 Ripper Vibro-Sword (large, one-handed sword): Mega-Damage: 3D6 M.D. Weight: 4 lbs (1.8 kg). Cost: 18,000 credits.

NE-RV05 Ripper Vibro-Robot Sword (giant): Designed for use as a two-handed sword for oversized power armor and large cyborgs, or a short sword for giant robots. Mega-Damage: 5D6 M.D. Weight: 10 lbs (4.5 kg). Size: 6-8 feet (1.8 to 2.4 m) long. Cost: 30,000 credits.

NE-RV06 Ripper Vibro-Spear: Mega-Damage: 2D6 M.D. Weight: 3 lbs (1.35 kg). Cost: 13,000 credits.

NE-RV07 Ripper Vibro-Axe: Mega-Damage: 4D6 M.D. Weight: 4 lbs (1.8 kg). Cost: 22,000 credits.

NE-RV08 Ripper Vibro-Pole Arm: Large blade pole arms, like halberds, glaives, pikes, scythes, and similar. Mega-Damage: 4D6 M.D. Weight: 3 lbs (1.35 kg). Cost: 24,000 credits.

NE-RV09 Ripper Vibro-Claws: Three hooked blades attached to a forearm gauntlet or protective plate. Mega-Damage: 3D6 M.D. Great for blocking (+1 to parry) and slashing (+1 to strike). Claws fall into the W.P. Knife category. Weight: 3 lbs (1.35 kg). Cost: 15,000 credits.

NE-RV0X Ripper Vibro-Armor Spines: A set of three Ripper Vibro-Blades that can be added to any suit of NE body armor or power armor; typically used like Vibro-Claws or attached to the forearm, elbow, shoulders and head/helmet. Mega-Damage: A body slam or tackle with the Vibro-Spines does 3D6 M.D. Also anyone grappling with a spiked armored figure takes damage if they grab and stab or slice themselves with the spines. Weight: 8 lbs (3.6 kg). Cost: 15,000 credits.

New! Slim-Line Weapons

Research shows Naruni weapons are some of the sturdiest, most reliable weapons on the market. A study has shown that humans and other Earthlings, however, find some Naruni weapons too bulky, despite the fact that most provide superior firepower. Size, weight and the ability to conceal a weapon is of particular concern for mercenaries, covert operatives and adventurers, as well as civilians who don't want to broadcast they are carrying a weapon. Naruni weapons have remained at their current size for centuries because of the heavy cooling jackets needed to handle

the excess heat created by the firing of our plasma cartridge rounds. This makes it difficult to reduce size without sacrificing firepower, until now.

Introducing NE Slim-Line Weapons created with humans and those with a need to conceal their firearms in mind. These weapons use the same Thermo-Kinetic alloys incorporated into our new line of body armor to create a sleeker weapon with excellent stopping power. Slim-Line weapons are being introduced for the first time anywhere, on Rifts Earth, so this is your chance to be the first to use this cutting-edge technology. Slim-Line weapon advances also enable NE to create several new multiple weapon systems for the buyer who wants to keep all his lethal options a trigger pull away. So if you are looking for the final solution to your problems, Naruni Enterprises' Slim-Line may provide the answer.

AMMO WARNING: If there is a drawback with the Slim-Line and traditional Plasma Cartridge weapons, it is that Plasma Cartridges are exclusively available only from Naruni Enterprises. Unfair tactics by competitors and ongoing persecution by the Coalition States may make availability of Plasma Cartridges extremely limited, so stockpile large quantities of ammo when you get the chance.

Types of Plasma Cartridges

NE-001PC "Light" Plasma Cartridge: Damage: 3D6 M.D. Cost: 15 credits each or 1200 credits of a box of 96.

NE-002PC "Medium" Plasma Cartridge: Damage: 5D6 M.D. Cost: 20 credits each or 1700 credits for a box of 96.

NE-003PC "Standard" Plasma Cartridge: Damage: 1D4x10 M.D. Cost: 30 credits each or 2600 credits for a box of 96.

NE-004PC "Heavy" Plasma Cartridge: Damage: 1D6x10 M.D. Cost: 75 credits each or 7000 credits for a box of 96.

NE-005PC "Super-Heavy" Plasma Cartridge: Damage: 2D4x10 M.D. Cost: 150 credits each or 13,000 for a box of 96. Note: Reserved for special, heavy weapons such as cannons and machine-guns; rare on Rifts Earth.

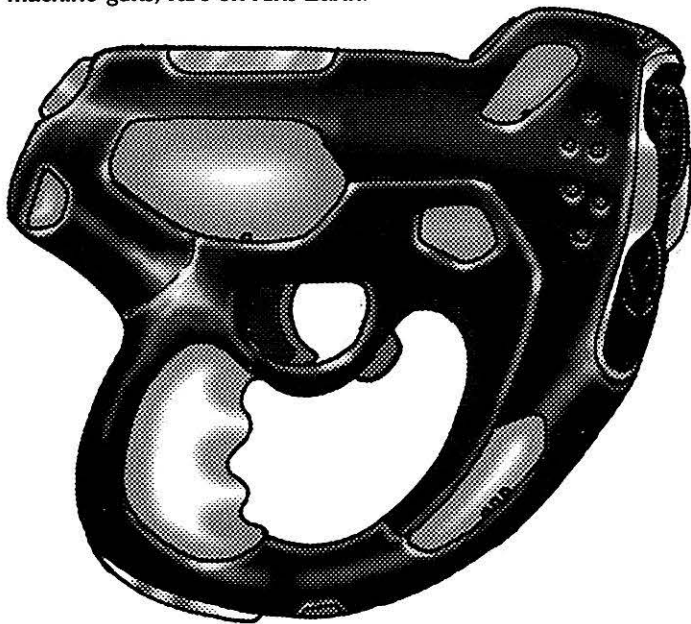

NE-3 Slim-Line "Gambler" Revolver

Made for gamblers, scholars, scoundrels and rogues, the NE-3 is a small, light revolver designed for easy concealment

(+20% to conceal the NE-3). The “Gambler” still packs quite a punch for its small size, and can be quite deadly at the card table and on the streets of the Chi-Town ‘Burbs when no one is wearing their heavy body armor. The NE-3 also makes a nice backup piece for you real gunfighters!

Weight: One lb (0.45 kg).

Mega-Damage: 3D6 M.D. per each plasma round.

Rate of Fire: Each shot counts as one melee attack.

Range: 200 feet (61 m).

Payload: Three NE-001PC Light Plasma Cartridges in a cylinder. Reloading the weapon takes one melee action per cartridge or one melee action to load all three if a speed loader (50 credits) is used.

Bonus: Due to the NE-3’s superior balance the weapon is +1 to strike on an aimed shot.

Cost: 15,000 credits. Each “light” plasma cartridge costs 15 credits.

NE-6SL Slim-Line “Magnum” Revolver

With the success of the standard NE-6 Magnum revolver, Naruni Enterprises decided that the Magnum deserved to get a facelift with a new Thermo-Kinetic alloy barrel to improve its balance and give the weapon even more of an “Old West” feel. The company is very happy with the results and we think you will be too. May I present to you the new NE-6SL Magnum Revolver.

Weight: 5 lbs (2.25 kg).

Mega-Damage: 1D4x10 M.D. per each plasma round.

Rate of Fire: Each shot counts as one melee attack.

Range: 500 feet (152 m).

Payload: Six of the NE-003PC “Standard” Plasma Cartridges (1D4x10 M.D. each) in a cylinder, or 12 NE-001PC Light Plasma Cartridges (each shot doing 3D6 M.D.) in a special, easy to remove cylinder. Reloading the weapon takes one melee action per cartridge, or one melee action to load all six (or 12 for light) rounds when a speed loader (200 credits each) is used.

Bonus: Due to the NE-6SL’s improved balance the weapon is +1 to strike on an aimed shot.

Cost: 30,000 credits. Each “Standard” Plasma Cartridge costs 30 credits.

NE-8SL Slim-Line “Barrage” Plasma Cartridge Auto-Pistol

The NE-8SL is a “light” version of the NE-4 pistol that fires the NE-001 “Light” Plasma Cartridge, providing a larger payload and excellent stopping power for most Earth-based encounters. This light weapon is excellent for urban environments and close combat in confined areas (streets and hallways) where good firepower and a large payload are desirable.

Weight: 3 lbs (1.35 kg)

Mega-Damage: 3D6 M.D. per single shot or 6D6 per rapid-fire burst (two rounds).

Rate of Fire: Each shot counts as one melee attack.

Effective Range: 500 feet (152 m).

Payload: 24 shot magazine containing NE-001PC Plasma Cartridges.

Cost: 15,000 credits. Each “Light” Plasma Cartridge costs 15 credits.

NE-202 Slim-Line “Widow-Maker” Heavy Plasma Cartridge Pistol

The newest heavy pistol from Naruni Enterprises is the “Widow-Maker” pistol that fires NE-004 “Heavy” Plasma Cartridges. While the new Widow-Maker does use Thermo-Kinetic alloy technology, a cooling jacket is needed because of the incredible amount of concentrated heat given off from the NE-202’s heavy plasma rounds. This results in a weapon that looks very much like the NE-4 Plasma Cartridge Pistol, but packs twice the firepower. The main disadvantage to the weapon is its rather short range, just 60 feet (18.3 m) and the fact that a strength of 18 or better is required to shoot the NE-202 (those with a lower P.S. are -5 to strike and will be knocked off their feet and lose one melee action when the weapon is fired). A normal P.S. of 24 (or Supernatural P.S. of 16) is required to fire the NE-202 one handed and then the shooter is still at -1 to strike. This is why the NE-202 pistol comes with an attachable shoulder stock.

Weight: 8 lbs (3.6 kg).

Mega-Damage: 1D6x10 M.D. per each plasma round.

Rate of Fire: Single shots only; each counts as one melee attack.

Range: 60 feet (18.3 m).

Payload: Four shot magazine of the NE-004PC Heavy Plasma Cartridges. Cannot substitute lighter rounds.

Penalties: -1 to strike for those with a P.S. of 18-24. A conventional P.S. of 25 (or robotic or bionic P.S. of 20) or higher has no penalty. Those with a P.S. lower than 18 are -5 to strike, are knocked off their feet and lose one melee attack and initiative.

Cost: 44,000 credits. Each “Heavy” Plasma Cartridge costs 75 credits.

NE-9DB Slim-Line Double-Barreled Plasma “Shotgun”

The new double-barreled plasma shotgun was Naruni Enterprises’ first experiment with the new Slim-Line weapons. While it still has the traditional two inch wide barrel of all Naruni weapons, the NE-9DB no longer has the heavy cooling jacket. This makes the weapon lighter and more appealing. Add to this the double-barrel configuration, and the plasma shotgun reminds one of an “Old West” large bore shotgun or an elephant gun. The real gunfighters of the New West loved it! Recommended for real men, cyborgs and large D-Bees only. (Note: The weapon is about 4 feet/1.2 m long and has a powerful kick, requiring a P.S. of 20 or better to fire it accurately; all others are -1D6 to strike, and those with a P.S. of 12 or less will be knocked on their butt and lose one melee action when the weapon is fired. A P.S. of 30 or a Supernatural P.S. of 18 or higher is required to fire the NE-9DB one handed, and the shooter is still -1 to strike).

Weight: 12 lbs (5.4 kg).

Mega-Damage: A single shot does 1D4x10 M.D. using the "Standard" Plasma Cartridge or 2D4x10 M.D. firing both barrels simultaneously. Or the weapon may fire the NE-004PC Heavy Plasma Cartridge which does 1D6x10 M.D. per round, or 2D6x10 M.D. per two-barrel blast. **WARNING:** Use of the heavy rounds requires the shooter to allow 15 seconds (one melee round) between attacks to allow the weapon to cool before firing again. Shooting without allowing sufficient cooling time (15 seconds) has a 01-76% chance of both rounds exploding in the weapon when the gun is fired, destroying the barrel (costs 25,000 credits to repair) and inflicting 2D4x10 M.D. to the shooter.

Rate of Fire: Two single shots (each counting as one melee attack) or a simultaneous double-barreled shot (counts as one melee action).

Range: 600 feet (183 m); the weapon affects a three foot (0.9 m) radius, double when both barrels are fired.

Payload: Two rounds, and can fire either the NE-003 "Standard" Plasma Cartridge (1D4x10 M.D.) or the NE-004PC "Heavy" Plasma Cartridge (1D6x10 M.D.); one in each barrel. It takes three melee actions to reload the NE-9DB, one to crack open the barrels and one to load each cartridge (the plasma shotgun is loaded in the same manner as a pre-Rifts double-barrel shotgun), but a trained fighter who is familiar with shotguns can load both barrels in two melee actions.

Note: The plasma shotgun can be "sawed-off" by cutting away most of the barrel length and at least half of the stock, shortening the weapon to about one foot (0.3) long, but the range is reduced to just 100 feet (30.5 m) and the accuracy is poor, -2 to strike.

Cost: 65,000 credits. Each "Heavy" Plasma Cartridge costs 75 credits.

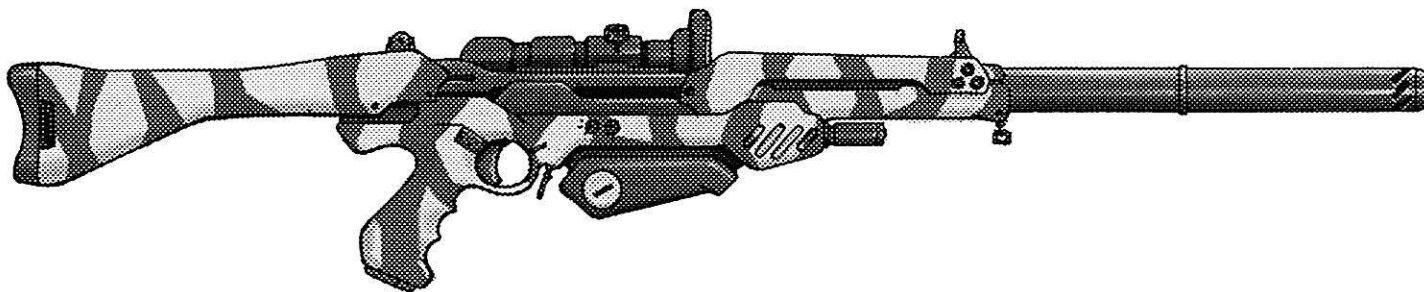

NE-11 Slim-Line Plasma Cartridge Rifle

This heavy, long-range rifle weapon fires the "standard" NE-003PC round and is ideal for dinosaur hunting, picking off Gargoyles and taking pot shots at SAMAS. The rifle uses the new Thermo-Kinetic alloy technology to produce a field infantry rifle with the punch of many heavy weapons. Range is much inferior to laser weapons, but on par with other heavy weapons and superior to the NE-10. The NE-11 is roughly the same dimensions and shape as the standard NE-10 Plasma Cartridge Rifle, because even with the new alloy, a cooling jacket is needed for this weapon due to the concentrated heat given off from its small barrel. However, it is lighter and can fire light or standard rounds and it is still a frighteningly effective assault weapon.

Weight: 12 lbs (5.4 kg).

Mega-Damage: 1D4x10 M.D. per single shot with a "Standard" Plasma Cartridge.

Rate of Fire: Single shots only; each shot counts as one melee attack.

Range: 1200 feet (366 m).

Payload: 20 shot magazine or 60 shot drum containing the NE-003PC "Standard" Plasma Cartridges, or a 40 round magazine or 120 shot drum firing the NE-001PC "Light" Plasma Cartridges, but the latter only does 3D6 M.D. per shot.

Cost: 60,000 credits. Each standard plasma cartridge costs credits (15 for light); an empty magazine costs 50 credits and an ammo drum 200 credits.

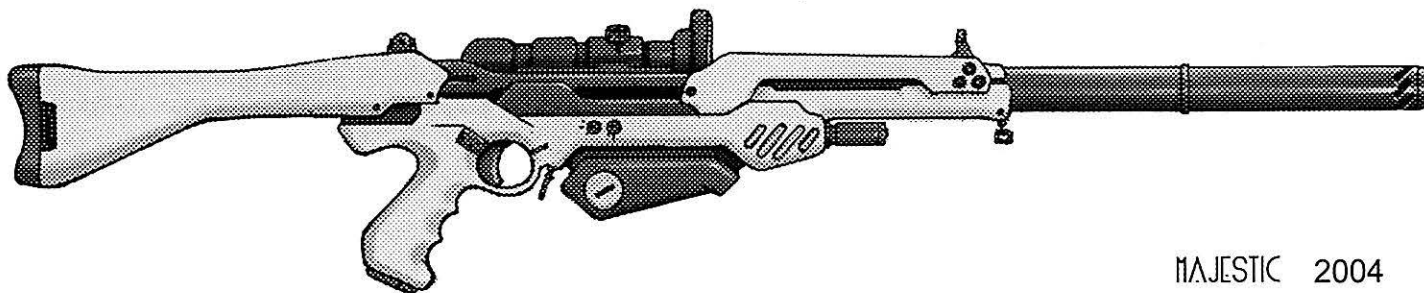

MAJESTIC 2004

NE-80 Slim-Line Lever Action Plasma Rifle

In the theme of the "Old West" – or is that the "New West" – the designers at Naruni Enterprises have whipped up a lever action plasma rifle using our Standard or Light Plasma Cartridges, but with greater range due to its lengthened Slim-Line barrel. The new NE-80 has the general styling of an old Winchester 40-82, but with Naruni's patented two-inch wide barrel. Each round of the NE-80 plasma rifle is moved into the breach by lever action, just like the classic weapon it was patterned after.

Weight: 12 lbs (5.4 kg).

Mega-Damage: 1D4x10 M.D. per single shot with a NE-003PC "Standard" Plasma Cartridge.

Rate of Fire: Single shots only. It only takes one action to lever a round into the chamber and fire for a expert gunmen such as Gunfighters, Gunslingers, Headhunters, Psi-Slingers, Sheriffs, and most types of Military Specialists, otherwise most other characters spend up two melee attacks/actions to lever and shoot a single round.

Range: 2,000 feet (610 m).

Payload: 8 round internal magazine when the NE-003PC "Standard" Plasma Cartridge is used, and must be hand loaded. Reloading the weapon takes one melee action per cartridge for most people, but a skilled rifleman or gunslinger (as noted under Rate of Fire) can load two per melee action. In the alternative, the weapon can hold 16 NE-001PC "light" cartridges but these rounds only do 3D6 M.D. per shot. A 24 round drum (standard rounds) or 48 round "light" cartridge drum can be mounted on the top of the rifle, but it ruins the classic "Western" motif.

Bonus: +1 to strike on an aimed shot.

Cost: 48,000 credits. Each "Standard Plasma Cartridge costs 30 credits (15 for light).

NE-295 "Maximum Threat" Slim-Line Assault Rifle

This little beauty is an over-and-under, two-barreled rifle that can be viewed as an upgrade of the NE-95 "Double Threat" Assault Rifle. It uses the new Slim-Line technology to make the weapon much lighter, jacketless, and with two pistol grips. The lower barrel still is a semi-automatic grenade launcher, but now uses a "banana" style magazine. The upper barrel fires the light Naruni plasma cartridges, but now has a rapid-fire three round burst capability.

The "banana" grenade magazine is located in the front, while the long cartridge magazine is in the back, in a "bull-pup" configuration. Each weapon now has its own trigger mechanism, with the grenade launcher fired by the forward pistol grip and the plasma cartridges fired from the rear pistol grip. The resulting weapon is still cumbersome for a human warrior, but is a very useful weapon for cyborgs, those clad in power armor, robots, and those with superhuman strength.

Weight: 20 lbs (9 kg).

Mega-Damage: Light Plasma Cartridge: 3D6 M.D. per single shot, 1D6x10 M.D. per controlled three round burst.

Grenade Launcher: Varies with grenade type. Typically fires the

NE-GF10 fragmentation (4D6 M.D.) or NE-GHE10 high explosive (6D6 M.D.) grenades.

Rate of Fire: Standard. The shooter can only operate one weapon system at a time.

Range: Light Plasma Cartridge: 2000 feet (610 m). Grenade Launcher: 1000 feet (305 m).

Payload: NE-001PC "Light" Plasma Cartridges: 60 round magazine or 120 round long magazine, or a 240 round ammo drum (worn on the hip or back) with a belt feed. Grenade Launcher: 20 round "banana" magazine.

Cost: 75,000 credits. Each light cartridge costs 15 credits, grenades cost 350 credits each.

NE-350 "Thumper" Plasma Cartridge Submachine-Gun

Got Coalition problems? Looking to protect your home? Getting ready to rumble? Then the new "Thumper" Plasma Cartridge Submachine-gun is the weapon of your dreams! Built on the reliable NE-300 frame, the Thumper uses a heavy banana style magazine and fires "Medium" Plasma Cartridges. The big difference between it and the NE-300 is a new and improved firing mechanism that conserves on rounds and a shorter barrel that provides greater control even when engaging in automatic fire. The weapon uses our new, patented, Thermo-Kinetic alloy technology, making it light and heat resistant, but even with the new alloy, a cooling jacket is needed because of the concentrated heat given off from the Thumper's faster firing mechanism. The NE-350's small barrel makes it ideal for close combat, urban combat, back alley fights, surgical strikes, and riot control against vehicles and barricades. It is also ideal for taking down armored troops and power armor, especially in places like the 'Burbs. Although some may consider the NE-350 a minor improvement on the NE-300, the more controlled burst firing pattern of the Thumper means much less wasted ammunition and greater control and accuracy. Perfect for use in urban environments.

Weight: 15 lbs (6.8 kg).

Mega-Damage: A single shot does 5D6 M.D.; a controlled three-round burst does 1D6x10 M.D.

Rate of Fire: A single shot or a controlled three-round burst counts as one melee attack.

Range: 600 feet (183 m).

Payload: 30 round "banana" magazine containing NE-002PC "Medium" Plasma Cartridges (provides 30 single shots or 10 bursts). A 60 round "big banana" clip is also available, but it makes the weapon a bit unbalanced and awkward to fire. (-2 to strike; characters with a Supernatural P.S. of 16, conventional P.S. of 24 or Bionic or Robotic P.S. of 20, or higher, can fire the gun using both hands for balance without penalty, and one-handed with a -1 penalty to strike.)

Bonus: Due to the NE-350's superior balance (with the standard banana clip) the weapon is +1 to strike on an aimed shot.

Cost: 38,000 credits. Each "Medium" Plasma Cartridge costs 20 credits.

Other Types of NE Weapons

Naruni Enterprises outfits some of the Megaverse's greatest mercenary companies, and from that experience we have learned one thing: Your average mercenary can never have too many weapons or weapon options available to him. If you give a merc a rifle, he wants a rifle with a grenade launcher. If you give a merc a rifle with a grenade launcher, he wants some other combat option, or a variation, etc. Many a mercenary has asked us to build him some outrageous combination of weapons. It is with that in mind that we offer the following line of different and versatile weapon systems. And remember, our NE-RV02 Ripper Vibro-Bayonet can be added to all rifles.

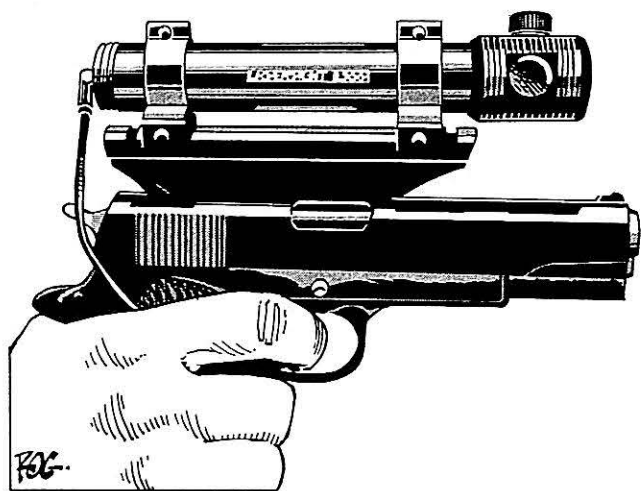

NE-Classic Earth Series Handguns

For those of you who prefer the classic look and feel of traditional Earth weapons or seek to trick authorities and adversaries into believing you are carrying an S.D.C. weapon instead of a Mega-Damage firearm, Naruni Enterprises presents the Classic Earth Series of handguns.

Note: Unless noted otherwise, ALL weapons in the Classic Earth Series have the same basic stats regardless of the weapon's actual design and appearance. Only the appearance varies.

Weight: 2-4 lbs (0.9 to 1.8 kg).

Mega-Damage: 3D6 M.D.

Rate of Fire: 6-14 rounds. Each shot counts as one melee attack/action.

Effective Range: 200 feet (61 m).

Payload: Revolvers: 6 round cylinder. Pistols: 14 round magazine. All fire the NE-001PC "Light" Plasma Cartridge; a more powerful round would melt the gun.

Cost: 12,000 credits for revolvers and 22,000 credits for pistols. Each "Light" Plasma Cartridge costs 15 credits.

Currently Available Models:

- .38 caliber Ruger Service (Police) Revolver
- .38 caliber "Snub-Nose" Revolver

* Magnum .44 caliber Revolver

* Western "Peacemaker" .45 caliber Revolver

Western Smith & Wesson .38 caliber Revolver

Western Remington .45 caliber Revolver

* Revolvers with an asterisk (*) use NE-002PC "Medium" Plasma Cartridges, inflicting 5D6 M.D. per shot, but only have a payload of four rounds and there is a 01-55% chance of the barrel melting if fired continuously for more than four melee rounds (one minute) without a three or four minute break after firing 8-12 shots. The barrel actually turns red after firing eight shots and burns to the touch (1D6 S.D.C.).

Beretta 9mm Automatic Pistol

Browning 9mm Automatic Pistol

Classic Mauser 9mm Automatic Pistol

Colt .45 Automatic Pistol

Colt 9mm Automatic Pistol

Glock 9mm Automatic Pistol

Walther 9mm Automatic Pistol

NE-77H Cyborg Shoulder Cannon

Also known as the "Big Punch"

For you full conversion cyborgs and power armored yahoos looking for a heavy-hitter that will vaporize the competition, look no further. The NE-77H is huge gun recommended for cyborgs, robots, power armor troops and beings with Supernatural Strength. (G.M. Note: Ordinary soldiers must have a conventional P.S. of 28, a Robotic or Bionic P.S. of 21, or a Supernatural P.S. of 18 or higher to effectively use this big, awkward weapon. Those with a P.S. of 22-27 are -2 to strike and take twice as long to reload. If P.S. is 15-21, the character is -5 to strike and if the P.S. is lower than that, the character can't even lift the gun all the way up and has trouble even if it is braced on something, -12 to strike. No penalty if mounted on a tripod or built into a weapon turret or other type of housing.)

The weapon is six feet (1.8 m) long from end to end and is usually mounted or hooked to a shoulder or back harness for additional support when being fired and as a means to stow the weapon on the back when not in use. This harness is reminiscent of the mechanism used by Glitter Boy. For you world travelers, it is essentially the same harness system used by the cyborgs of the Warlords of Russia. A normal human cannot fire the "Big Punch" except from the prone position or when mounted on a tripod or built into a vehicle or turret. It is one of the few particle beam weapons offered by any manufacturer and has superior damage and range. If you're looking for maximum firepower in a rifle, this weapon is a must.

Weight: 80 lbs (36 kg).

Mega-Damage: 1D6x10+12 M.D. per single blast.

Rate of Fire: Each shot counts as one melee attack/action.

Effective Range: 2000 feet (610 m); better than any P-Beam weapon offered by anyone on Earth!

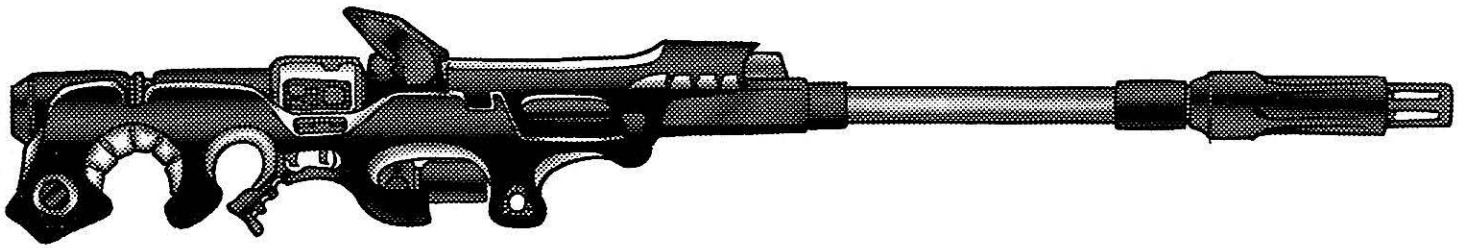

Payload: Cyborg hip generator pack (small) provides 30 blasts per hour and self-generates at a rate of one blast per every two minutes. A heavy generator backpack (about the size of a standard backpack for camping) offers 90 blasts per hour, but still self-generates only at a rate of one blast per every two minutes. A standard E-Clip can be inserted in the handle as a backup energy source providing 3 blasts per clip.

Cost: 90,000 credits. NE-EBG-X hip generator costs 250,000 credits, and the NE-EB-XX costs 750,000 credits, both are sold separately.

NE-78GL Super-Plasma Launcher

Also known as the "Two-Strike"

Offered for the first time anywhere, the NE-78GL is a state of the art anti-tank and armor weapon no mercenary company or freedom fighter can pass up. If you're looking for something that can knockout enemy armored vehicles and low flying aircraft in two or three shots, look no further. Rather than use conventional or micro-grenades, this gun uses our NE-005PC "Super-Heavy" Plasma Cartridge.

To keep the price affordable, the weapon does not use our Thermo-Kinetic technology, so the user must be aware of the weapon's limitations. The weapon can only fire two shots before the barrel turns red from the heat of the plasma rounds. Unless it is allowed to cool for six minutes, the next shot is likely (01-80% chance) to melt the barrel (costs 20,000 credits to replace). The odds of melting the barrel increase dramatically (01-90%) with the fourth shot and it is an absolute certainty with the fifth shot, destroying the entire weapon and inflicting 1D4x10 M.D. to the shooter as well. Despite its limitations, the NE-78GL has superior damage capabilities, excellent range and greater ease of conveyance than any grenade launcher on the market, and does more damage than most rockets or mini-missile launchers.

Weight: 22 lbs (10 kg).

Damage: 2D4x10 M.D. per single blast.

Rate of Fire: Each shot counts as one melee attack/action.

Effective Range: 2000 feet (610 m).

Payload: The weapon has a short "banana" magazine with 12 NE-005PC "Super-Heavy" Plasma Cartridges, but only two rounds can be fired safely, every six minutes.

Cost: 80,000 credits. The Plasma Cartridges cost 150 credits each or 13,000 for a box of 96.

NE-99 Rapid-Fire Assault Laser

Also known as the "Cyborg's Laser"

The ultimate anti-troop assault weapon for those of you who facing trouble from raiders, Monster Squads or folks in black armor, if you catch our drift. The NE-99 Assault Laser is the next step in small arms, a devastating heavy troop support weapon designed for use by humans when built into a weapon turret on a vehicle or fortification, or as a heavy weapon by augmented humans or beings with superhuman strength – ideal for cyborgs, robots (used by our very own Repo-Bots), power armor and those of you elite characters with Supernatural Strength. (G.M. Note: Ordinary soldiers must have a conventional P.S. of 28, a Robotic or Bionic P.S. of 21, or a Supernatural P.S. of 18 or higher to effectively use this big, awkward weapon. Those with a P.S. of 22-27 are -2 to strike and take twice as long to reload. If P.S. is 15-21, the character is -5 to strike and if the P.S. is lower than that, the character can't even lift the gun all the way up and has trouble even if it is braced on something, -12 to strike. No penalty if mounted on a tripod or built into a weapon turret or other type of housing.)

The NE-99 is often mounted on combat vehicles, jeeps and trucks, and used like a machine-gun on a tripod. The Rapid-Fire Assault Laser has devastating firepower, a large payload and is used like a machine-gun though it more resembles a mini-gun in its size and weight. Two NE-EB electrical batteries insert into the top housing of the weapon as its main power source, but a standard E-Clip can be inserted in the handle as a backup energy source. A full conversion cyborg and other extremely strong characters may hook the NE-99 to a Servo-Weapon Pack for even more power (described elsewhere in this section). Note that it takes a full melee round to remove and replace each of the two NE-EB batteries, but only one melee action to replace the E-Clip.

Weight: 100 lbs (45 kg) fully loaded.

Mega-Damage: The NE-99 Rapid-Fire Assault Laser has a variety of settings.

Setting One: 2D6 M.D. per single shot. +2 to strike if the shooter has the W.P. Heavy Energy Weapons skill (no bonus without the W.P.).

Setting Two: 5D6 M.D. per short burst. Counts as one melee attack, but uses up four rapid-fire blasts. +1 to strike if the shooter has the W.P. Heavy Energy Weapons skill.

Setting Three: 1D6x10 M.D. per medium burst. Fires 8 shots and counts as two of the shooter's melee attacks. No bonus to strike even with W.P.

NE-97 “Triple Threat” Laser Rifle

Setting Four: 2D6x10 M.D. per long burst. Fires 16 blasts and counts as two of the shooter’s melee attacks. No bonus to strike even with W.P. The attack may be directed at one target (takes all damage) or at several in a spray shooting attack, inflicting 3D6 M.D. to 1D6+1 targets/items. No bonuses to strike and anyone struck in a spray attack must be in the line of fire and is a random victim. Cannot aim at any one or two specific targets with this attack; basically the same as shooting wild by spraying or peppering an area or line of targets in general rather than at one specific target.

Setting Five: 4D6x10 M.D. per extended burst. Uses 32 blasts and counts as three of the shooter’s melee attacks. May be directed at one target or at several as a spray shooting attack, inflicting 3D6 M.D. to 2D6+2 targets/items in the line of the spray. No bonuses to strike and anyone struck in a spray attack must be in the line of fire and is a random victim; cannot aim with this attack; basically the same as shooting wild by spraying or peppering an area or line of targets in general rather than at one specific target.

Rate of Fire: Standard Modern Weapon Proficiency combat.

Range: 4,000 feet (1219 m).

Payload: The NE-99 Rapid-Fire Assault Laser holds two NE-EB electrical batteries, with 120 shots per battery for a total standard payload of 240 shots (240 single blasts, 60 short bursts, 30 medium bursts, 15 long bursts, or 7 extended bursts and one long burst). The standard E-Clip provides another 20 blasts usually reserved for single shots or short bursts.

Cost: 150,000 credits. NE-EB electrical batteries cost 100,000 credits each and are sold separately.

A variation on the NE-95, this is a versatile weapon we recommend to Headhunters, Juicers, Crazies, cyborgs, power armored mercenaries and other adventurers with augmented strength. The NE-97 is an over-and-under, two-barreled rifle with three firing options. The lower barrel is a semi-automatic grenade launcher with a drum magazine. The upper barrel is a variable laser rifle with two damage settings, one for single shot for precision shooting and sniping, the other a rapid-fire pulse action. The drum magazine is located in the front, while the E-Clip is in the back in a “bull-pup” configuration. Both weapon systems use the same trigger mechanism; switching from one to the other is a matter of pressing a button on the handle of the rifle. The resulting weapon is heavy and cumbersome for humanoid soldiers (-1 to strike when aimed using two hands, -3 to strike when used one-handed unless the character has a conventional P.S. of 24 or an augmented P.S. of 18 or greater), but just right for people with augmented strength.

The variable frequency capability allows the shooter to change the laser to 10 different laser frequencies by touch or voice command. An internal computer makes the desired change. Designed to overcome laser resistant armor, like that of the famous Glitter Boy. Enemies of Free Quebec take note!

Weight: 25 lbs (11.3 kg)

Mega-Damage: Laser: 3D6 M.D. per single shot; triple blast pulse 6D6+6 M.D.

Grenade Launcher: Varies with grenade. Typically fires NE-10G fragmentation (4D6 M.D.) or high explosive (6D6 M.D.) grenades.

Rate of Fire: Whether a single shot or short burst/triple pulse, either count as one melee attack.

Effective Range: Laser: 2000 feet (610 m). Grenade Launcher: 1000 feet (305 m).

Payload: Laser: 21 single shots or 7 bursts per standard E-Clip; 50% more with a long, FSE-Clip.

Cost: 52,000 credits for the gun; ammunition and energy clips sold separately.

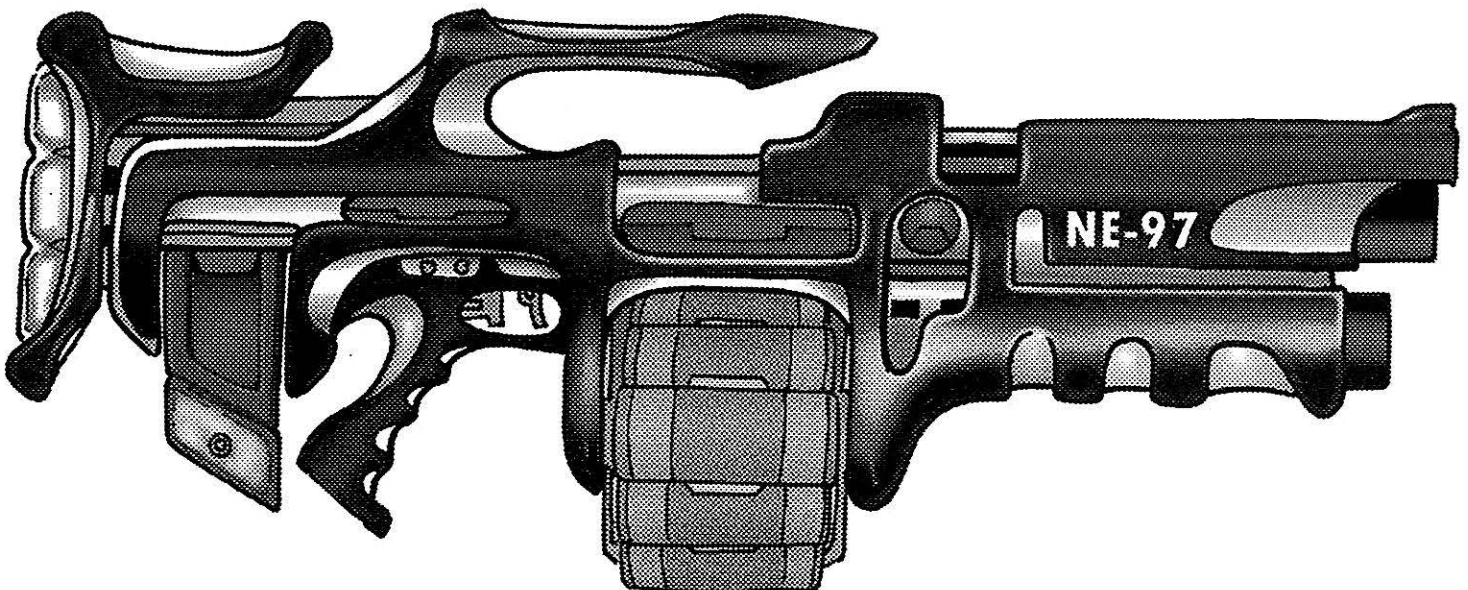

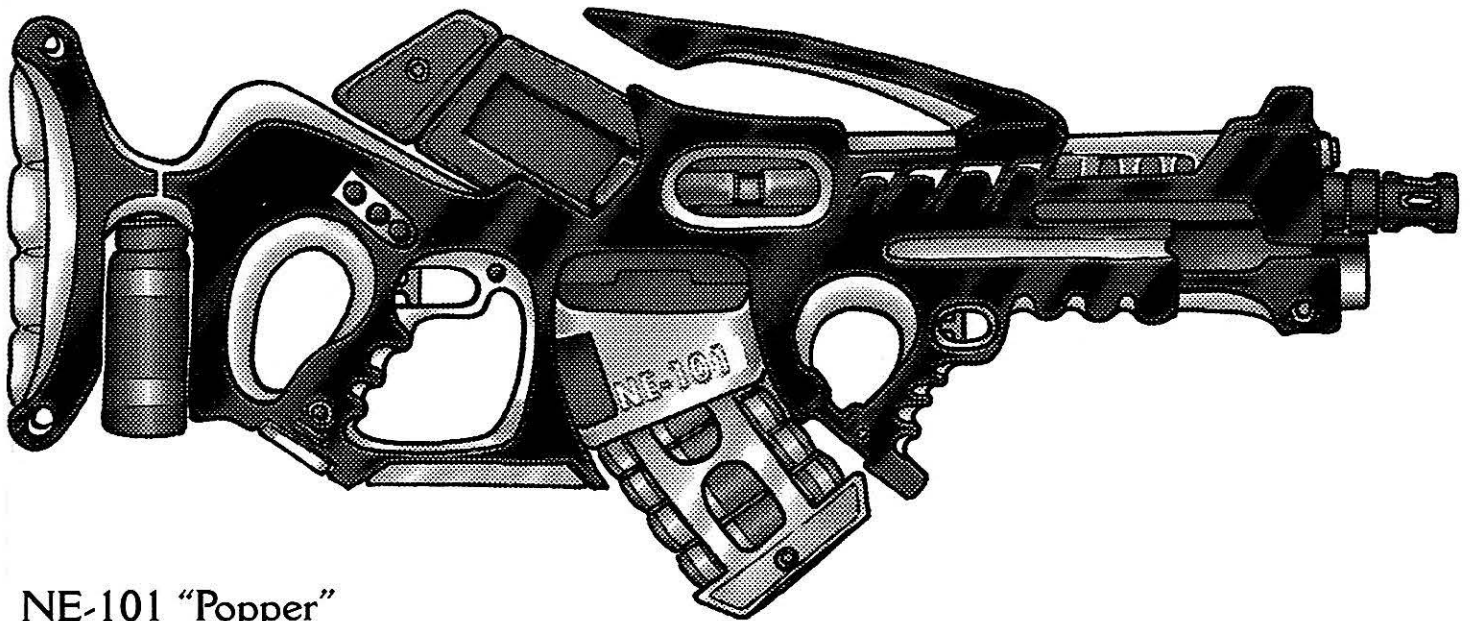

NE-101 "Popper" Mercenary Multi-Rifle

This is a large, three-barreled weapon, with two pistol grips and a stock, which is designed to fire a variety of ordnance. The main barrel is a Slim-Line Plasma Cartridge rifle. The thinner top barrel is a long-range laser for sniping and precision work, and the short barrel at the bottom fires NE-G10 type grenades. The package is completed by the inclusion of the NE-RV02 Ripper Vibro-Bayonet.

The "banana" grenade magazine is located in the front, while the long cartridge magazine is in the back, in a "bull-pup" configuration, and the E-Clip for the sniping laser is inserted in a slot in the stock. Each weapon has its own trigger mechanism, with the grenade launcher and laser fired by the forward pistol grip (two triggers) and the plasma cartridges are fired from the rear pistol grip. Infantry soldiers have been known to think twice when faced with this intimidating three-barreled gun.

Weight: 25 lbs (11.25 kg).

Mega-Damage: 1) Sniping Laser: has three settings, 1D6 M.D., 2D6 M.D. or 3D6 M.D. (Sniping Laser is +1 to strike on aimed shot only).

2) 5D6 M.D. from a single "Medium" Plasma Cartridge or 1D6x10 M.D. from a controlled three round burst.

3) Grenade Launcher: Varies with grenade type. Typically fires the NE-GF10 fragmentation (4D6 M.D.) or NE-GHE10 high explosive (6D6 M.D.) grenades.

4) NE-RV02 Ripper Vibro-Bayonet does 3D4 M.D. in hand to hand combat only.

Rate of Fire: Each energy blast, burst or grenade shot counts as one melee attack/action. Only one weapon system can be used at a time.

Range: Laser: 2000 feet (610 m); Plasma Cartridge: 1200 feet (366 m); Grenade Launcher: 1000 feet (305 m); and the Ripper Vibro-Bayonet is good only in hand to hand combat.

Payload: NE-002PC "Medium" Plasma Cartridges: 30 round long magazine. Grenade Launcher: 20 round banana magazine, and the sniping laser can use either a standard E-Clip good for 20 shots, or a long FSE-Clip good for 30 shots.

Cost: 75,000 credits; ammunition and energy clips sold separately.

NE-102 "SpitFire" Mercenary Multi-Rifle

Mercenaries face all kinds of human and inhuman foes. When facing an enemy vulnerable to fire, the SpitFire is the rifle you'll want. The NE-102 is a combination assault rifle for conventional foes, flamethrower and plasma ejector all rolled into one. The NE-102 builds on the three barrel platform of the NE-101, with the large barrel shooting mini-balls or bolts of flaming plasma, the narrow barrel firing Light Plasma Cartridges and the short barrel being the flamethrower. An additional E-Clip in the handles of both the pistol grips can provide enough energy to be a threat (30 plasma bolts and 10 blasts of fire), but for real punch, we suggest the hip power pack (60 plasma bolts, 20 blasts of fire and regenerates at a rate of 30 shots per every two minutes).

Weight: 20 lbs (9 kg).

Mega-Damage: 1) Light Plasma Rounds: 3D6 M.D. per single round or 6D6 M.D. per three round burst. 2) Plasma Bolts: 4D6 M.D. per blast. 3) Flamethrower: 3D6 M.D. per blast of fire.

Rate of Fire: Each blast, regardless of type, counts as one melee attack.

Range: 1) Plasma Cartridge: 1200 feet (366 m). 2) Plasma Bolts: 1600 feet (487.6 m). 3) Flamethrower blast: 50 or 100 feet (15.2 or 30.5 m; two settings).

Payload: 1) NE-001PC "Light" Plasma Cartridges: 48 round long magazine (48 shots or 16 bursts). 2) Plasma Bolts: 30. 3) Flamethrower blasts: 10. The latter two are doubled if the light, hip-pack, rechargeable generator is used, quadruple the number of blasts if the backpack generator is used; same as the NE-77H Cyborg's Shoulder Cannon ("Big Punch").

Cost: 50,000 credits for the gun. E-Clip costs are standard (typically 5000 credits each), and "Light" Plasma Cartridges cost 15 credits each. NE-EBG-X hip generator costs 250,000 credits, and the NE-EB-XX (backpack) costs 750,000 credits, both are sold separately (see the "Big Punch" Shoulder Cannon for details).

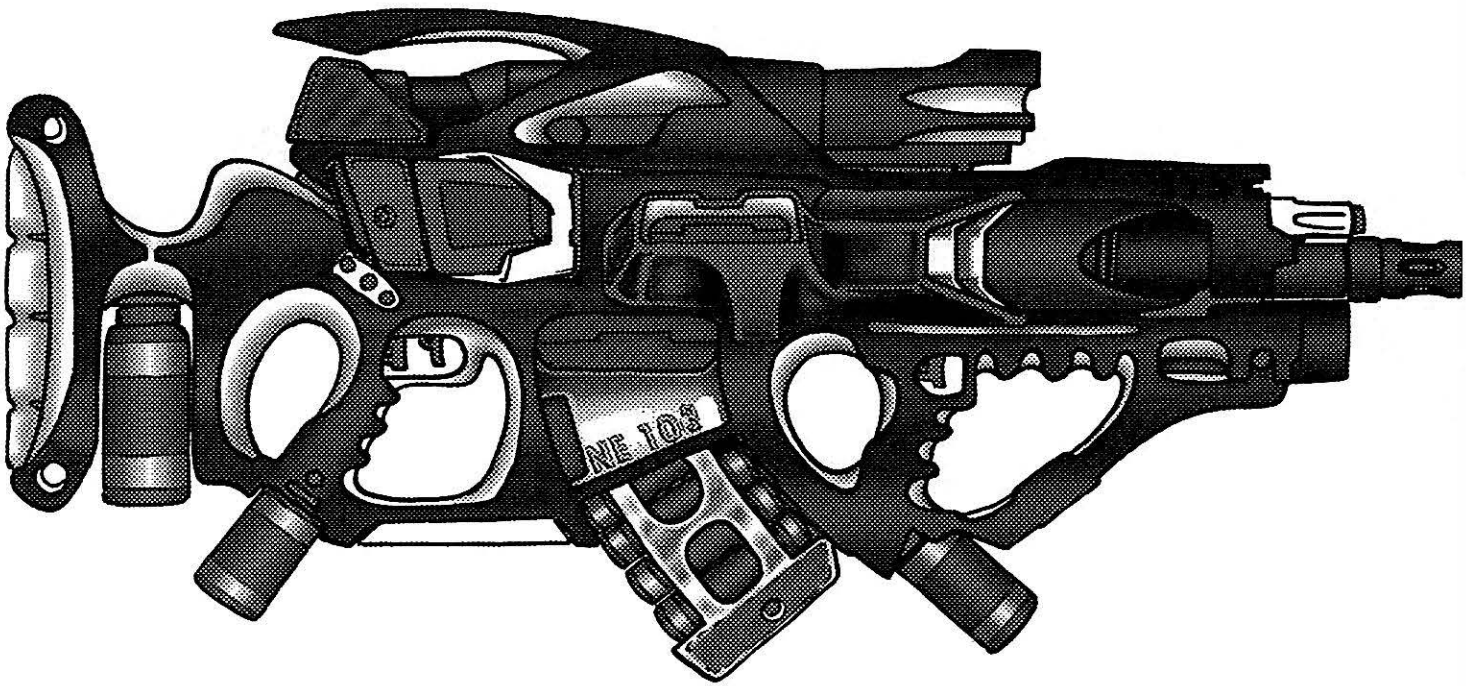

NE-103 Silverfire Mercenary Multi-Rifle

The NE-103 is another specialized weapon designed with mercenaries, adventurers and demon slayers in mind. It is a combination assault rifle able to shoot silver coated S.D.C. rounds for slaying vampires and other beings vulnerable to silver, a light laser, and flamethrower. The NE-103 builds on the three barrel platform of the NE-101, with the large barrel firing large caliber S.D.C. rounds, the narrow barrel being the light laser and the short barrel being the flamethrower. The E-Clip goes into one handle and the ammo clip in the other. Comes standard with a telescopic scope sight (x10) built into it (bringing the sniping laser up to a +2 to strike) and a detachable NE-RV02 Ripper Vibro-Bayonet.

Weight: 16 lbs (7.2 kg).

Mega-Damage: 1) S.D.C. bullets: 5D6 S.D.C. per round or 1D6x10 S.D.C. per three round short burst. 2) Light laser: 2D6 M.D. per blast; single shot only, but suitable for sniping. 3) Flamethrower: 2D6 M.D. per blast of fire. 4) Ripper Vibro-Bayonet: 3D4 M.D.

Rate of Fire: Each blast, regardless of type, counts as one melee attack.

Range: 1) S.D.C. rounds: 2400 feet (731.5 m). 2) Laser: 2000 feet (610 m) 3) Flamethrower blast: 50 or 100 feet (15.2 or 30.5 m; two settings).

Payload: 1) 100 S.D.C. rounds (most conventional rifle rounds of varying size will work in this rifle). 2) Light Laser: 24 shots per standard E-Clip, 368 from a long-FSE-Clip. 3) Flamethrower blasts: 8. The latter two are doubled if the light, hip-pack, rechargeable generator is used, quadruple the number of blasts if the backpack generator is used; same as the NE-77H Cyborg's Shoulder Cannon ("Big Punch").

Cost: 42,000 credits for the gun. 400 credits for a box of 144 silver coated rounds (half that for conventional ammo). E-Clip costs are standard (typically 5000 credits each). NE-EBG-X hip

generator costs 250,000 credits, and the NE-EB-XX (backpack) costs 750,000 credits, both are sold separately (see the "Big Punch" Shoulder Cannon for details).

NE-104 Missile Mercenary Multi-Rifle

And now for something completely different: A combination rocket launcher, grenade launcher and laser. Includes a telescopic scope sight (x10) built into it (bringing the sniping laser up to a +1 to strike). The trigger arrangement is such that the rocket launcher is fired by the forward pistol grip (the weapon has two triggers and handles) and the grenade launcher and laser fired from the closest pistol grip; a switch changes which mode of firing is desired, laser or launcher. To make the weapon more effective, the mini-missile launch tube is four feet (1.2 m) long, with the grenade launcher slightly shorter. The large size, weight and the awkwardness of the weapon demands that it is used as a two-handed device or even a two-man device, with one offering his shoulder as a brace and the other doing the shooting. (Individuals with a conventional P.S. of less than 20 are -3 to strike and take twice as long to reload. Characters with greater strength can use it with both hands or attached to a shoulder harness without penalty; -2 to strike if used one-handed even if the character is very strong. Note: Headhunters and Brodkil love this weapon, and it can be used by individuals up to 10 feet/3 m tall.)

Weight: 50 lbs (22.5 kg).

Mega-Damage: 1) Laser: 3D6 M.D. 2) Grenade Launcher: Varies with grenade type. Typically fires one NE-GF10 fragmentation (4D6 M.D.) or NE-GHE10 high explosive (6D6

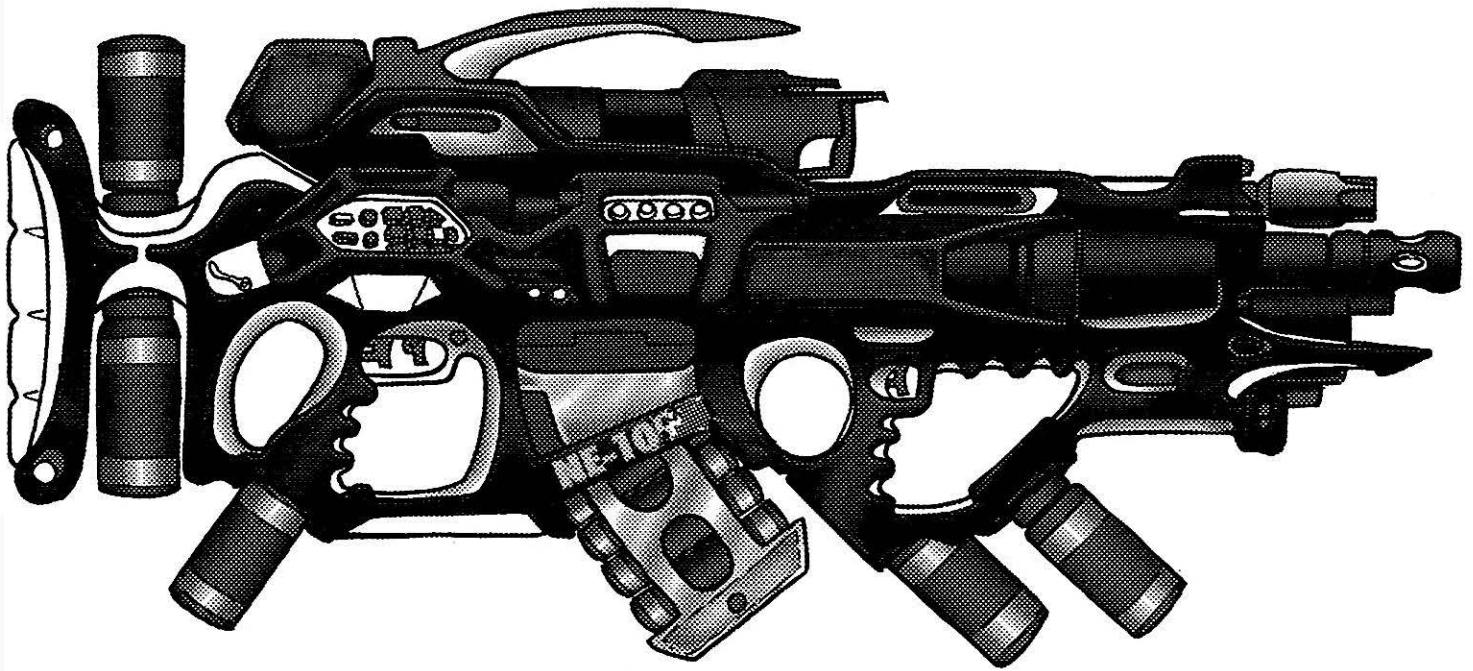

M.D.) grenade. 3) Mini-Missiles: Varies with the mini-missile type but typically armor-piercing, doing 1D4x10 M.D. or plasma, doing 1D6x10 M.D. 4) Vibro-Bayonet: 3D4 M.D.

Rate of Fire: Standard. The shooter normally only operates one weapon system at a time, but if the shooter takes a -2 to strike penalty, he may fire the plasma cartridge rifle and particle beam together, doing a combined total damage of 3D4x10 M.D. on an aimed shot only, but no bursts or sprays are possible when combined and remember that the particle beam has limited range.

Range: Laser: 2000 feet (610 m), Grenade Launcher: 1000 feet (305 m), Mini-Missile: Up to one mile (1.6 km), and the Ripper

Vibro-Bayonet is only good in hand to hand combat (-3 to strike if P.S. is less than 20).

Payload: Laser: 20 blasts per standard E-Clip (30 with a long-Clip). Grenade Launcher: 20 round "banana" magazine. Mini-Missiles: One mini-missile is held in the firing tube, but additional ones can be loaded by hand (counts as two melee actions). Mini-Missiles come in carrying cases of six (18 lbs/8 kg), 12 (36 lbs/16.2 kg), and 24 mini-missiles (72 lbs/32.4 kg).

Cost: 64,000 credits. Grenades cost 300 or 350 each, and mini-missiles cost 4,000 credits each.

NE-105 Super-Rail Gun

This is the grand-daddy of them all, a rail gun with a "lightning" feature which is a high voltage, electric arc zapper. Great for full conversion cyborgs, power armored troops and super strong individuals looking for a heavy rail gun with something extra.

Weight: 120 lbs (54 kg) for the gun, plus NE hip pack generator (10 lbs/4.5 kg) and ammo drum (100 lbs/45 kg, typically mounted on the back or shoulder, though a shoulder mounting creates a blind spot; -2 to parry, -3 to dodge and -3 to roll with impact).

Mega-Damage: 1) Rail Gun: A short burst of 10 rounds does 5D6 damage, and a heavy burst of 20 rounds does 1D6x10 M.D.

2) Electric Arc: 2D6 M.D., double damage to unshielded electronic devices (computers, cameras, radios, etc.). Additionally,

humans and most humanoids have to make a save of 14 or higher (with any possible bonus to P.E.) or lose initiative and two melee attacks/actions for one melee round. Beings who are immune to electricity will take no damage.

Rate of Fire: Each electric blast or rail gun burst counts as one melee attack.

Range: Rail Gun: 4000 feet (1219 m). Electric Arc: 200 feet (61 m).

Payload: Rail Gun: 3000 round ammo drum (300 short bursts or 150 heavy bursts). Electrical Arc: 90 per hip generator, and regenerates at a rate of 30 per hour.

Cost: 370,000 credits including gun, ammo drum, hip generator and multi-optics sight.

NE-700 Vulcan Plasma Cartridge Mini-Gun

A mini-gun style heavy weapon, the NE-700 is designed to fire NE-003PC "Standard" Plasma Cartridges at very high cyclic rates, allowing a single trooper to lay down devastating suppression fire or to destroy power armor, robots or vehicles with its firepower. The Vulcan mini-gun is one of the heaviest of the man-portable weapons, but like the other heavy weapons, in order to carry and fire it the user must have a conventional P.S. 25 or higher. Best suited in two-man teams or may be built into weapon turrets on a vehicle or fortification. Ideal for cyborgs, robots, power armor and those of you elite characters with Supernatural Strength. (G.M. Note: Ordinary soldiers must have a conventional P.S. of 26, a Robotic or Bionic P.S. of 21, or a Supernatural P.S. of 18 or higher to effectively use this big weapon. Those with a conventional P.S. of 20-25 are -2 to strike and take twice as long to reload. If P.S. is less than 20, the character is -5 to strike and if the P.S. is lower than that, the character can't even lift the gun to shoot it, and has trouble aiming even if it

is braced on something or by another person, -12 to strike. No penalty if mounted on a tripod or built into a weapon turret or other type of housing.)

Weight: 140 lbs (63 kg), add another 60 lbs (27 kg) for the ammo drum.

Mega-Damage: A single shot does 1D4x10 M.D.; a controlled six round burst does 4D6x10 M.D.

Rate of Fire: A single shot or a controlled six round burst counts as one melee attack.

Range: 1200 feet (366 m).

Payload: The NE-700 can use either a 30 shot "banana" magazine of the NE-003PC "Standard" Plasma Cartridges or a 150 round drum fed by a disintegrating ammo belt (25 bursts).

Cost: 570,000 credits and limited availability. Each Standard cartridge costs 30 credits.

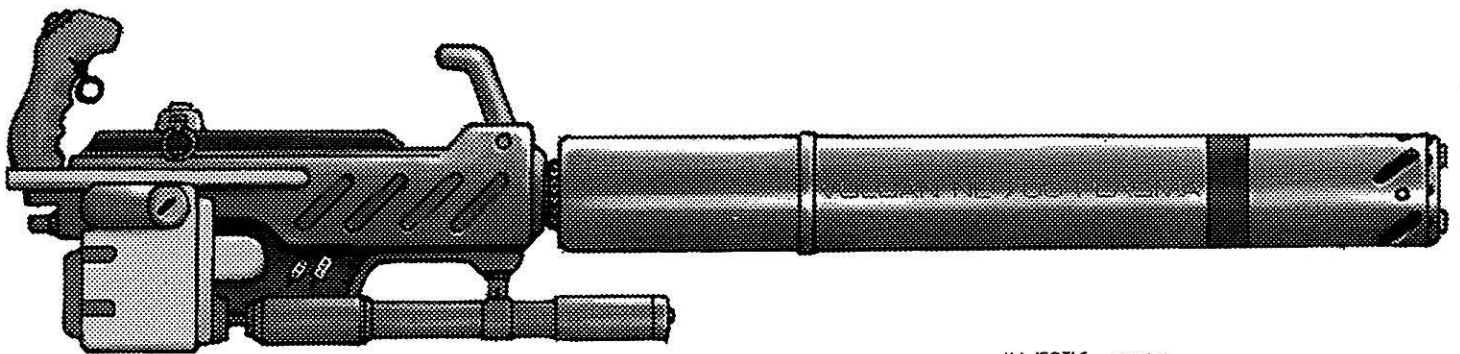

MAJESTIC 2004

New! Thermo-Kinetic Armor

By Carmen Bellaire

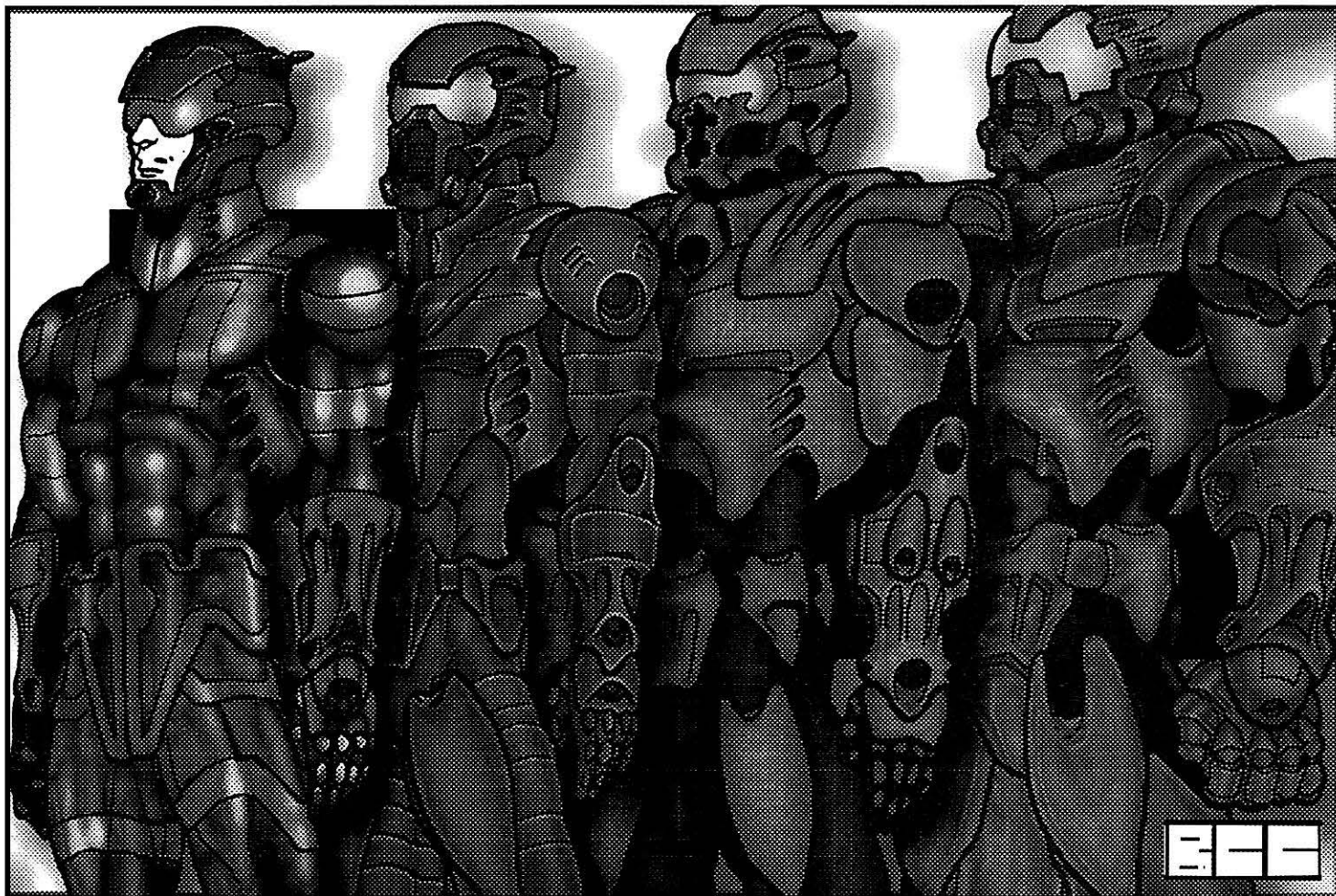

Many customers insist that our greatest achievement in recent cutting edge technology is our unprecedented advances in Thermo-Kinetic Armor. This new material converts a portion of all kinetic and thermal attacks into harmless energy, and greatly reducing the effectiveness of many attacks against the armor, and increasing its wearer's rate of survival as well as the length of the armor's operational life. Thermo-Kinetic Armor can give you quite an edge on the battlefield. Unlike many other high-tech battle armor suits, such as laser reflective armor, Thermo-Kinetic Armor cannot be overcome by simple technology like variable frequency lasers. Best of all, Thermo-Kinetic Armor reduces damage from fire and heat, including magical flame, plasma bolts and flamethrowers, as well as physical/kinetic impacts from explosions, rail gun rounds, missiles, grenades, vehicular impact, and falls (half damage). This makes our Thermo-Kinetic Armor absolutely unlike any on Earth. For maximum combat protection, you want Thermo-Kinetic Armor.

Standard properties of NE fully sealed environmental Thermo-Kinetic body armor:

- Complete environmental battle armor suitable for use in all hostile environments, including space.
- Masks infrared and thermal emissions, making the wearer's heat invisible to infrared and thermal optics! There's only a 01-25% chance of showing up on thermal systems, and even then the reading/image will seem unusual/unclear. **Note:** This feature alone raises the cost of the armor, and the damage resistance (see the next two features) increases the cost even more compared to conventional Earth armor, but worth every credit.
- Insulated, high temperature resistant shielding for up to 500 degrees centigrade. Normal fires do 5% of their normal damage and only when exposed to it for more than a few minutes. Mega-Damage fire, heat, plasma and magic fire does half damage. (M.D. cold does full damage.)
- Kinetic energy dampening and cushioning system. Explosions, high impact, falls, and projectile weapons (arrows, bullets, rail gun rounds, grenades, missiles, etc.) do half damage. S.D.C. punches, kicks, and weapons do no damage. **Note:** Low speed kinetic impact from punches at Bionic, Robotic and Su-

pernatural Strength levels do full damage. Laser weapons, ion blasters, electricity, particle beam weapons and M.D. cold attacks also inflict full damage.

- Computer controlled life support, including internal cooling and temperature control.
- Artificial air circulation system, gas filtration, humidifier and radiation shielded.
- Computer controlled, independent oxygen supply and purge system that automatically engages in low oxygen or contaminated air environments. Ten hour oxygen supply.
- Maximum underwater depth tolerance of 2,000 feet (610 m).
- Helmet face plate is removable, with a polarized and light sensitive/adjusting tinted visor.
- Built-in loudspeaker; 80 decibels.
- Directional, medium-range radio built into the helmet. Range is 20 miles (32 km), double with booster and/or transmitter towers.
- Built-in language translator, includes American, Dragonese, Euro, French, Spanish, Techno-Can, plus two others of choice.
- Concealed Mini-Comp: A multi-purpose miniature computer and display is built into the left wrist that will indicate system errors within the armor, including damage levels, oxygen supply, depth gauge, time, date, and directional compass.
- Forearm Flashlight: Built into the armor above the right wrist is a small flashlight (range is 30 feet/9.1 m) that can be activated by a tiny wrist button or voice command.
- Strategically placed magnetic strip clamps for holding hand grenades, tools, and small weapons without the need for additional belts or pouches.
- Standard attachment points on back for an NE-01BP Backpack, NE-02S Servo Harness, NE-03DP Diving Pack, NE-05GP Grav Pack, NE-07JP Jet Pack, NE-09SP Survival Pack or the much sought after NE-0XWP Servo-Weapon Pack.
- Naruni Thermo-Kinetic Armor is available in a variety of stylish designs and comes in the colors of burnished silver, burnished gold, cobalt blue (very dark), matte black, white and forest or desert camouflage patterns.

NE-CS1 Cermalyte Black Nightsuit

By Patrick Nowak

There are many times during combat operations where Mega-Damage body armor is too heavy, bulky and restrictive – such as when a character must scale the side of a fifteen-story building, or infiltrate a CS base. For these instances, most mercenaries, spies, thieves and assassins have traditionally used a black jumpsuit and mask made from durable, rip-resistant S.D.C. materials. Naruni Enterprises offers a new alternative, a sleek, black, snug-fitting body suit made from a patented, lightweight, Mega-Damage fabric that NE calls Cermalyte. The suit itself provides the wearer with limited M.D.C. protection (30 M.D.C.), but weighs no more than an average set of clothing and allows the individual to move with full mobility. Even the Thermo-Kinetic padded shoulder, forearms and chest plates only add a few extra pounds that are hardly noticed. Additionally, Cermalyte is a black, non-reflective material that makes hiding at night or in shadows easier, plus the soles of the Nightsuit are made of a

thick, sound absorbent material that virtually assures stealthy movement (+5% to Prowl skill). Can be worn under other clothing, suits, jackets, coats, and other accessories, even power armor.

The Nightsuit is a favorite of assassins, spies, master thieves and members of special forces. If you are involved in or planning covert and clandestine operations, the Nightsuit may be exactly what you need.

Class: Non-Environmental Cermalyte Body Armor.

Size: Human equivalent.

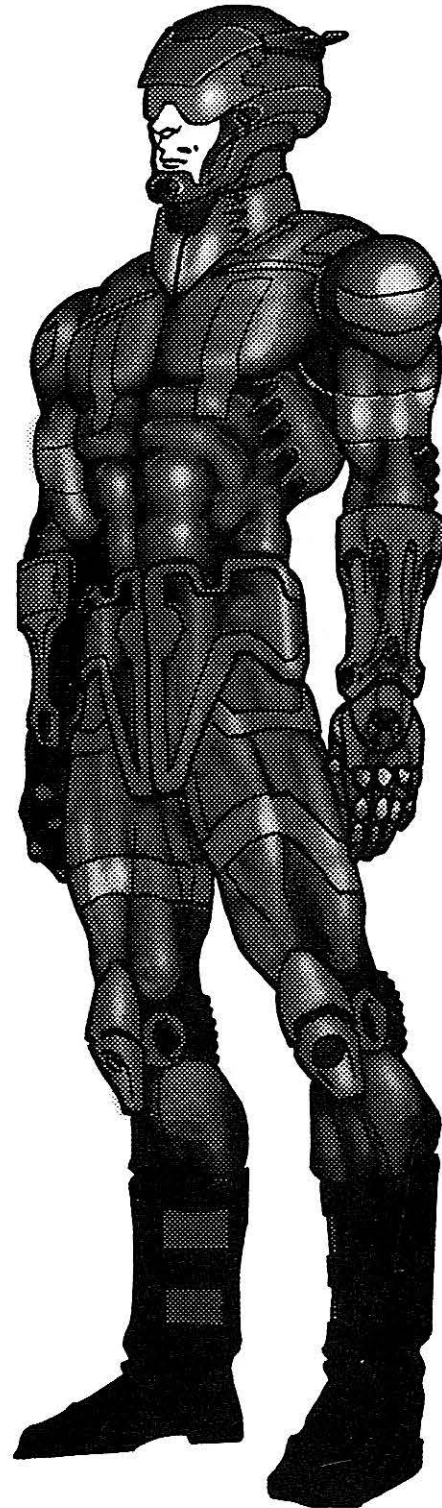

Weight: 4 pounds (1.8 kg).

Mobility: Excellent; no penalties on physical skills or movement.

Color: Comes standard in black.

Bonuses: The black color, cushioned soles of the boots, non-reflective and sound-absorbing material give the wearer a +5% bonus to Prowl.

M.D.C. by Location:

Head – 14 (Optional Helmet adds 30 M.D.C. but costs an extra 6,000 credits)

Arms – 14 each

Legs – 14 each

Main Body – 28

Note: Does not have the standard environmental body armor properties.

Cost: 12,000 credits (26,000 on the Black Market; hard to find).

NE-BA-20 “Stalker”

Partial Body Armor

This partial armor is light, providing increased physical protection without sacrificing mobility and stealth. The Stalker contains an advanced version of the sound dampening system found in the heavier armors and is excellent for light combat, urban environments, and missions of sabotage, assassination and espionage.

Class: Non-Environmental Thermo-Kinetic Body Armor.

Size: Human equivalent.

Weight: Light: 7 pounds (3.1 kg).

Mobility: Excellent; no penalties on physical skills or movement.

Color: Comes standard in black, costs a 10% premium for other colors.

M.D.C. by Location:

Head/Helmet – 30 (open faced helmet; will need air filter)

Arms – 18 each

Legs – 28 each

Main Body – 45

Special Features: Does not have the standard environmental body armor properties, but is resistant to heat, fire, explosions and bullet impact, all of which do 25% less damage than usual. Comes standard with a directional, short-range radio built into the helmet (5 miles/8 km range), and a pair of forearm mounted, retractable Vibro-Blades (one in each forearm): 2D4 M.D. for hand to hand combat.

Cost: 25,000 credits (40,000 on the Black Market; hard to find).

NE-BA-26 Special Body Armor

By Patrick Nowak

The NE-BA-26 Special is a suit of full environmental body armor with a modular design for quick changes, modifications, and numerous upgrades, augmentations and supplementary systems that can be quickly installed in the basic armor on a plug and play basis. As additional components are added to the basic model the price increases dramatically, to the point where if most

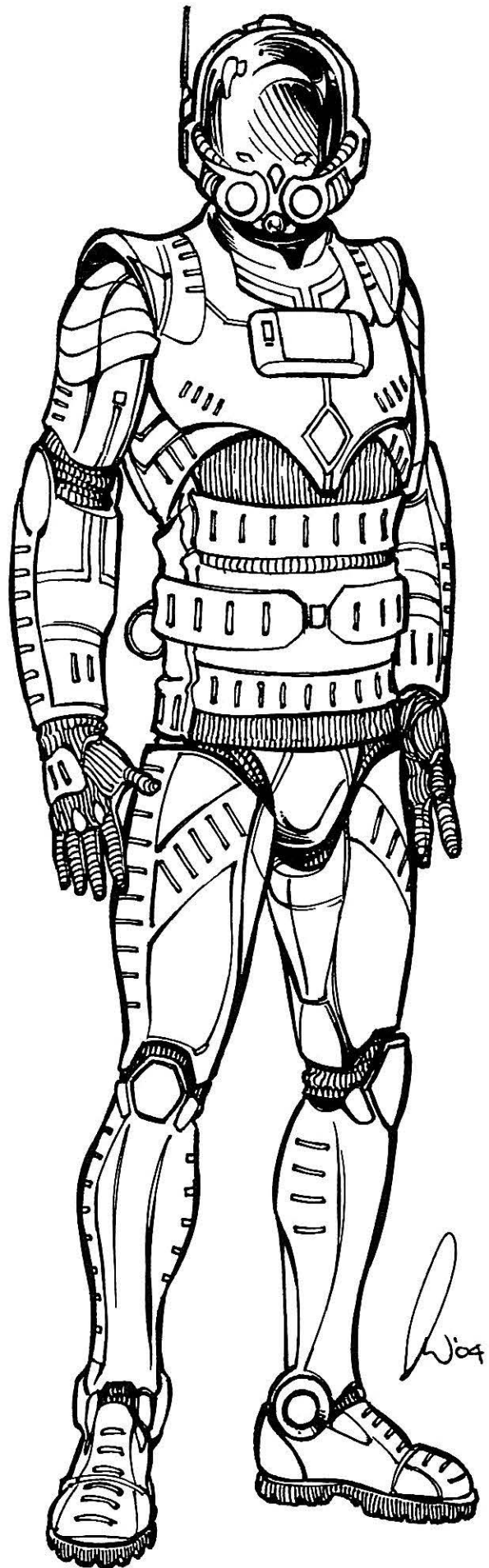

of the additional features are selected the armor costs about the same as many light power armor suits. Naruni Enterprises will install all of the desired extra systems at the time of purchase, for no extra cost. Upgrades can be bought at any time thereafter but in addition to the cost of the system, Naruni Enterprises charges 500-1000 credits as an installation fee.

It is a favorite among adventurers, Operators, Headhunters and Mercenaries. The advanced systems are reserved for specialized troops like officers, specialists, sappers, signalers or heavy weapons soldiers. Mercenary companies will buy the basic armor suit and allow individual members of the team to purchase whatever "extras" they need or want out of their own pocket or as a reward for outstanding service. Features 1, 2, 4, 6 and 7 are among the most popular for combat troops.

Class: NE Modular Full Environmental Body Armor.

Size: Human equivalent. Giant-sizes accommodating customers up to 10 feet (3 m) tall are sometimes available at double the usual cost (add 50 M.D.C. to the main body and 10 M.D.C. to all other locations).

Weight: 21 lbs (9.5 kg) for human equivalent, 35 lbs (15.8 kg) for giant-size.

Mobility: Fair mobility, -10% to Prowl, Climb, Swim, or perform Acrobatics and similar physical skills.

M.D.C. by Location:

- Head/Helmet – 50
- Arms – 40 each
- Legs – 50 each
- Main Body – 90

Market Price: 35,000 credits for non-Thermo-Kinetic Armor (excellent availability for the basic, no-frills suit and typical Modular Features) or 100,000 credits for Thermo-Kinetic Armor (fair to good availability). The cost for a suit with all of the upgrades listed below would be well over 200,000 credits.

Additional Modular Features & Upgrades (and their cost):

1. HUD Visor: A Heads Up Display that can project data, charts, topographical maps, orders and mission information, or transmissions on the visor of the helmet for the wearer to see. As many as six different HUD viewing sections/images can be projected without impairing the vision of the wearer. Cost: 2500 credits.

2. Basic Weapons Package: A retractable energy blade (3D6 M.D.) in the right forearm, garrote strangle cord in the left wrist (4D6 S.D.C. plus P.S. damage), plasma flamethrower (5D6 M.D. to a 20 foot/6.1 m area, 200 foot/61 m range, 15 shot payload per standard E-clip), and a utility finger laser (2D6 M.D. per shot, 1000 foot/305 m range, 20 shot payload per standard E-Clip). The flamethrower and finger laser use standard Earth style E-Clips. Cost: 28,000 credits.

3. Deluxe Weapons Package: Twin retractable energy blades in each forearm (4D6 M.D.), plasma-encased garrote strangle cord in the left wrist (5D6 M.D. per melee round), particle beam blaster (1D4x10 M.D. per shot, 2000 foot/610 m range, 10 shot payload per standard E-Clip), and NE-28R micro-missile wrist launcher (6D6 M.D. to a 3 foot/0.9 m area, one mile/1.6 km range, two missile payload). Not generally available outside of the Three Galaxies. Cost: 60,000 credits.

4. Robotic Exoskeleton: Has an internal, heavy-duty, reinforced robotic exoskeleton to boost the wearer's own physical abilities. Provides the following bonuses while wearing the suit: a robotic P.S. of 25, +4 to P.P., +20 to Spd., +10 feet (3 m) to leaps, +10% to Climb skill, and reduce the rate of fatigue by 75%. Robotic Strength enables the wearer to inflict Mega-Damage with hand to hand attacks. Inflicts 6D6 S.D.C. on a restrained punch, 1D4 M.D. for a regular punch or kick and 2D4 M.D. on a power punch or jump kick. Note regular punch damage is added to M.D. attacks with melee weapons. Cost: 50,000 credits.

5. Built-In N-F20A Force Field: Integrated into the suit is a standard N-F20A force field that provides the wearer with a 75 M.D.C. protection field. This field engages at a voice command from the wearer. Cost: 62,000 credits.

6. Laser Distancer & Targeting: As a distancing device it measures and indicates the exact distance of a target or item. The laser targeting package adds a +1 bonus to strike with hand-held energy pistols, rifles, rail guns, etc. Maximum range: 2000 feet (610 m). Cost: 2300 credits.

7. Optics Enhancements: Passive nightvision (3000 feet/914 m range), telescopic (up to 20x magnification, one mile/1.6 km range), macro-lens (6x magnification), thermo-imager (2000 feet/610 m range), and light polarization. Cost: 2800 credits.

8. Mini-Radar/Sonar System: A miniature radar and/or sonar is built into the suit's chest and displays information on the HUD visor. The radar can track up to 12 targets and has a two mile (3.2 km) range. Cost: 3000 credits.

9. Integrated Sensor Pod: This sensor suite is a multi-dimensional, threat awareness system that provides the user with a heightened level of perception concerning his surroundings. It consists of a motion detector and mini-radar with 360 degree scanning capability. Threats are indicated on the HUD visor by flashing red icons. The pod provides bonuses of +3 on initiative, +2 to parry and dodge, +5 to roll with impact or fall, and allows the wearer to dodge all attacks, even those from behind and/or surprise. Cost: 4500 credits.

10. Advanced Communications Package: A sophisticated communications suite is built into the back of the suit, including a basic receiver/transmitter, secure cryptological encoding, burst transmission capability, and if the suit also has the HUD visor feature the system is capable of broadcasting and receiving text messages. Communications range is 30 miles (48 km). Cost: 3600 credits. **Note:** Other communications gear, sensors or surveillance equipment may be available under this category. Cost is 10% higher than the normal item because it comes in a protective case/container that can snap onto the armor. Containers with important or expensive gear have 10 M.D.C. (see Rifts® G.M. Guide for a comprehensive list and descriptions of gear).

11. IFF & Targeting Computer: A computerized recognition and identification system similar to the Wilk's PC-2020 Field Identifier system is built into the armor. The computer allows the operator to identify up to 6000 different targets with a 92% level of accuracy. Cost: 4000 credits.

12. Psionic Electromagnetic Dampers: An electromagnetic damper is integrated into the suit's helmet, providing the wearer with increased protection against psionics. Psychics find it difficult to read the thoughts and emotions of the wearer. Bonuses: +2 to

save vs all psionic attacks and possession attempts and +1 to save vs magic illusion and mind control. Cost: 1500 credits.

13. Deep Insertion Wilderness Package: Two extra canteens, compass, cigarette lighter, one pocket mirror, 4 signal flares, four colored smoke grenades (two colors), grappling hook and line (60 feet/18.3; lightweight), Pocket Laser Distancer, standard binoculars, hand axe (1D6 S.D.C.), field radio and an NE-09SP Survival Pack (detailed later in this section. May substitute the NG-S2 Basic Survival Pack described on page on page 187 of *Rifts® G.M. Guide* for a complete description). Cost: 32,000 credits.

14. Identification Package: Laser, Holographic, Portable Computer programmed according to needs. If military identification, it will contain thousands of images of known enemy insignias, uniforms, body armor, weapons, robots and combat vehicles. This is a Triax knock-off (see page 184 of *Rifts® G.M. Guide* or *World Book 5: Triax & NGR* for details). The package also includes a pair of passive nightvision binoculars, language translator and a laser distancer. Cost: 32,000 credits.

15. Mechanic's Package: One modular container holding a lock pick set and a lock release gun, roll of duct tape, and flashlight, and a second and third container for a Portable Tool Kit and a Portable Robotics Tool Kit or Portable Field Computer (see pages 186-187 of the *Rifts® G.M. Guide* for complete descriptions of gear). Cost: 10,000 to 22,000 credits (the latter is for the Robotics Tool Kit).

16. Medical Package: One modular container holding a standard First-Aid Kit, plus a Bio-Comp Monitor, an extra roll of bandages, 50 disposable surgical gloves, and a stethoscope, plus a second container holding an RAU "Cleaners" Kit and a Compu-Drug Dispenser, and a third modular snap-on container for an IRMSS "Surgical" Kit and an RMK "Knitters" Kit (see pages 184-186 of the *Rifts® G.M. Guide* for complete descriptions of gear). Cost: 140,00 credits.

17. Climbing Package: Special gloves with short, curved claws built into the fingertips, and grip tape on the fingers and palms of the hands, plus a sawed-off shotgun-looking weapon that fires a grappling hook and line (2D6 S.D.C. as a weapon, 500 foot/152 range, 600 lb/270 kg test, 6 grappling hooks, and 200 feet/61 m of lightweight line) or an Electro-Adhesive Pad. Cost: 18,000 with grappling hook, 40,000 with Electro-Adhesive Pads.

NE-BA-30 Light Combat Armor

Always a leader in combat technology, the Naruni Light Combat Armor is the equivalent of medium armor from most other manufacturers. It fulfills the role of standard infantry and is amazingly light and mobile for full environmental armor. A favorite of grunts, lawmen and espionage agents across the Megaverse.

Class: Thermo-Kinetic Environmental Battle Armor.

Size: Human equivalent.

Weight: 10 pounds (4.5 kg).

Mobility: Very good, only -5% to Prowl, Climb, Swim, Acrobatics and performing similar physical skills.

M.D.C. by Location:

Head/Helmet – 50

Arms – 30 each



Legs – 40 each

Main Body – 60

Cost: 55,000 credits (120,000 on the Black Market; rare).

Special Features: Standard properties for Naruni Thermo-Kinetic Armor.

Note: For an extra 35,000 credits, the armor can be surface coated with a fiber-optic material that can change colors to match the general environment, just like the best selling NE-C20 Camouflage Variable Armor. The color change takes 1D4 melees (15 to 60 seconds), in which the suit becomes the exact same color as the predominant one in the area. In the woods, the suit will

also create stripes and blotches of lighter and darker colors like a camouflage pattern. Bonus: +10% to camouflage/hide when motionless and concealed by underbrush (or a -10% penalty for others to Detect Ambush and Detect Concealment), and +5% to the wearer's Prowl skill. The fiber-optic material lasts for one year or 50 M.D. points of damage, whichever comes first.

NE-BA-40 "Infantry"

Medium Body Armor

Why wear the cheap second-rate armors offered by other manufacturer, when you can have the best armor in the Megaverse? The NE-BA-40 Infantry Armor is a full environmental battle armor with excellent protection and without sacrificing mobility. Our "medium" armor is tougher than most of our competitors' heavy armor, and don't forget the resistance to fire and impact attacks. **Class:** Thermo-Kinetic Environmental Battle Armor. **Class:** Thermo-Kinetic Environmental Battle Armor.

Size: Human equivalent.

Weight: 20 pounds (9 kg).

Mobility: Good, only -10% to Prowl, Climb, Swim, Acrobatics and similar physical skills.

M.D.C. by Location:

Head/Helmet – 70

Arms – 40 each

Legs – 60 each

Main Body – 100

Cost: 110,000 credits (200,000 on the Black Market; rare).

Special Features: Standard properties for Naruni Thermo-Kinetic Armor.

Note: For an extra 35,000 credits, the armor can be surface coated with the same fiber-optic material as the NE-BA-30 described previously.

NE-BA-50 "Raider"

Heavy Body Armor

The NE-BA-50 is a sleek, but heavily armored suit of full environmental body armor that can take more punishment than our competitors best heavy EBA. It is ideal for tackling cyborgs, Headhunters, Gunslingers, and Coalition Troops and when outnumbered.

Class: Thermo-Kinetic Environmental Battle Armor.

Size: Human equivalent.

Weight: 30 pounds (13.5 kg).

Mobility: Poor, -20% to Climb, Swim, Acrobatics, Prowl, and similar physical skills.

M.D.C. by Location:

Head/Helmet – 80

Arms – 55 each

Legs – 80 each

Main Body – 140

Cost: 160,000 credits (350,000 on the Black Market; rare).

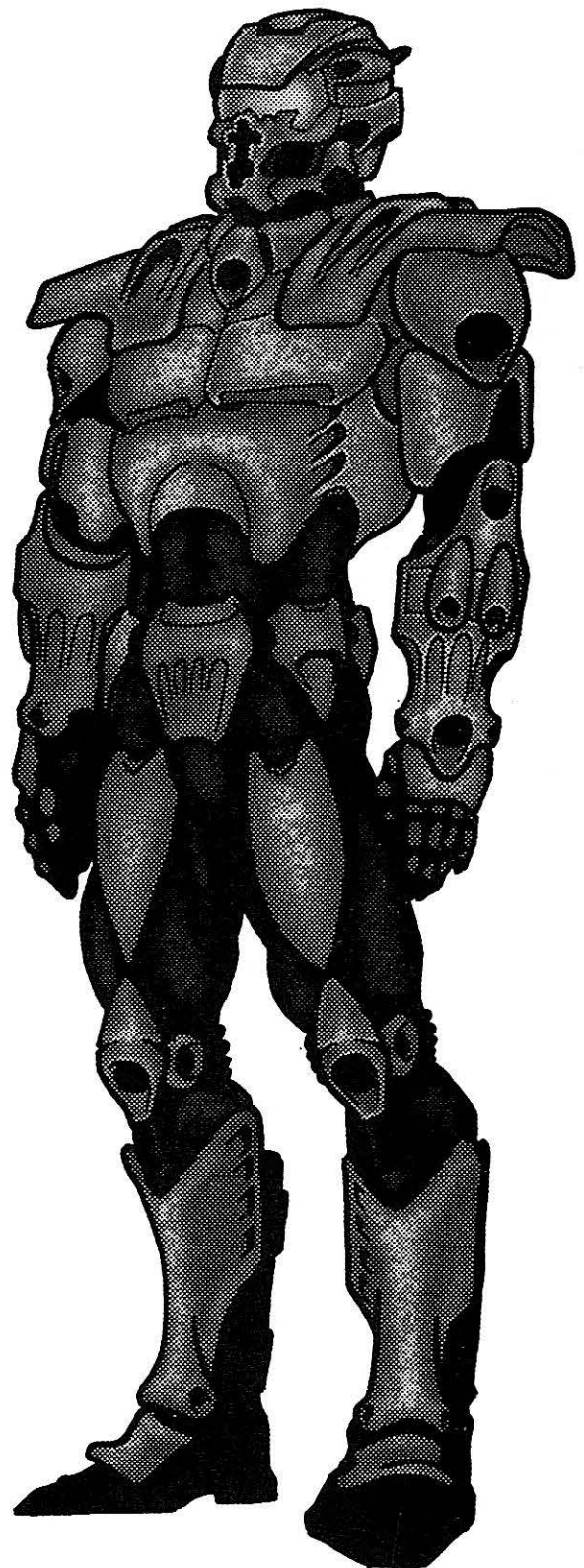

Special Features: Standard properties for Naruni Thermo-Kinetic Armor.

Note: For an extra 35,000 credits, the armor can be surface coated with the same fiber-optic material as the NE-BA-30 described previously.

NE-BA-55 "Super-Soldier" Exoskeleton Heavy Battle Armor

There are times when you want the heaviest protection possible, but you don't want or can't afford a full set of advanced power armor. That is when you need the fast, mobile, Super-Soldier Exoskeleton. The NE-BA-55 provides the wearer with a Robotic Strength and enhanced speed with minimal physical exertion on the part of the user. The Super-Soldier EBA incorporates the innovation of a rechargeable battery instead of a nuclear power pack. This keeps its cost down and makes the NE-BA-55 easy to maintain. The battery can be recharged by any vehicle or facility with a nuclear power plant or other type of modern generator. Each battery takes only three hours to recharge and provides 72 hours of continuous combat action. The Super-Soldier comes standard with one battery, though it is highly recommended to purchase two spares. The armor cannot use weapons that draw power from the suit, because it will reduce the available hours by half. Nor can the suit fly without a flight pack with an independent power supply.

Class: Full Environmental Exoskeleton Battle Armor.

Size: Human equivalent, plus about one foot (0.3 m), the exoskeleton is adjustable to fit a body between 5 feet (1.5 m) and 6 feet, 10 inches (2.08 m).

Weight: 120 pounds (54 kg), but the exoskeleton makes it seem as light and mobile as the NE-BA-50.

Mobility: Poor, -20% to Prowl, Climb, Swim, Acrobatics, and similar physical skills.

M.D.C. by Location:

- Head/Helmet – 100
- Arms – 90 each
- Legs – 100 each
- Main Body – 220

Special Features: Standard properties for Naruni Thermo-Kinetic Armor plus the following from light exoskeleton enhancement.

Speed: Triples the wearer's normal running Spd, and the act of running tires the user at 30% the usual rate of fatigue. **Leaping:** Increases the wearer's usual ability/range by 20%. Flight not possible without the NE-05GP Grav Pack or NE-07JP Jet Pack.

Physical Strength: Equal to a Robotic P.S. of 28.

Mega-Damage: 1D6x10 S.D.C. or 1D4 M.D. on a restrained punch, 1D6 M.D. with a full strength punch or kick and 2D6 M.D. from a power punch or leap kick.

Bonuses: +1 to parry, dodge and pull punch.

Cargo: None, other than the standard attachment points for a NE-01BP hardened backpack.

Power System: NE-EB electrical battery (72 hours of continual use from a single battery). The armor comes with one battery storage compartment on each hip for spare batteries (2), while the battery in use fits in a housing in the chest. NE-EB's cost 100,000 credits (one tenth the cost of a nuclear power pack), takes 2-3 hours to recharge from the same kind of facility that can recharge E-Clips or which draws from a nuclear generator, and are sold separately.

Weapon Systems: None. The wearer must use hand weapons, including most types of heavy rifles and light rail guns, as long as

it has an independent power supply. Many types of heavy handheld weapons are available from Naruni Enterprises.

Bonuses: +1 on initiative, parry and dodge, as well as one additional attack per melee.

Cost: 380,000 credits for the basic suit and one battery (800,000 on the Black Market; very rare). NE-EB batteries cost 100,000 credits each and two spare batteries are highly recommended, one spare is considered a must.

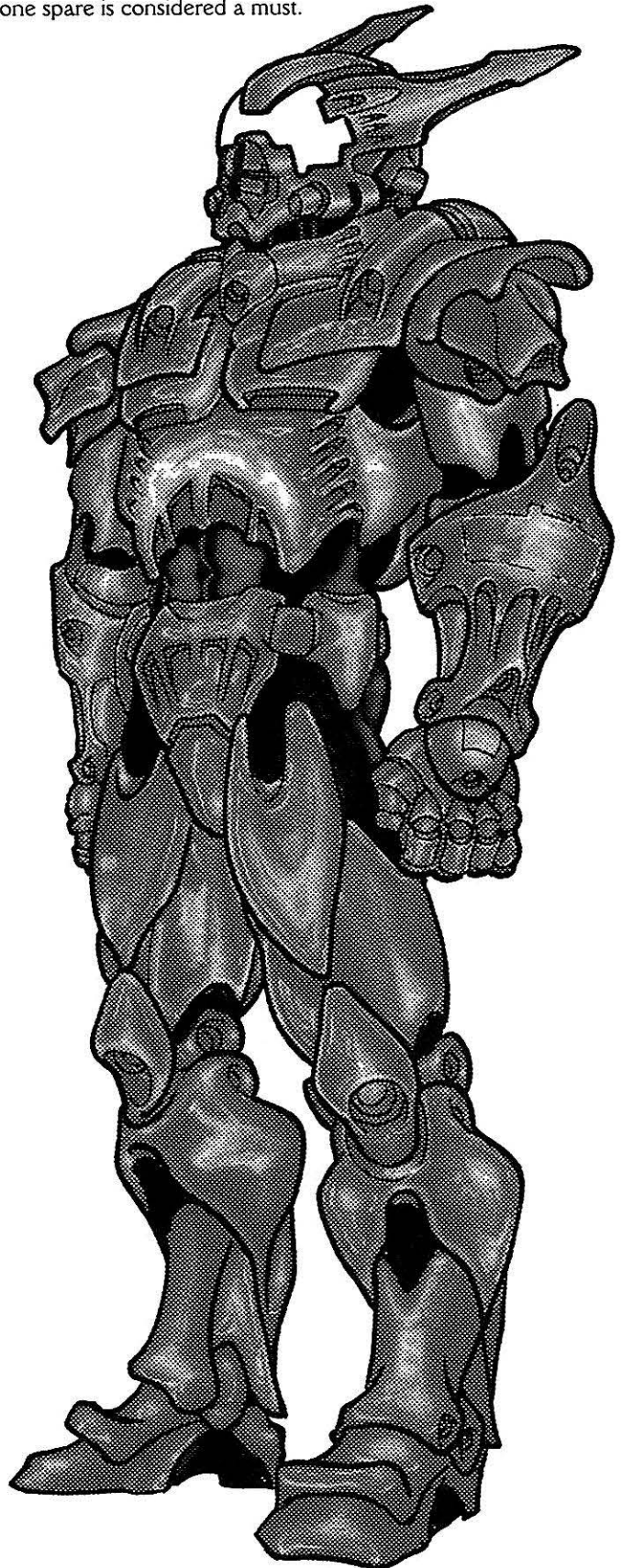

Body Armor

Accessory Packs

Naruni Enterprises offers an entire line of back mounted accessories for its new armor line, including the NE-01BP Backpack, NE-02S Servo Harness, NE-03DP Diving Pack, NE-05GP Grav Pack, NE-07JP Jet Pack, NE-09SP Survival Pack, and the much sought after NE-0XWP Servo-Weapon Pack (a combination of servo-rig and backpack energy supply).

NE-01BP Backpack

This is a hardened backpack suitable for normal utility storage and field use. The NE-01BP Backpack is about the size of a large unit, footlocker or small chest. It is airtight, floats in water and has an auxiliary carrying handle so it can be lifted like a suitcase.

Weight: 5 lbs (2.25 kg).

Pack M.D.C.: 35

Cost: 2,000 credits.

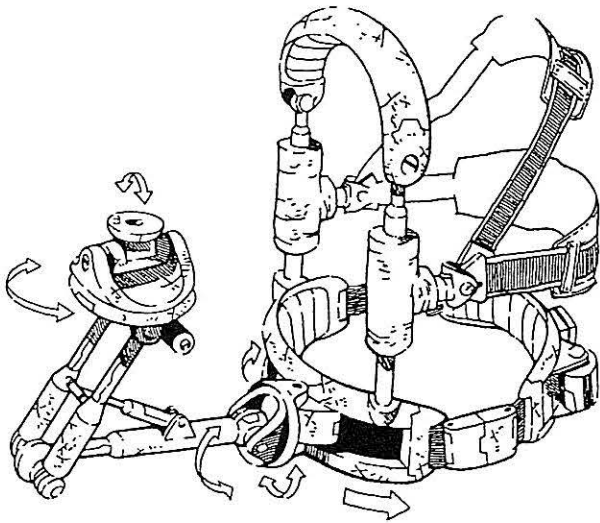

NE-02S Servo-Harness (Basic)

Many heavy weapons are supported with a shoulder and/or back and chest harness, with the gun itself "slung" under the arm or over the shoulder when not in use. This harness is called a "Servo-Harness Rig," or simply a "Servo-Harness." The Rig enables Headhunters, cyborgs and other types of augmented ground troops to carry and use weapons larger and heavier than they could normally handle. This includes rail guns, heavy energy weapons, cannons, and missile launchers. It is worn like a parachute harness over body armor. There are two popular styles of the Weapon Rig, but both are made of padded, M.D.C. metal bars and M.D.C. ceramic plated straps linked to a gyro-stabilizer

and a light hydraulic system. The weapon connector unit is modular to accommodate most of Naruni Enterprises' heavy weapons (the Warlords of Russia have a similar "Rig"). It lets an individual use the weight of his entire body to maneuver and hold a weapon steady, giving the warrior the capability of fielding big guns. A weapon mated to the Servo-Harness Rig must be carried under one arm or over the shoulder. What it all boils down to in game terms is that an individual with a P.S. as low as 10 can carry and use weapons equaling his body weight x2. For Example: Sean weighs 160 pounds (72 kg) and has a P.S. Attribute of 11. Using a Servo-Harness Rig, he can now field a rifle weighing 320 pounds (144 kg).

Weight: 20 lbs (9 kg).

Harness M.D.C.: 25

Cost: 10,000 credits.

NE-03DP Diving Pack

The Diving Pack is a combination of underwater jet pack and additional oxygen supply used for underwater reconnaissance, repair work, demolitions and other operations. It can be affixed to the standard back mounting on any Naruni armor, and although the NE-03DP is fairly lightweight it does provide divers with enhanced speed, distance and more oxygen, increasing the diver's operation range underwater.

Maximum Speed: 60 mph (96 km or 52 knots).

Maximum Range: 700 miles (1120 km), before the unit's NE-EB electrical battery must be recharged. A compartment on top of the NE-03DP holds a spare. NE-EB electrical batteries cost 100,000 credits and will run the Diving Pack for up to 96 hours; sold separately.

Additional Air Supply: Ten hours.

Weight: 40 lbs (18 kg).

Pack M.D.C.: 45

Cost: 70,000 credits for the Diving Pack, plus 100,000 credits for each NE-EB battery.

NE-05GP Grav Pack

The NE-05GP Grav Pack is the next step in one-man flight, brought to you by Naruni Enterprises. With unlimited range, speed and performance, the NE-05GP leaves all conventional jet packs in the dust. Fully contained with a ten year nuclear power system, the Grav Pack is the worry free flight option. For those on a budget, may we suggest the NE-07JP Jet Pack?

Maximum Speed: 400 mph (640 km), but in the vacuum of space a speed of Mach one (660 mph/1056 km) can be reached.

Maximum Range: Unlimited range, due to the nuclear engine, which is good for an amazing 10 years.

Weight: 45 lbs (20.25 kg).

Pack M.D.C.: 50

Cost: 2.1 million credits; poor availability even through Naruni Enterprises. No one else on Rifts Earth has an anti-gravity flight system.

Note: The Grav Pack is controlled through a wrist controller or neural connections if the character has a headjack (if neural connectors are used, the wearer is at +1 to dodge while flying).

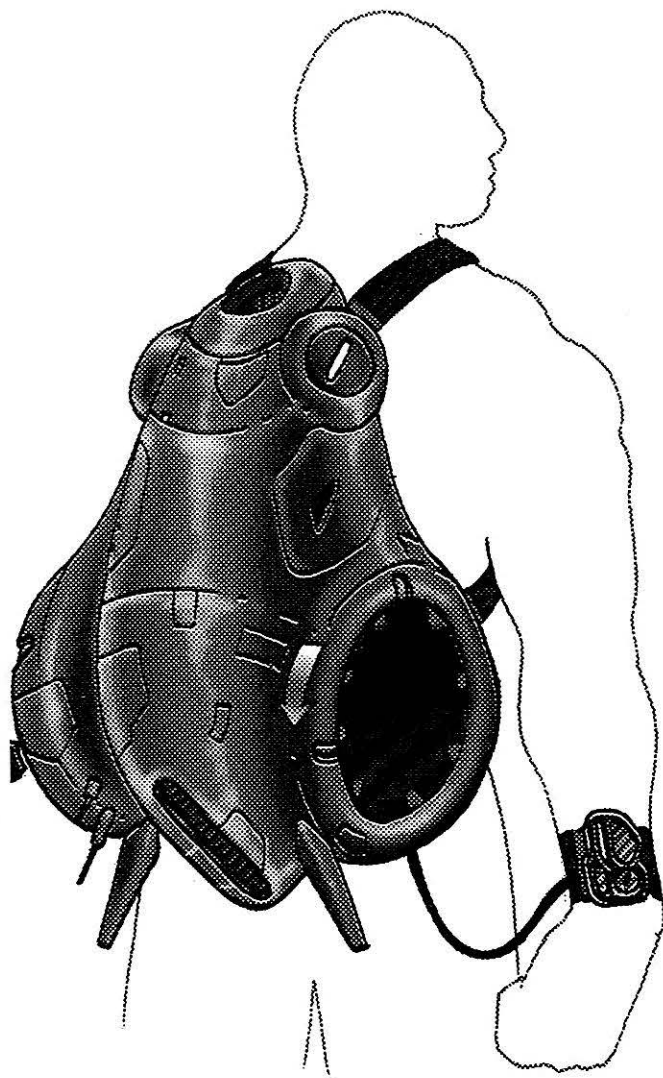

NE-05GP Grav Packs can be very useful for imaginative operators. By trading speed for load capacity, a Grav Pack can be used to lift heavy weights. The maximum weight a Grav Pack can carry at full speed, however, is 500 lbs (225 kg). Doubling the weight to 1000 lbs (450 kg) reduces maximum speed to 100 mph (160 km). Up to one ton (900 kg) can be carried at 50 mph (80 km), and two tons (1,800 kg) can be moved or pushed at a speed of 2 mph (3.2 km), but once you get the two tons moving, it will take a great deal of force and time to stop. Remember that a normal human wearing the Grav Pack cannot carry super-heavy weights himself. Instead, the Grav Pack must be strapped to the object to be lifted, and the user must climb on top of the object to operate the controls and to steer. Using a Grav Pack in this way can be very dangerous!

NE-07JP Jet Pack

This is Naruni Enterprises' all-purpose utility jet pack, designed to be affordable and yet offer superior capabilities. The NE-07JP Jet Pack cannot be used underwater.

Maximum Speed: 360 mph (576 km).

Maximum Range: 8000 miles (12,800 km) or 48 hours of flight time before the unit's NE-EB electrical battery must be recharged. A compartment on top of the NE-07JP holds a spare.

Weight: 35 lbs (16 kg).

Pack M.D.C.: 40

Cost: 90,000 credits for the Jet Pack, and 100,000 credits for each NE-EB battery, sold separately. Two batteries are highly recommended.

NE-09SP Survival Pack

The survival pack fills a basic need for those on Rifts Earth, as witnessed by the success of the NG-S2 Basic Survival Pack produced by Northern Gun. Naruni Enterprises, never one to scoff at a good idea, has released a survival pack of its own for our new line of body armor. After all, imitation is the sincerest form of flattery, right? But our pack is better and cheaper!

Weight: 10 lbs (4.5 kg).

Pack M.D.C.: 30

Cost: 2,500 credits.

The NE-09SP Contains the following:

- Two-Person Tent: Folded, it's the size of a paperback book. Unfolded, it can sleep two people comfortably. Offers protection against the cold and rain; insulates and keeps people inside relatively warm at temperatures up to -40 degrees Fahrenheit. The tent has a water collection system to help the user(s) survive in desert climates as well. The tent collects all moisture that evaporates from the occupants, basically increasing any water supplies the user carries by 20%; with the tent, ten days of water will last twelve days.
- A large, two-person sleeping bag, also tightly folded.
- Flashlight with a concealed pocketknife and 6 batteries (each battery has a life of 48 hours of continuous use).
- Compass / inertial mapper; lets you know how far you've traveled and in which direction(s): +15% to Land Navigation rolls. The compass has a mirror finish on one side and can use the sun to signal others or send Morse-code messages.
- Mini-First-Aid Kit: A roll of gauze, 48 adhesive bandages (different sizes), roll of medical tape, pair of small scissors, pocketknife, and a tube of protein healing salve.
- Snake Bite Kit, with antitoxins (6 doses) for most known venomous snakes and creatures in North America.
- Hunting and Fishing Kit: Wires, fishing line and several hooks and pulleys, useful for both fishing and setting small snares.
- Saw-Wires (3): A serrated, ultra-hard wire with two ring handles, able to cut through wood, stone and even S.D.C. metals. Does most of the chores of an axe, but with less time and effort.
- Fire Starter: A pocket cigarette lighter and a flint striker with 6 extra flints (good for starting hundreds of fires).
- Six Heat Packs (the size of a paperback book, each lasts for 4 hours).
- Survival Knife, a small hatchet, six signal flares and two smoke grenades, for signaling help.
- 30 feet (9.1 m) of lightweight climbing cord, a pair of climbing gloves, four ceramic spikes and a small mallet.
- Bar of soap, a washcloth and towel.
- Large canteen and eight days (up to 16 days with rationing) of concentrated food rations.
- Vitamins and fat pills, for cold weather (enough to last for 16 days, up to 32 days with rationing).

NE-0XWP Servo-Weapon Pack

The Servo-Weapon Pack is a combination of heavy, reinforced Servo-Rig and portable power supply, designed to allow our human customers to more easily use our new line of even heavier grade weapons. Many heavy weapons are supported with the gun on the shoulder and are slung over the shoulder when not in use. The NE-0XWP enables ground troops to carry and use weapons larger and heavier than they could normally handle by getting the weapon off their shoulder and mounting it on an articulated arm the same as the basic Servo-Harness Rig. A weapon mated to the Servo-Weapon Pack arm must be carried under one arm or over the shoulder. What it all boils down to in game terms is that an individual with a P.S. as low as 9 can carry and use weapons equaling his body weight x2. The built-in energy supply provides additional power (and firepower) to energy weapons and to run light equipment.

Energy Supply: A unit that looks like an E-Clip attached to a cable is connected to the energy supply of the NE-0XWP,

which is used to fit into a weapon, generator or other machine. The energy supply of the Servo-Weapon Pack can run everything from computers to light machines, but the energy supply is designed to power heavy weapons held by the NE-0XWP. The energy supply consists of a single NE-EB electrical battery which offers the equivalent payload of 10 standard E-Clips (about 200 blasts that inflict 4D6 M.D. or less). It is much more efficient at powering machines and can power a vehicle or run a dozen or more machines, furnaces, light to heavy generators, electronics, computer systems and as much as the lights and appliances of a large house for 96 hours before requiring recharging. A slot on top of the NE-0XWP holds a spare NE-EB electrical battery.

Weight: 40 lbs (18 kg).

Pack M.D.C.: 60

Cost: 170,000 credits including one NE-EB battery; additional batteries are sold separately for 100,000 credits each.

Power Armor & Robots

NE-EA35 “Earth Angel” Also known as the “Flying Knight”

Market research on Earth revealed the public’s fascination with, and love for, power armor in general and flying power armor in particular. Perhaps the most famous and feared flying power armor of them all is the old and new style Coalition SAMAS. We also realize that many potential customers of Naruni power armor cannot afford the 25 million credits for our Mecha-Knight. Numerous cash-strapped mercs, kingdoms and adventurers turned to other manufacturers like Northern Gun and Chipwell that offer buyers inexpensive power armor. To increase its share of the power armor market and expand Earth-based sales, Naruni Enterprises has slashed the price of the Mecha-Knight to 15.2 million credits, and now offers a range of ground and flight capable power armor, as presented in this very catalog. But we want to bring special attention to the NE-EA35 Earth Angel.

To keep costs down, the Earth Angel is built using less expensive materials, technology and manufacturing processes. This makes the power armor inferior to many Naruni Enterprises products, but still provides a worthwhile, multi-purpose suit of power armor on par with our Earth competitors. Whether by accident or design, the exoskeleton resembles the True Naruni, with three tubes – combination air hose and power cables – attached to the lower face plate and connected to the armored chest. In Phase World this has given the armor (known in other venues as the “Flying-Knight”) the unofficial nickname of “Naruni True” power armor.

Model Type: NE-EA35

Class: Strategic Armor Military Assault Suit.

Crew: One.

M.D.C. by Location:

Shoulder Wings (2) – 90 each

Main Rear Jets (3) – 70 each

*Lower Maneuvering Jets (3) – 30 each

Arms (2) – 70 each

*Hands (2) – 15 each

Plasma Cartridge Light Machine Gun – 75

Ammo Drum (rear) – 65

*Particle Beam Gun – 50

*Mini-Missile Launchers (2) – 40 each

*Helmet Air/Power Cables (3) – 25 each

Legs (2) – 90 each

** Head – 100

*** Main Body – 280

* All areas that are marked with a single asterisk are small and difficult targets to hit. They can only be hit when a character makes a called shot, and even then the attacker is -4 to strike (-6 to strike the helmet air/power cables). If the three cables connecting the head and chest are severed the suit is no longer environmental and power to the helmet is cut off, meaning that the pilot no longer receives power armor bonuses to strike, parry, and dodge.

** Destroying the head/helmet has a 01-70% chance of knocking the pilot unconscious. If conscious, the pilot has two problems; one, no power armor combat bonuses to strike, parry, and dodge, and two, the human head is now vulnerable to attack. **Note:** The head is a small and difficult target to hit. Thus, it

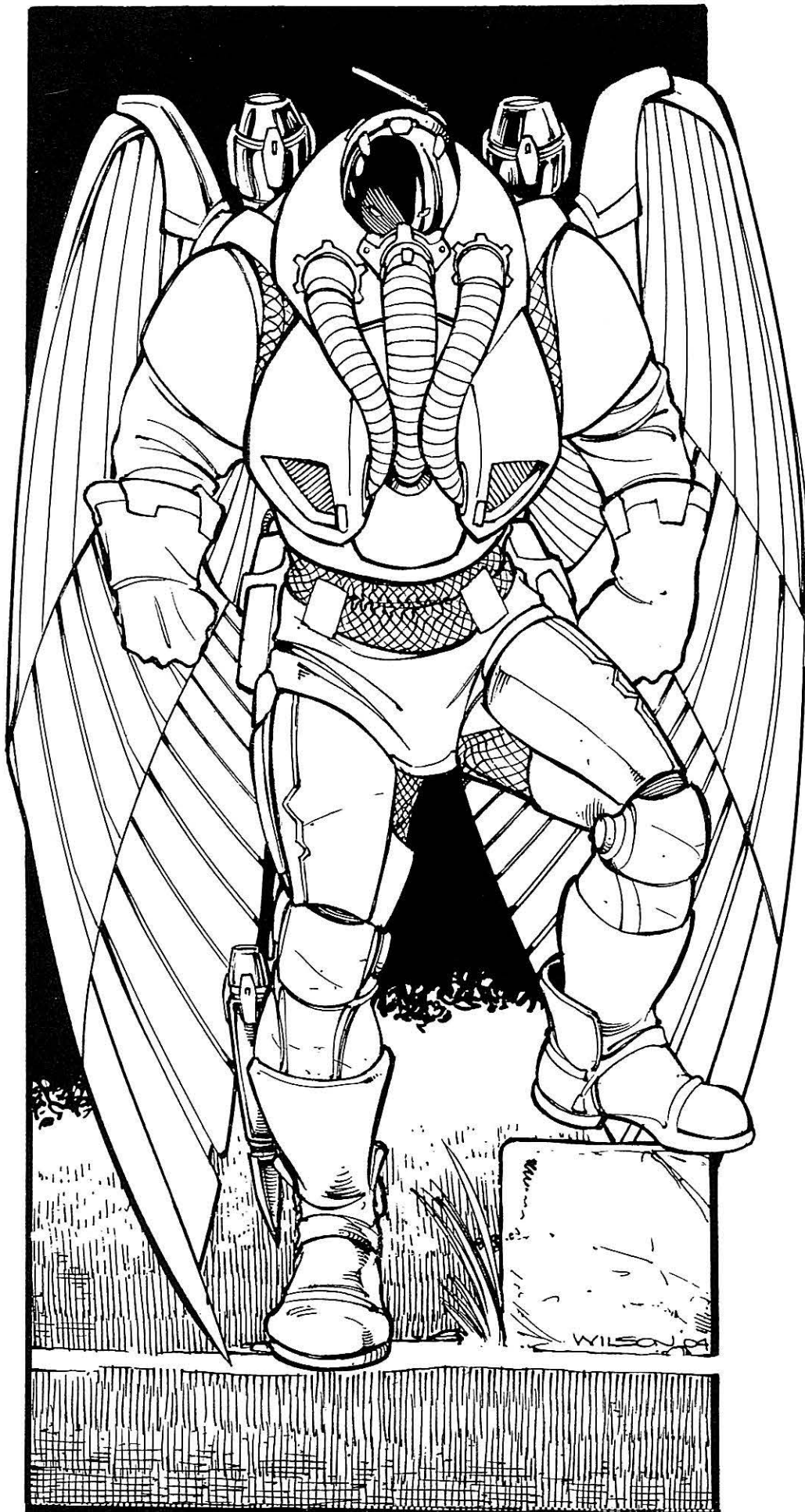

can only be hit when a character makes a called shot and even then the attacker is -3 to strike.

*** Depleting the M.D.C. of the main body will shut the armor down completely, and the pilot will be vulnerable to attack. **Note:** Destroying one of the wings makes flight impossible, but the suit can still make jet assisted leaps. If the ammo drum is destroyed there is a 01-90% chance of the plasma cartridge ammunition detonating, which inflicts 3D6x10 M.D. to a 40 foot (12 m) area.

Speed:

Running: 60 mph (96 km) maximum. The act of running tires the pilot, but at 10% the usual fatigue rate thanks to the robot exoskeleton.

Leaping: The exoskeleton augmented legs can leap up to 10 feet (3 m) high or across unassisted by the thrusters. A jet thruster assisted leap can propel the armor up to 200 feet (61 m) high and 400 feet (122 m) across without actually attaining flight.

Flying: The rocket propulsion system enables the Earth Angel to hover stationary up to 1000 feet (305 m) or fly. Maximum flying speed is 500 mph (800 km), but cruising speed is considered to be 250 mph (400 km). Maximum altitude is limited to 5000 feet (1524 m).

Flying Range: The nuclear power system gives the Earth Angel decades of life, but the jet rockets get hot and need to cool after ten hours of flight when traveling at speeds above cruising, and twenty hours at cruising speed; can fly indefinitely when paced with short rest stops.

Underwater Capabilities: The Earth Angel is not designed for underwater combat but is capable of functioning in water. It cannot swim or fly under the waves, but can walk or run on the floor of rivers, lakes and seas at a maximum speed of 30 mph (48 km/26 knots). Maximum Ocean Depth: 4000 feet (1219 m).

Statistical Data:

Height: 8 feet, 6 inches (2.6 m).

Width: 3 feet, 9 inches (1.1 m), or 12 feet (3.6 m) with wings fully extended.

Length: 4 feet, 6 inches (1.3 m).

Weight: 680 lbs (306 kg).

Physical Strength: Equal to a Robotic P.S. 26.

Cargo: None.

Power System: Nuclear; average energy life is 10 years.

Cost: 4.2 million credits for a brand new, fully loaded suit. Extra ammunition costs separately.

Weapon Systems:

1. Plasma Cartridge Light Machine Gun: This is the primary armament of the Earth Angel, a smaller, light machine-gun variant that fires NE-001PC "Light" Plasma Cartridges. Ammunition is belt fed from an ammo drum mounted on the back; works similar to the C-40R rail gun of the standard CS SAMAS power armor.

Primary Purpose: Assault.

Mega Damage: A single shot inflicts 3D6 M.D., or a 10 shot burst inflicts 2D4x10 M.D.

Rate of Fire: A single shot or burst counts as one melee attack.

Effective Range: 2000 feet (610 m).

Payload: 1000 round drum, that's 100 bursts. Reloading a drum takes about 5 minutes for those not trained, but just one minute by a trained soldier.

2. Particle Beam Blaster: Built into the left forearm gauntlet is a particle beam gun, intended for use as a back-up weapon and also for close combat.

Primary Purpose: Close Combat/Assault.

Secondary Purpose: Defense.

Mega Damage: 1D4x10 M.D.

Rate of Fire: Equal to hand to hand attacks per melee.

Effective Range: 2000 feet (610 m).

Payload: Unlimited. The particle beam gun draws power from the nuclear power supply, giving it an effectively unlimited payload.

3. Mini-Missile Launchers (2): A pair of mini-missile launchers are mounted on the back behind the shoulders. These launchers are capable of firing any standard type of mini-missile, including those manufactured on Earth as well as those of Naruni Enterprises design.

Primary Purpose: Anti-Armor and Anti-Aircraft.

Secondary Purpose: Defense and Anti-Personnel.

Mega-Damage: Varies with missile type. Any standard mini-missile type can be used (5D6, 1D4x10 and 1D6x10 M.D. depending on type).

Range: One mile (1.6 km).

Rate of Fire: One at a time or volleys of two or four.

Payload: 16 mini-missiles total.

4. Boot Holster: Can accommodate most types of energy pistols. Optional use; weapon sold separately.

5. Hand to Hand Combat: Rather than use a weapon, the pilot can engage in Mega-Damage hand to hand combat.

Bonuses and Damage from Earth Angel Combat Training:

Restrained Punch: 1D4 M.D.

Normal Punch: 1D6 M.D.

Power Punch: 2D6 M.D., but counts as two melee attacks.

Kick: 1D6 M.D.

Leap Kick: 2D6 M.D., but counts as two melee attacks.

Bonuses: +1 on initiative, +1 to strike, parry and dodge, +3 to dodge when in flight, +2 to disarm, and +2 to roll with impact. +1 melee attack at levels 2, 5, 10, and 15.

6. Sensor System Note: The Earth Angel has all of the standard features and systems of power armor suits, plus a complete optics package including laser targeting, telescopic (up to 10x magnification, range is 2 miles/3.2 km), passive nightvision (4000 foot/1220 m range), thermal-imaging (2000 foot/610 m range), and ultraviolet (3000 foot/914 m range).

NE-AA30 "Space Angel"

By Patrick Nowak & Kevin Siembieda

In the Three Galaxies, jet packs are extremely popular for rapid deployment of infantry forces, covert infiltration, ship boarding and similar operations. Naruni Enterprises manufactures a SpaceJet pack that utilizes state-of-the-art, FTL age technology, and is capable of flying both within an atmosphere as well as the deep reaches of space. Ah, but for the people of North America, the Space Angel has a third capability that is very handy in the Midwest and Eastern part of the country with all of its lakes, the Space Angel has full underwater capabilities. Need to hide or escape from the Coalition or a Splugorth Slaver? Dive underwater. Looking to surprise your opponent? Rise up from under the waves.

The patented SpaceJet jet pack can reach an incredible speed of Mach 1.5 (1050 mph/1680 km) in an atmosphere, triple that in space, and 340 mph (544 km) underwater. The reinforced suit has a special internal system of features to help the pilot endure the G forces as well as an automatic locking system that locks the arms and legs in a rigid position when flying at 70% of maximum speed to cut through air like a missile and through water like a torpedo. In fact, in rigid rocket mode, the power armor has the same radar/sonar signature as a missile/torpedo which effectively disguises the power armor's true nature. To engage in combat, however, the power armor must slow down to 500 mph (800 km) or 180 mph (288 km) underwater. Plus the armor features an environmental overpressure system that puts pressure on the operator's legs and abdominal region to keep blood in the chest cavity and head to prevent blackouts while executing special maneuvers (the suit and SpaceJet pack are calibrated to the specific anatomy of the operator at the time of purchase). This pressurization system also give the all-environment power armor the capability of surviving underwater depths of up to two miles (3.2 km).

In an atmosphere, the Space Angel is about as fast and maneuverable as many light fighter aircraft on Rifts Earth, and is easily as capable as any model of the Coalition States' famous SAMAS. Pilots will find it suitable for any purpose from aerial reconnaissance and scouting/patrolling to light combat. The system is a favorite among speed junkies, daring mercenaries and seafaring pirates. In addition to the all-purpose, all-terrain, all-environment SpaceJet armor being extremely fast, incredibly agile, versatile and quiet, it looks as cool as hell, cutting an imposing figure in any situation. Take it for a test drive and see for yourself.

Model Type: NE-AA30 Armor & SpaceJet Pack.

Class: Combat Power Armor and Multi-Flight System.

Crew: One.

M.D.C. by Location:

* Wings (2) – 75 each

* SpaceJet Pack (1; back jets) – 120

** Head/Helmet – 90

* Hands (2) – 25 each

Arms (2) – 75 each

Legs (2) – 100 each

*** Main Body – 250

* A single asterisk indicates a small and/or difficult target to strike, requiring the attacker to make a "called shot" to hit them, but even then the attacker is -4 to strike.

** Depleting the M.D.C. of the head/helmet eliminates all forms of optical enhancements, sensory systems and targeting, forcing the pilot rely on his own human senses. It also eliminates any power armor combat bonuses. **Note:** If in space, underwater or an otherwise deadly environment, the pilot will suffocate, choke and die within 1D4 minutes.

*** Depleting the M.D.C. of the main body shuts the armor down completely, making it useless and the pilot inside vulnerable to future attacks. It is suggested that all pilots wear a suit of Cermalyte body armor for additional protection (28 M.D.C.).

Destroying one wing reduces speed by 20% and inflicts a penalty of -1 to dodge. Destroying both wings reduces speed by 40% and inflicts a penalty of -3 to dodge and -20% on all special aerial maneuvers.

Depleting the M.D.C. of the SpaceJet pack destroys the propulsion system. If in the air and the wings are intact, the pilot can glide to a safe ground landing, if one is destroyed he crashes (takes 2D4x10 damage). If underwater the character is "dead in the water" and must rely on swimming as his only means of locomotion. In space he is set adrift.

Speed:

Running: 50 mph (80 km) maximum. The act of running does tire out its operator, but at 10% of the usual fatigue rate.

Leaping: It is possible to make "jet assisted" leaps without actually attaining flight, to a maximum height of 500 feet (152 m) and 2000 feet (610 m) across. Cannot leap more than six feet (1.8 m) high or across with the SpaceJet attached (too heavy and unbalancing), but can leap 15 feet (4.6 m) high and 20 feet (6.1 m) across with the jet pack removed (increase by 30% with a running start).

Flying: Up to Mach 1.5 (1050 mph/1680 km) in atmosphere! In space where there is no friction or gravity, the SpaceJet backpack can propel the Space Angel triple that speed. Cruising speed is usually 300-400 mph (480-640 km); VTOL capable. Wings can fold flat when necessary.

Flying Range: A miniaturized nuclear power plant gives the SpaceJet years of life. The jets need cooling, however, after 12 hours of continuous use at cruising speed, or six hours at maximum speed in atmosphere or underwater; can go three times as long in outer space. Maximum altitude is 18,000 feet (5486 m), the pack is unable to escape a planet's gravity on its own, but if transported by a spacecraft into orbit it is capable of flying in space.

Underwater Capabilities: Swimming with the wings folded back, the Space Angel can swim using the same types of paddling of the legs and arms as a human at a maximum speed of 4 mph (6.4 km/3.4 knots). It can also walk along the bottom of the sea at about 25% of its normal running speed. Using the SpaceJet it can slice through water like a torpedo up to a speed of 340 mph (544 km/294 knots) or skim along the surface at the same speed. Maximum Ocean Depth: 2 miles (3.2 km).

Statistical Data:

Height: +4 inches (0.1 m) taller than the wearer; adjustable to fit anybody between 5 feet to 6 feet, 10 inches (1.5 to 2.08 m).

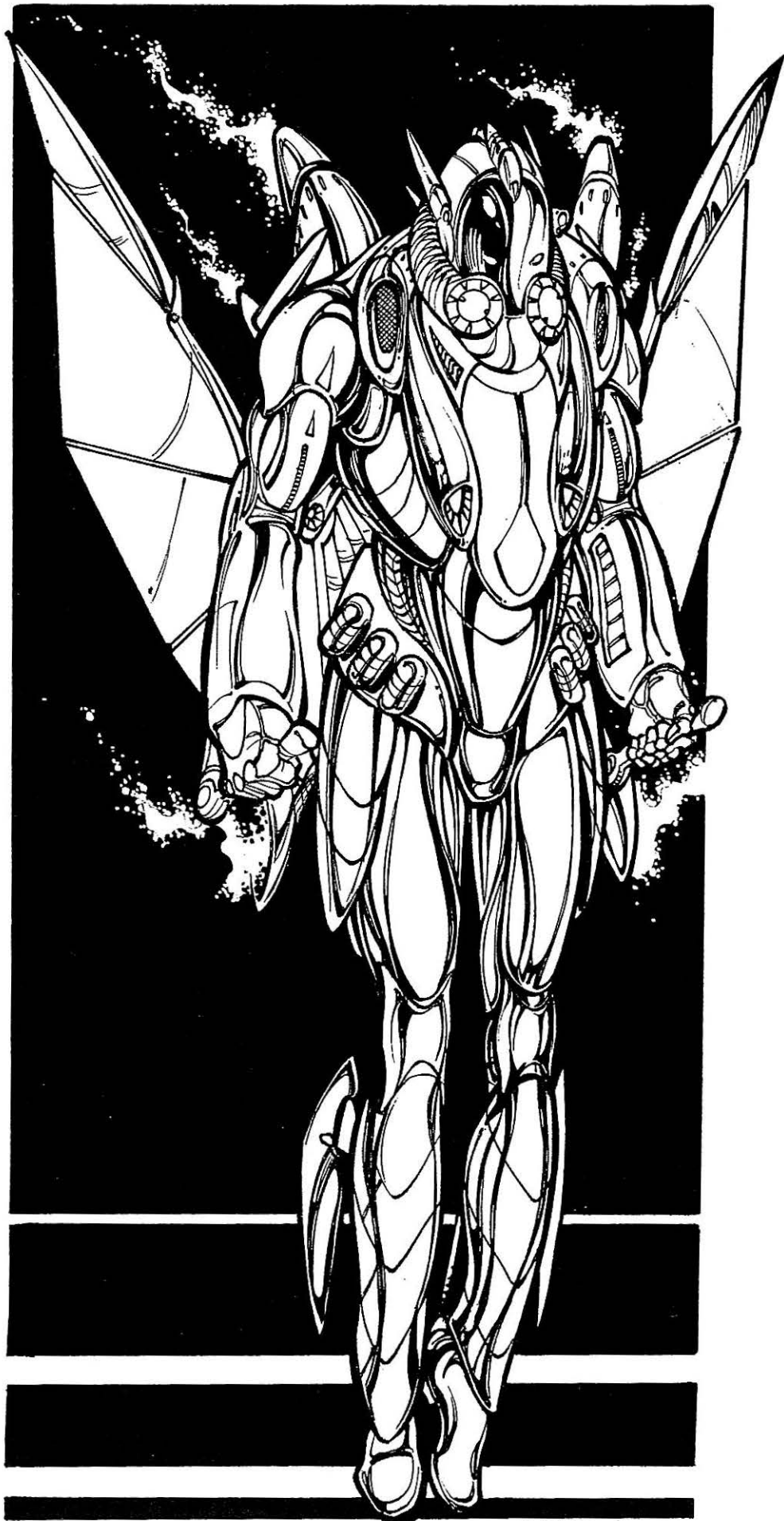

WILSON 2009

Width: Approximately 2 feet (0.6 m) from shoulder to shoulder; varies with the size and bulk of the pilot. 11 feet (3.3 m) with the wings fully extended.

Length: 3 feet (0.9 m) with the SpaceJet in place.

Weight: 328 lbs (147.6 kg) plus the detachable SpaceJet weighs 150 lbs (67.5 kg).

Physical Strength: +10 to the operator's P.S. attribute, and considered Robotic P.S.

Cargo: None.

Power System: Nuclear; average energy life is 10 years.

Cost: 8.7 million credits.

Weapon Systems:

1. **Missile Launchers (Optional):** Up to two short-range missiles or four mini-missiles can be mounted on each of the wings, but the addition of missiles prevents them from being able to fold up flat, must remain extended.

Primary Purpose: Anti-Aircraft and Anti-Armor.

Secondary Purpose: Assault and Defense.

Missile Type: Any standard short-range or mini-missile type can be used, but standard issue is K-HEX high explosive (mini-missile: 1D4x10 M.D., short-range missile: 2D6x10 M.D.), or plasma (1D6x10 M.D.).

Mega-Damage: Varies with the missile type.

Range: Mini-Missiles: One mile (1.6 km), Short-Range Missiles: 5 miles (8 km).

Rate of Fire: One at a time or volleys of two, four or six.

Payload: 10 mini-missiles or 6 short-range missiles total.

2. **Hand to Hand Combat:** Rather than use a weapon, the pilot can engage in Mega-Damage hand to hand combat. Damage is as per Robotic P.S., but does a minimum of the following:

Restrained Punch: 6D6 S.D.C.

Normal Punch: 1D4 M.D.

Power Punch: 2D4 M.D., but counts as two melee attacks.

Kick: 1D6 M.D.

Leap Kick: 2D6 M.D., but counts as two melee attacks.

Bonuses: In addition to those provided under #3, below, +1 on initiative, +1 to strike and disarm, +2 to pull punch and +3 to dodge when flying faster than 200 mph (320 km) and +10% for high speed and trick maneuvers.

3. **Sensors & Features of Note:** In addition to all the features that usually come standard with all Earth power armor are the following.

1. **Advanced HUD Visor:** A Heads Up Display that projects data, charts, topographical maps, orders and mission information, and video transmissions on the visor of the helmet for the wearer to see. As many as six different HUD viewing sections/images can be projected without impairing the vision of the wearer.

2. **Optical Enhancements:** Optics package includes telescopic (up to 10x magnification, range is 2 miles/3.2 km), passive nightvision (3000 foot/914 m range), and thermal-imaging (1500 foot/457.2 m range).

3. **Integrated Sensor Pod:** This sensor suite is a multi-dimensional, threat awareness system that provides the user with a heightened level of perception concerning his surroundings. It consists of a motion detector and mini-radar with 360 degree scanning capability and range of 10 miles (16 km); quadruple in

space, half that range underwater. Threats are indicated on the HUD visor by flashing red icons. The pod provides bonuses of +3 on initiative, +2 to parry and dodge, +4 to roll with impact or fall, and allows the wearer to attempt to dodge all attacks, even those coming from behind provided the attacker is within sensor range. Works both on the ground and while flying.

4. **Rocket Piloting System:** A special system that locks the pilot's extremities into a rigid position, and overpressure system that keeps pressure on the legs and torso to help the pilot survive the extreme G forces resulting from high speed maneuvering. This system allows even normal humans to fly the SpaceJet without penalties.

5. **Sound Suppression System:** The SpaceJet pack is equipped with a special silencing system that muffles the sound of the rocket jets, making the vehicle comparatively silent in slow speed flight and difficult to detect. Maximum speed while the suppression system is in use is 100 mph (160 km).

NE-SA40 Stealth Power Armor

Also known as the "Black Fist"

By Patrick Nowak & Kevin Siembieda

NE-SA40 is a lightweight exoskeleton suit that falls somewhere between regular body armor and true power armor in combat power. The suit provides its wearer with an augmented, Robotic Strength and heavier armor protection than a standard body armor suit, but at the same time it lacks the characteristic heavy weapon systems, missile launchers, nuclear power plant and flight propulsion of most power armor suits. However, the NE-SA40 is not a poor man's power armor, it is designed for speed, climbing, stealth and espionage for spies, secret agents, master thieves, assassins and military special forces.

The primary focus of the Stealth is black ops and silent movement. Naruni Enterprises' goal: to create an armor suit that is as close to silent and invisible as possible without the use of magic. To this end, the R&D team sacrificed heavy armor protection, firepower and flight to make the exoskeleton smaller (man-size), stealthier and more agile than anything ever seen before. The NE-SA40 armor is constructed almost entirely with radar absorbent materials, and masks infrared and thermal emissions to make the wearer's body heat invisible to infrared and thermal optics systems and sensors. Numerous exterior areas of the suit, those likely to come in contact with surfaces, including the toes, soles and heels of the boots, hands, elbows, knees, etc., are coated with a sound absorbing material to disperse and muffle sound.

Naruni Enterprises markets this exoskeleton suit as the utmost in modern infiltration and espionage technology. Millions have been sold throughout the Three Galaxies, but it is available on Earth for the very first time. Ideal for dedicated military special forces operatives, espionage agents, assassins, bounty hunters, ninja, industrial spies, private investigators, thieves and freedom fighters and adventurers who'd like no one to notice their comings and goings. (Game Note: Northern Gun has reputedly ac-

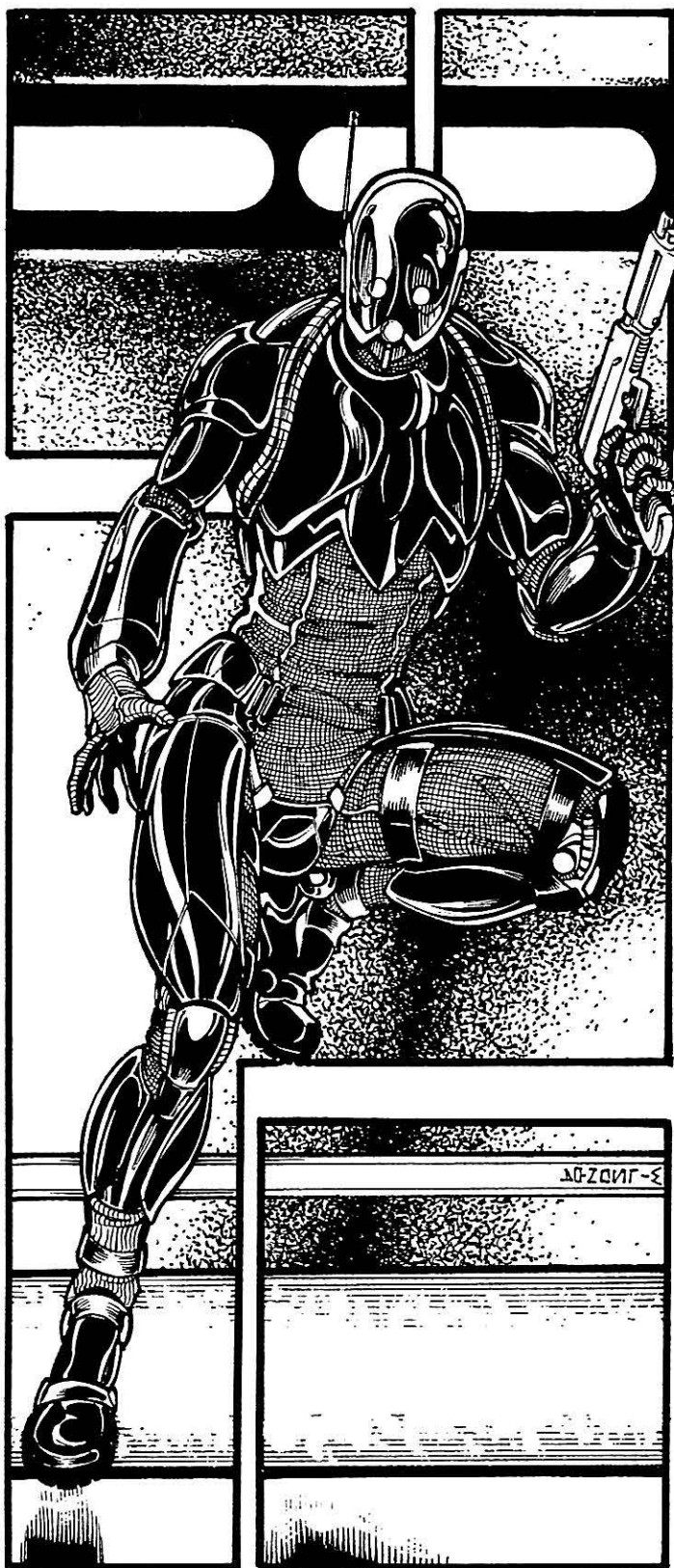

quired two of the suits in hopes of reverse engineering them and duplicating the technology. So far, it is much too alien and advanced for them to figure out.)

Model Type: NE-SA40

Class: Thermo-Kinetic Stealth Ultra-Light Power Armor Suit.

Crew: One.

M.D.C. by Location:

- * Head/Helmet – 65
- * Hands (2) – 15 each
- Arms (2) – 55 each
- Legs (2) – 70 each
- ** Main Body – 220

* A single asterisk indicates a small and/or difficult target to strike, requiring the attacker to make a “called shot” to hit them, but even then the attacker is -4 to strike.

** Depleting the M.D.C. of the main body shuts the armor down completely, making it useless and leaving the pilot inside vulnerable to future attacks. Depleting the M.D.C. of the helmet/head eliminates all forms of optical enhancements, sensory systems and targeting, and forces the pilot to rely on his own human senses. It also eliminates any power armor combat bonuses. The Black Fist armor is too thin and light to wear a Cermalyte suit under it.

Speed:

Running: 50 mph (80 km) maximum. Note that running does tire the user, but at 20% the usual fatigue rate, thanks to the exoskeleton.

Leaping: The powerful robot exoskeleton’s legs can propel the lightweight armor suit 20 feet (6.1 m) high or lengthwise from a standing start, add 15 feet (4.6 m) with a short running start.

Underwater Capabilities: **Swimming:** The wearer can swim underwater or on the surface at double his normal swimming speed. Maximum Ocean Depth: 2000 feet (610 m).

Statistical Data:

Height: +4 inches (0.1 m) taller than the wearer; adjustable to fit anybody between 5 and 7.5 feet (1.5 to 2.28 m).

Width: Approx. 2 feet (0.6 m) from shoulder to shoulder; varies with the size and bulk of the pilot.

Length: Approx. one foot (0.3 m); varies with the size and bulk of the pilot.

Weight: 100 lbs (45 kg).

Physical Strength: Equal to a Robotic P.S. of 25.

Cargo: None.

Power System: NE-EB electrical battery good for 96 hours of continuous use. The NE-EB-A is the standard, all-purpose electrical battery (typically just referred to as the NE-EB) used to power other types of Body Armor and weapon systems. It is an alternative to the much more expensive nuclear battery/power supply and is reusable; requires two or three hours to recharge depending on the quality of the recharging facility (anyplace that can recharge an E-Clip or that can tap into a nuclear power supply). The NE-EB costs 100,000 credits and at least one spare is recommended.

Cost: 3.8 million credits with one NE-EB battery included, and worth every credit.

Weapon Systems: None. The wearer is forced to rely on handheld weapons, including most rifles, light rail guns, Naruni plasma cartridge weapons, and others suitable for use by cyborgs or power armor. All weapons must have their own independent power supply and cannot be connected to the suit’s internal battery.

Hand to Hand Combat Damage: Rather than use a weapon, the pilot can engage in Mega-Damage hand to hand combat.

Restrained Punch: 6D6 S.D.C.

Normal Punch: 1D4 M.D.

Power Punch: 2D4 M.D., but counts as two melee attacks.

Kick: 1D6 M.D.

Leap Kick: 2D6 M.D., but counts as two melee attacks.

Robot Combat & Piloting Bonuses: +2 on initiative, +1 to strike, parry and dodge at levels 1, 6 and 12, +1 attack per melee round at levels 1, 4, 8, 12 and 15. +15% to Prowl and +5% to Conceal thanks to the combined sensors and features described below.

Sensors & Features of Note: 1. Stealth System: For maximum stealth the NE-SA40 incorporates the utmost in sensor-defeating technologies. The suit is composed of radar absorbing materials, and has a minimized radar cross signature about the size of a house cat (there's only a 01-20% chance of being detected by radar at all).

2. Advanced Internal Cooling System: There are also IR suppressors and an internal electronic cooling unit to make the heat signature of the suit and the pilot inside match the ambient air temperature, making him, effectively, invisible to heat sensors, thermo-imagers and infrared optics (cannot be detected unless within two feet/0.6 m of the heat sensor, and then there is only a 01-10% chance). **Note:** This system can only run for two hours at a time before requiring a down period of one hour. These features combine to make the suit almost impossible to detect with sensory equipment under normal circumstances; attempts to locate the armor suit using radar, thermal-sensors/heat detectors (cannot be detected by thermal-imaging at all) and similar sensory devices incurs a -70% penalty to the operator's Read Sensory Equipment skill.

3. Thermo-Kinetic Armor: Provides all the bonuses and protection of this revolutionary material, exclusive to Naruni Enterprises (see the opening section to Body Armor for details).

4. HUD Visor: A Heads Up Display that can project data, charts, topographical maps, orders and mission information, or transmissions on the visor of the helmet for the wearer to see. As many as six different HUD viewing sections/images can be projected without impairing the vision of the wearer.

5. Optical Enhancements: Optics package includes telescopic (up to 10x magnification, range is 2 miles/3.2 km), passive nightvision (3000 foot/914 m range), and thermal-imaging (1500 foot/457.2 m range).

6. Integrated Sensor Pod: This sensor suite is a multi-dimensional, threat awareness system that provides the user with a heightened level of perception concerning his surroundings. It consists of a motion detector and mini-radar with 360 degree scanning capability. Threats are indicated on the HUD visor by flashing red icons. The pod provides bonuses of +3 on initiative, +2 to parry and dodge, +5 to roll with impact or fall, and allows the wearer to dodge all attacks, even those from behind and/or surprise.

NE-1A-TWPA

Tech-Warrior Power Armor

Want a suit of power armor with a range of special features unlike other suits offered by other manufacturers? Want to make a fashion statement to boot? Then you want to take a close look at Naruni Enterprises' Tech-Warrior Power Armor.

On a stylistic note, the Tech-Warrior is designed to a different style than most high-tech armor and has a rather retro appearance. This is done, in part, to trick and confuse opponents who may be lulled into a false sense of security by the look of the armor. With that in mind, the power armor's flight wings are retractable (shown retracted in the illustration). Each Tech-Warrior power armor comes with its own individually designed helmet – no two helmets look the same and the owner can make his own, personal statement. Custom airbrush artwork for the body of the armor is also available from our on-staff artists at a cost of 25 credits an hour.

Though the Tech-Warrior may look different and a bit low-tech, it is superior to most power armor offered in North America. First, it has a dual-protection system that combines one or our best force fields overlaid on top of a heavily armored suit. A variable camouflage system and a contra-gravity flight system are also exclusive to Naruni power armor.

As for weapons, the Tech-Warrior can unleash a powerful electric blast from a concealed discharger built into each arm, ion blaster "eyes" (actually fired from a low profile weapon nozzle on the side of each eye, built into the helmet) hammer opponents at close range, and a Ripper Vibro-Sword with a straight-edged knightly design is provided for keeping with that retro "medieval" styling and appeal. The last combat features of note are a powerful photon-flash generator in the forehead that produces a "Blinding Flash," and silver plating on the hands, elbows, parts of the shoulders and helmet so they can strike supernatural beings vulnerable to the metal (does 1D6 damage to them).

Model Type: NE-1A-TWPA Tech-Warrior Power Armor.

Class: Medium All-Purpose Strategic Power Armor.

Crew: One.

M.D.C. by Location:

Shoulder Mini-Missile Launchers (2; flip-top) – 110 each

Forearms (2) – 100 each

Hands (2) – 30 each

Legs (2) – 200 each

Feet (2) – 90 each

* Head – 120

** Main Body – 350

*** NE-F50A Super-Heavy Force Field – 160

* Destroying the M.D.C. of the head/helmet has a 01-70% chance of knocking the pilot unconscious. If conscious, the pilot has two problems: one, no power armor combat bonuses, and two, the pilot's own head is now vulnerable to attack. However,

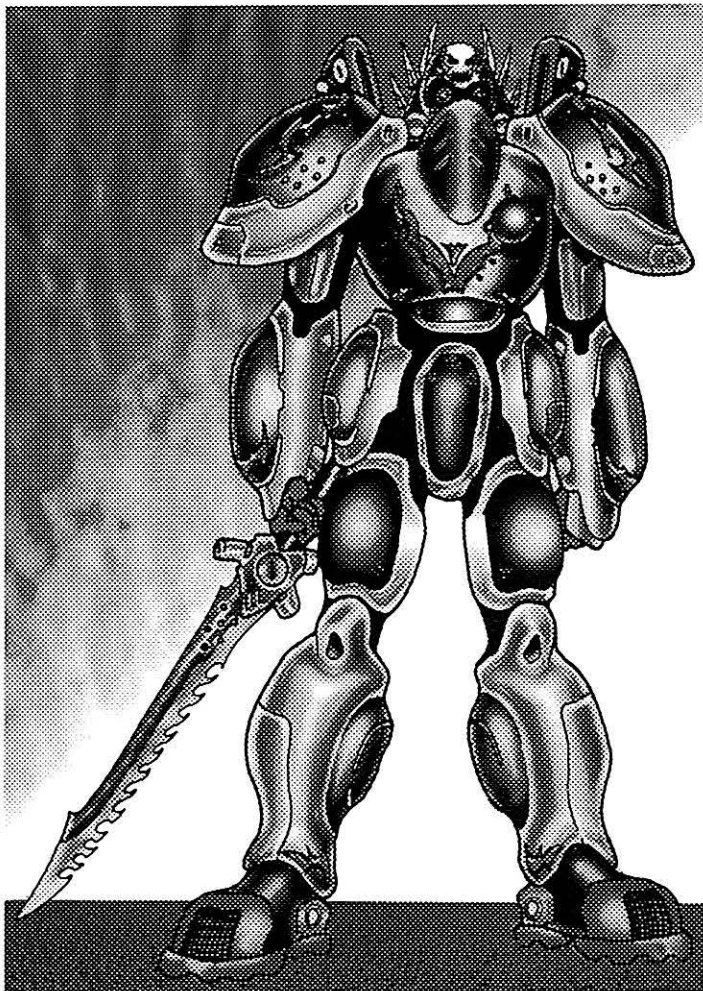

the head is a small target protected by a high neck cowl, the shoulder plating and the tops of the folded wings on the back. Thus, it can only be hit when a character makes a "called shot," and even then the attacker is -5 to strike. -4 to shoot the hands.

** Depleting the M.D.C. of the main body will shut the armor down completely, and the pilot will be vulnerable to attack. Also see force field.

*** Typically the force field is engaged to protect the main body. If the M.D.C. of the force field is depleted, it cannot be re-activated again for 24 hours. As long as the force field's M.D.C. has not been reduced to zero, it regenerates lost M.D.C. at the rate of 1D4 points per minute.

Speed:

Running: 60 mph (96 km) maximum. The act of running does tire out the operator, but at only 10% of the normal fatigue rate thanks to the robot exoskeleton.

Leaping: The powerful robot legs can leap up to 15 feet (4.6 m) high or across unassisted by the flight system. A contra-gravity assisted leap can propel the armor up to 100 feet (30.5 m) high and 200 feet (61 m) across without actually attaining flight.

Flying: Contra-gravity system allows for flight at up to 200 mph (320 km) in an atmosphere, or Mach One (670 mph/1072 km) in outer space. The contra-gravity system enables the Tech-Warrior to hover in stationary position at any altitude desired.

Maximum Altitude: Unlimited. The contra-gravity system allows the suit to escape a planet's atmosphere and fly out of orbit. Of course, doing so is a death sentence from Earth.

Underwater: Maximum speed of 50 mph (80 km) using the contra-gravity system, or as per swimming skill using one's limbs.

Maximum Depth Tolerance: 2000 feet (610 m).

Maximum Range: Unlimited. The contra-gravity system does not overheat. The only limit is the pilot's endurance.

Statistical Data:

Height: About one foot (0.3 m) taller than the wearer (each suit is adjusted to the height of the pilot), depending on the design of the helmet. Some helmets have truly large adornments and can add as much as 2 feet (0.6 m) to the height of the power armor and may protrude from the side of the head as well. The elaborate helmets can have various fins, crests, spikes, spines, horns, antlers, and even statues mounted on them.

Width: 4 feet (1.2 m) because of the wide shoulders and wings (when retracted). Wings fully extended: 11 feet (3.3 m).

Length: 3 feet (0.9 m).

Weight: 1,200 lbs (5440 kg).

Physical Strength: Equal to a Robotic P.S. 32.

Cargo: None.

Power System: Nuclear; average energy life of 20 years.

Cost: 8.6 million credits.

Weapon Systems:

1. **Shoulder Mini-Missile Launchers (2):** The heavily armored and oversized shoulder plates conceal mini-missile launchers. To fire, the tops of the armor plating flip up and unleash the missiles.

Primary Purpose: Anti-Aircraft/Anti-Robot/Anti-Missile.

Secondary Purpose: Ground or Air Assault.

Mega-Damage: Varies with type. Any mini-missile can be used, but standard issue is armor piercing (1D4x10 M.D.), and high explosive or fragmentation (5D6 M.D.), with an even mix of both. Fragmentation missiles are used for anti-personnel operations.

Range: Usually about a mile (1.6 km).

Rate of Fire: One at a time or a volley of two, three, four, or six.

Payload: 16 total, eight in each shoulder launcher.

2. **NEL-11 "Lightning" Electrical Arc Discharger (2):** One is hidden in each arm, with no visible firing ports. This unique weapon fires a powerful electrical energy bolt that not only inflicts Mega-Damage, but affects enemy aircraft, robots, vehicles or power armor, or stuns humans (even through body armor) and other living creatures.

Primary Purpose: Assault and Anti-Electronics.

Secondary Purpose: Defense.

Mega-Damage: 4D6 M.D. per electrical blast, plus unshielded electronics (including sensor systems, computers, communications equipment, etc.) that are not destroyed when struck by an electrical blast directly will be scrambled for 1D6x10 minutes and are likely to require some fussing and work to get them back on-line. **Note:** Light power armor, light and medium body armor, open vehicles, and light vehicles may also suffer additional damage and side effects (G.M.'s option). See the Optional Lightning Side Effect Table. Heavy power armor and A.I.s, as well as armored vehicles and robot vehicles with a reinforced pilot's compartments are insulated and will protect the pilot, crew and internal electronics completely.

Rate of Fire: Each blast counts as one melee attack/actions.

Range: 1000 feet (305 m).

Payload: Effectively unlimited.

Bonus: +1 to strike.

Optional Lightning Side Effects Table:

01-15% Lucked out! No additional problems or side effects.

16-30% The instrument panel blinks out and sparks fly. It snaps back online 1D6 seconds later, but the crew loses the initiative (if they had it) and one melee attack. This may give their opponent the opportunity to escape or strike again before they have a chance to respond.

31-45% All weapon systems are temporarily out and there are minor electrical fires! One comes back online every 1D4 melee rounds (15 to 60 seconds).

46-60% Radar and targeting systems are gone for 2D6 minutes. Line of sight visuals until they come back. No power combat bonuses provided by the armor or vehicle, and -15% on the piloting skill.

61-75% Communications is knocked out for 4D6 minutes.

76-85% Sensors and radar are gone and all instrument readings are unreliable for 6D6 minutes. The pilot must fly strictly on sight with a penalty of -25% when speed is one-third of the maximum possible, -50% at half maximum speed, and -75% at full speed. No initiative and no combat bonuses provided by the power armor or vehicle.

86-90% Fried circuits! All weapon systems are locked and do not respond. Requires physical repairs, parts and an hour's labor by an Operator to get them operational. Take evasive action.

91-95% Fried circuits! All sensors and radar are gone. Same penalties as #76-85%, only systems will not come back up. Requires physical repairs, parts and an hour's labor by an Operator to get them operational. Take evasive action.

96-00% Engine trouble. Maximum speed is reduced to 10% of normal and power armor and aircraft will not be able to maintain flight. Make emergency landing and take 1D6x10 M.D. in a rough (but not quite crash) landing. No bonuses to dodge and -2 on initiative.

3. Ion "Eye" Beams (2): Mounted in the helmet on each side of eyes is a light ion blaster. They may be fired one at a time or both simultaneously at the same target. Line of sight targeting means wherever the pilot looks the ion blasters can shoot.

Primary Purpose: Self-Defense and close combat.

Mega-Damage: 2D6 M.D. per single eye beam, or 4D6 if both eye beams are fired simultaneously.

Rate of Fire: Each single or double blast counts as one of the pilot's melee attacks.

Range: 500 feet (152 m).

Payload: Effectively unlimited.

Bonus: +1 to strike.

4. Knight's Ripper Vibro-Sword (1): A large, two-handed Ripper Vibro-Sword is carried in a scabbard on the left side (or right side for left-handed warriors). This Vibro-Sword also comes with the standard silver coating for dealing with supernatural menaces.

Primary Purpose: Close Combat.

Secondary Purpose: Anti-Supernatural.

Mega-Damage: 3D6 M.D.

Range: Close combat; extends reach by four feet (1.2 m).

Bonus: As per the W.P. Sword skill only.

5. "Blinding Flash" Photon-Flash Generator (1): The photon-flash system creates a sudden burst of intense, white light that can temporarily blind everyone within 20 feet (6.1 m) in front of the power armor.

Primary Purpose: To surprise, create confusion and blind opponents not shielded from light.

Secondary Purpose: Self-Defense.

Mega-Damage: None, but victims need to roll a 16 or higher to save vs temporary blindness (apply any P.E. attribute bonus to save). A failed save means the character is blinded for 1D6 melee rounds, with a penalty of -10 to strike, parry and dodge. The chance of falling is 01-50% for every 10 feet (3 m) traveled, 01-80% if running. Those who successfully save suffer no penalty except -1 on initiative. Blinding Flash does not affect bionic or cybernetic eyes.

Rate of Fire: Once per melee round and counts as one melee attack/action.

Range: 20 feet (6.1 m).

Payload: Effectively unlimited.

6. Variable Camouflage System: The suit's skin is covered by a fiber-optic nano-tech material that can change colors to match the general environment. Color change takes 1D4 melee rounds (15 to 60 seconds), in which the armor becomes the exact same color as the predominant one in the area. In the woods or in broken terrain, the suit will be streaked or striped to represent light and shadow as lighter and darker colors like a camouflage pattern. In all cases, the wearer is difficult to spot: -20% for others to Detect Ambush and Detect Concealment when the pilot is under cover, +5% to the wearer's Prowl skill, and even characters without Prowl have a 40% chance of not being seen if they stay under cover and don't move. The system also masks infrared and thermal emissions, making the wearer's heat invisible to infrared and thermal optics. There is only a 01-25% chance of the suit showing up on thermal systems and even then the reading/image will seem unusual, unclear and unidentifiable. The variable camouflage system is disabled after the armor's main body takes 280 points of damage.

7. Radar Jammer: Additionally, the pilot can activate a radar/sensor jammer and "spoofer" for dealing with high-tech enemies. While the jammer is on, conventional radar and missile guidance systems will not be able to "tag"/target the power armor – missiles are -8 to strike and attacks by other ranged weapons will require line of sight on the part of the attacker who fires without benefit of targeting systems or radar. The jammer has a one mile (1.6 km) radius range. Leaving it on all the time will automatically alert the enemy that a jammer-equipped vehicle is in the area, however, so standard operational procedure is not to activate it until combat is underway, or just before attacking.

8. Hand to Hand Combat: Rather than use a weapon, the pilot can engage in Mega-Damage hand to hand combat.

Damage and Bonuses from Tech-Warrior PA Combat Training:

Restrained Punch: 1D4 M.D.

Full Strength Punch: 2D4 M.D.

Power Punch: 4D4 M.D.

Kick: 2D6 M.D.

Leap Kick: 4D6 M.D.

Body Flip/Throw: 1D4 M.D. plus loses one melee attack/action.

Body Block/Ram: 1D6 M.D. and has a 01-65% chance of knocking one's opponent off his feet (if successful, the target loses the initiative and one melee attack/action), but counts as two melee attacks.

Note: May use other handheld weapons available to the character.

Bonuses: +1 to initiative, +2 to strike, +3 to parry, +1 to dodge, +1 to roll with impact, +1 to disarm, and +2 to pull punch. +2 to dodge while flying, and +1 melee attack at levels 1, 5, 10 and 15.

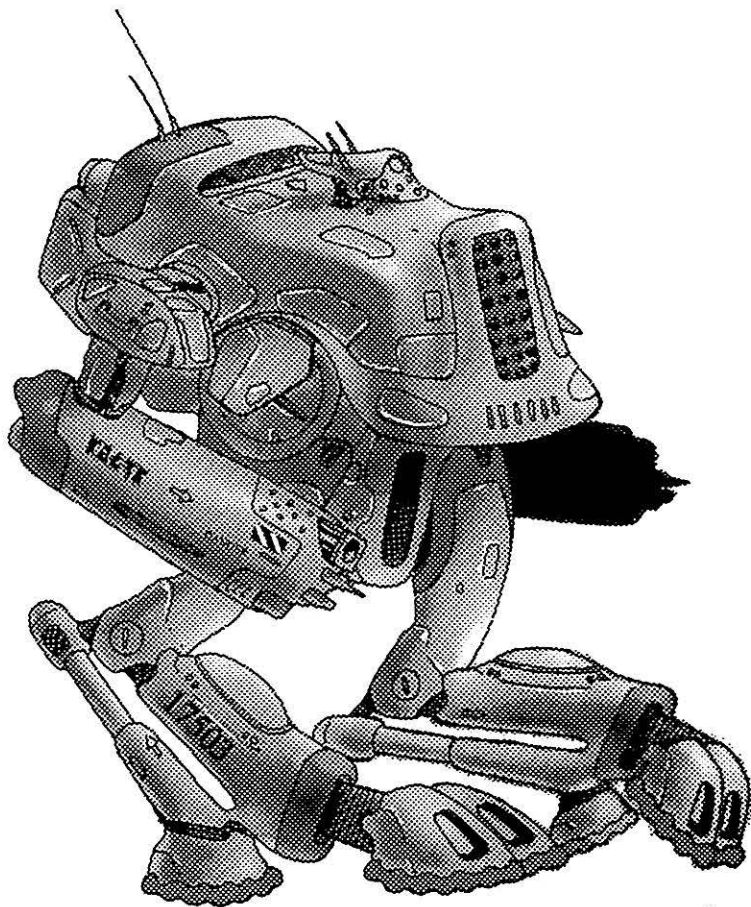

NE-DXZ-07 "Razor" Heavy Power Armor

The Razor Heavy Power Armor may remind people in North America of the Coalition IAR-5 Hellfire, but the Razor has been used for centuries in the Phase World dimension. The legs are bird or "ostrich" style, though the large feet make the armor extremely stable even on gravel or loose dirt and when climbing uneven surfaces. For arms, the Razor has a pair of multi-weapon platforms giving it impressive and versatile firepower. The entire upper body can rotate 360 degrees, so the Razor can spin to face an enemy to its side or from behind without having to move its legs. The ostrich-like legs and sleek, compact body actually give

the Razor a low profile and good speed, even leaping capabilities. Some feel that the Razor is not a power armor at all, but a super-sophisticated, miniaturized robot. Most consider it to be power armor, because it is a one-man robot and is super light (3 tons) when compared to most robot vehicles. However, the pilot does sit at a control console and the armor is completely automated.

We invite buyers to pit the Razor against the Coalition Hellfire – we think it's a match up you'll enjoy.

Model Type: NE-DXZ-07 Razor Heavy Power Armor.

Class: Strategic Urban Assault Suit.

Crew: One.

M.D.C. by Location:

Main Mini-Missile Launcher (1; nose) – 160

*Secondary Mini-Missile Shoulder Launchers (2; small) – 50 each

*Secondary Mini-Missile Leg Launchers (2; small) – 60 each

Multi-Weapon Forearms (2) – 210 each

Upper Arms (2) – 100 each

Legs (2) – 180 each

Feet (2) – 100 each

*Rear Booster Jets (4) – 30 each

Reinforced Pilot's Compartment – 120

**Sensor Pod (top) – 50

***Main Body – 570

* A single asterisk indicates a small and/or difficult target to strike, requiring the attacker to make a "called shot" to hit them, but even then the attacker is -4 to strike.

** Destroying the sensor pod of the power armor will eliminate all forms of optical enhancement and sensory systems. The pilot must now rely on his own human vision and senses, looking through a small view port in the armor's chest. No power armor combat bonuses to strike, parry or dodge. **Note:** The sensor pod is a small and difficult target to hit, shielded by the shoulder plating. Thus, it can only be hit when a character makes a called shot and even then the attacker is -4 to strike.

*** Depleting the M.D.C. of the main body will shut the armor down completely, making it useless.

Destroying all four of the booster jets reduces the maximum speed to 90 mph (144 km), eliminates thruster assisted leaps, and inflicts a penalty of -1 to dodge. Destroying two of the thrusters only reduces the leaping distance by 40%.

Speed:

Running: 120 mph (192 km) maximum. Note that the act of running does NOT tire out its operator. Cruising speed is a more cautious 60 mph (96 km). Well suited for most terrains, including mountainous terrain, with rear booster jets to keep the power armor stable and moving forward as well as to assist in leaping and against concussions from enemy bombardment.

Leaping: The powerful robot legs can leap up to 15 feet (4.6 m) high or across unassisted by the thrusters. A jet thruster assisted leap from a stationary position can propel the unit up to 40 feet (12.2 m) high and across, double with a running start.

Underwater: Maximum speed of 50 mph (80 km) using the booster jets, or as per swimming skill using the robot's arms and legs.

Maximum Depth Tolerance: 2000 feet (610 m).

Flying: Not possible! The rear rocket system is provided to enhance leaping, as well as to add balance and stability, nothing more.

Statistical Data:

Height: 18 feet (5.5 m) from head to toe.

Width: 9 feet (2.7 m).

Length: 6 feet (1.8 m).

Weight: 3 tons (2700 kg).

Physical Strength: Equal to a Robotic P.S. 40.

Cargo: Small area for the pilot's personal items, as well as a weapon bin that has room for one rifle, one pistol, light body armor, and canteen and food rations (4 week supply). A two gallon (7.6 liter) water cooler is built into the unit.

Power System: Nuclear; average energy life is 20 years.

Cost: 18 million credits, the cost of the mini-missiles varies and they are sold separately.

Weapon Systems:

1. Multiple Mini-Missile Integrated Launcher System (1):

The Razor has a series of mini-missile launchers built into it, with 48 mini-missiles in its main launcher (nose), six concealed in each of its spindly looking upper arms, and 8 mounted in each of its large lower leg launchers (the bubble on the lower leg). All five launchers are integrated into one massive, interconnected launching system.

Primary Purpose: Anti-Aircraft/Anti-Robot/Anti-Missile.

Secondary Purpose: Assault and Defense.

Mega-Damage: Varies with mini-missile type. Any mini-missile can be used, but standard issue is armor piercing (1D4x10 M.D.) or plasma (1D6x10 M.D.). Fragmentation and high explosive (both doing 5D6 M.D.) are reserved for anti-personnel operations.

Range: Usually about a mile (1.6 km).

Rate of Fire: One at a time or a volley of two, three, four, six, eight or twelve.

Payload: 76 total, 48 in the nose, six in each shoulder and eight in each lower leg.

2. Multi-Weapon Forearms (2): The Razor's pure combat design is most evident in its forearm weapon platform with its multiple weapons. The forearm can rotate at the elbow as well as rotate up and down 360 degrees to strike at enemies up, down and from all sides.

Primary Purpose: Assault.

Secondary Purpose: Defense.

Mega-Damage: The four weapon systems are as follows:

a) Plasma Cartridge Rifle: 5D6 M.D.; a controlled three round burst does 1D6x10 M.D.; fires the "Medium" NE-002PC round.

b) Combat Laser: Two settings: 3D6 M.D. or 5D6 M.D.

c) Medium Particle Beam: 1D4x10 M.D. per particle beam blast.

d) Plasma Ejector: 5D6 M.D. per single blast.

Rate of Fire: Each weapon blast and burst counts as one melee attack, as does a missile volley. Only one type of weapon can be fired, per weapon arm, at a time, but the Multi-Weapon Platform offers an amazing array of combat choices and both arms can be aimed and fired simultaneously at the same target doing si-

multaneous damage from each arm. However, the Razor forfeits its power armor combat bonuses when it does so.

Range: Mini-missiles: One mile (1.6 km). Laser: 2000 feet (610 m). All others have a range of 1200 feet (366 m).

Payload Weapon Arms (2): Standard Plasma Cartridge Rifles: 320 round internal magazine (120 bursts) for each arm. Energy weapons (laser, particle beam and plasma) are each effectively unlimited.

3. Hand to Hand Combat: Rather than use a weapon, the pilot can engage in Mega-Damage hand to hand combat, using the weapon arms as a hammering bludgeon and the large feet to kick and stomp.

4. Damage & Bonuses from Razor Heavy Power Armor Combat Training: Taking Power Armor Combat: Elite for the Razor PA automatically gets Robot Combat: Elite for the Hammer Robot, due to their nearly identical designs (only the size differs). The Razor can still punch with its multi-weapon forearms, even though it does not have hands.

Restrained Punch: 1D6 M.D.

Full Strength Punch: 2D6 M.D.

Power Punch: 4D6 M.D.

Kick: 3D6 M.D.

Leap Kick: 6D6 M.D.

Stomp: 1D6 M.D., but only usable on targets 6 feet (1.8 m) tall or smaller.

Body Block/Ram: 2D6 M.D. and has a 01-75% chance of knocking one's opponent off his feet (if successful, the target loses the initiative and one melee attack/action), but counts as two melee attacks.

Bonuses: +1 to initiative, +2 to strike and parry, +2 to dodge, +2 to roll with impact, and +2 melee actions/attacks at level one and +1 additional attack per melee at levels 1, 5, 9, and 14.

NE-PA003 "Drudge" Industrial Power Armor

Naruni Enterprises has been around for centuries selling the Megaverse's best arms and equipment, but what many people don't know is that one of our earliest successes was in the design and manufacture of haulers and construction equipment. Naruni Enterprises has gotten out of the industrial equipment business, but one of the holdovers from those early days is the all-purpose "Drudge" Industrial Power Armor. Originally designed with heavy lifting, hauling and construction in mind, no thoughts were given to armor or weapons. The Drudge is basically a workhorse of power armor. The standard model comes without weapons, though it can be customized to have as many as four light to medium weapons added to its frame, typically the forearms and shoulders. Although not designed for combat, the Drudge is suitable for exploration and basic defense. It can more than hold its own in hand to hand combat, its formidable strength, grip and leverage making it superior to most other power armor and small robot vehicles in a punching or wrestling match.

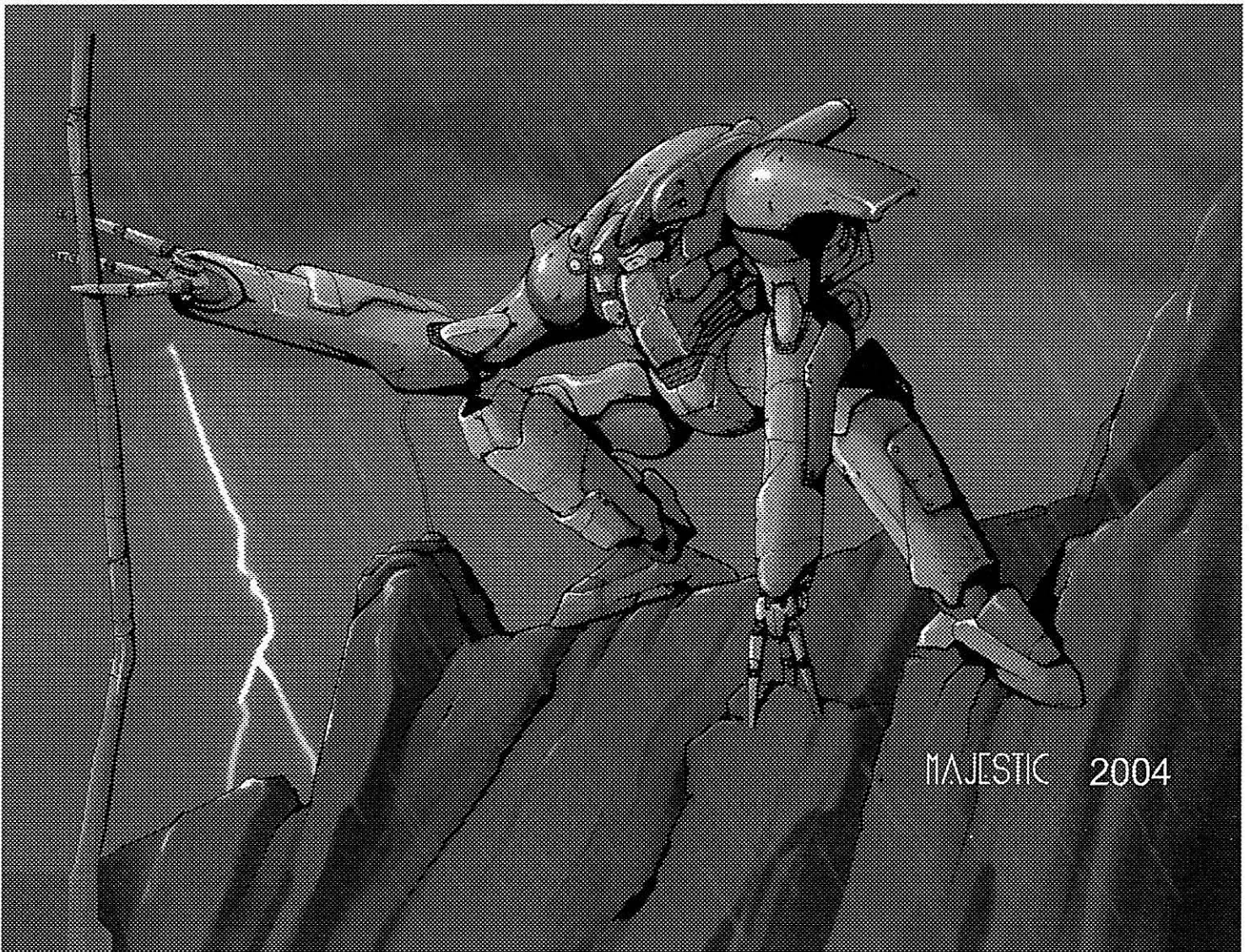

The original Drudge was built along the lines of an open-framed exoskeleton, with industrial armor enclosing those areas most likely to be hit in a construction accident. For instance, the original Drudge did not have a helmet but an overhead shield to prevent the pilot from being hit on the head by falling debris. It also had three vulnerable areas where portions of the pilot's body were exposed, requiring the operator to wear light Mega-Damage body armor, like the Cermalyte, for additional protection. (Game Note: For anyone who might acquire an original Drudge, the following were opened areas where the body was vulnerable to attack: 1. The arms: An attacker must make a called shot and even then is -3 to strike. 2. The legs: An attacker must make a called shot and even then is -4 to strike. 3. The head: An attacker must make a called shot and even then is -5 to strike.) HOWEVER, the classic Drudge has been upgraded for the Earth market with additional armor plating and stylization to enclose and protect the pilot.

Model Type: NE-PA003 "Drudge" Industrial Power Armor.
Class: Industrial Powered Exoskeleton Suit.
Crew: One.

M.D.C. by Location:

- Arms (2) – 200 each
- Hands (2) – 100 each
- Legs (2) – 200 each
- Feet (2) – 100 each
- *Sensor Cluster (head) – 50
- **Main Body – 400

* Destroying the sensor cluster of the power armor will eliminate all forms of optical enhancement and sensory systems. The pilot is left to rely on his own human vision and senses, and loses any bonuses provided by the unit. The sensor cluster is a small and difficult target to hit. Thus, it can only be hit when an attacker makes a "called shot" and even then he is -4 to strike.

**Depleting the M.D.C. of the main body will shut the armor down completely, making it useless.

Speed:

Running: 40 mph (64 km) maximum, this power armor is designed for labor, not speed. Note that the act of running tires out its operator at 10% the normal fatigue rate. Well suited for most terrains, including mountainous terrain, as the powerful arms are good at climbing.

Leaping: Not possible.

Underwater: The Drudge can perform underwater labor and construction, but needs to be transported to the work site. The power armor can walk along the bottom of waterways at 20 mph (32 km), but it sinks like a stone and cannot swim.

Maximum Depth Tolerance: 2000 feet (610 m).

Flying: Not possible.

Statistical Data:

Height: 16 feet (4.9 m) from head to toe.

Width: 8 feet (2.4 m).

Length: 4 feet (1.2 m).

Arm Length: 10 feet (3 m); the Drudge has extra long forearms (and long slender fingers) to better enable the machine to lift and carry large loads, as well as to provide an extended reach and help with climbing.

Weight: 5 tons.

Physical Strength: Equal to a Robotic P. S. 50.

Cargo: Large storage area for the pilot's personal items, as well as a weapon bin that has room for three or four rifles, several pistols, a heavy weapon or two, a set of body armor, and canteen and food rations (4 week supply).

Power System: Nuclear; average energy life is 10 years.

Cost: A bargain at only 1.9 million credits.

Weapon Systems:

1. None, although the operator could carry any type of rifle or gun designed for large humanoids or giant robots (the Drudge has big hands).

2. **Hand to Hand Combat:** Rather than use a hand weapon, the pilot can engage in Mega-Damage hand to hand combat.

Damage and Bonuses: Note there is no Elite Robot Combat Training for the Drudge, but with Basic Robot Combat Training the operator of the Drudge Industrial Power Armor can use the following bonuses:

Restrained Punch: 1D6 M.D.

Full Strength Punch: 3D6 M.D.

Power Punch: 1D6x10 M.D.

Kicks are not possible.

Stomp: 2D6x10 M.D., but only usable on targets less than 8 feet (2.4 m) tall.

Body Block/Ram: 6D6 M.D. and has a 01-90% chance of knocking one's opponent off his feet (if successful, the target loses the initiative and one melee attack/action), but counts as two melee attacks.

Bonuses: +1 to strike, +2 to parry, +1 to dodge, +3 to pull punch, and +1 melee attack at levels 1, 6, and 12.

NE-X4-LH "Sun Chariot"

Experimental Power Armor

One of the greatest pleasures of being a Naruni Enterprises sales representative is being able to bring cutting-edge technology to our customers. So it is that we present the latest in style and innovation, the new Sun Chariot Power Armor. Still in the experimental testing stages, Naruni Enterprises has produced a few thousand of these real gems for sale at below cost to be field tested on the streets and battlefields of Earth.

The Sun Chariot is an experiment in transformable robot suits. In this case, a roughly man-sized power armor that is also a land speeder of unusual design. The pilot can fold and tuck the Sun Chariot into a fetal position with the forearms, lower legs, feet, head and back locking in place to form a wheel configuration. The outer perimeter of the wheel is concealed in armor configuration, but once it locks itself together, the wheeled mode of the power armor is able to roll at great speeds like a high-tech unicycle. The beauty of it is that the pilot is completely contained within the armor so there is no apparent driver to be shot at or to get knocked off his motorbike. (The pilot navigates by instruments and video monitors inside the armor, manipulating controls like a motorcycle from inside.) Furthermore, the vehicle is so low profile and fast that it is difficult to hit when shot at, and most people seeing it for the first time have no idea what it is or how to react – at least until it transforms into a human-shaped suit of power armor. And as if that weren't wild enough by itself, once rolling as a speeding unicycle, the Sun Chariot automatically releases vapors that make it appear to be on fire. Actually, the flame is a plasma field generated similar to the Kittani's Plasma Harness. Designed for dramatic effect, the plasma field has been carefully engineered NOT to set fire to the countryside as it barrels across the landscape. However, the plasma field does provide some level of additional protection, because anyone who grabs or leaps on top of a Sun Chariot is burned (2D6 M.D. per melee round) and temporarily blinded by the burning plasma vapors (blind the entire time he is holding on and 1D6 melee rounds after letting go; -10 penalty on all combat rolls when blind). **Note:** When traveling in "chariot" configuration, the "wheel" revolves on its own, under the pilot, he does not spin with it like a tumbleweed.

The new Sun Chariot is made possible through an integration of advanced gyroscopic balancing systems, our new, patented, Thermo-Kinetic Armor and a series of heat baffles that make the power armor impervious to heat, and the plasma field it generates when in locomotion. The Sun Chariot is armed with a selection of plasma based weapons, including a heavy plasma cartridge weapon on both forearms, a complement of plasma mini-missiles and a "Dragon's Breath" plasma ejector built into the helmet. The Sun Chariot can only produce the plasma field in "chariot" configuration, but can erect a light force field in humanoid or "armor" configuration (the force field is not available as a rolling fire ball). Burststers and pyromaniacs find the Sun Chariot desirable, but nobody loves it as much as speed freaks and adventurers with a flare for the flamboyant. Robot pilots looking for something truly different in power armor needn't look beyond the



incomparable Sun Chariot. Get yours before the testing stage is done and the sticker price goes from 3.3 million credits to 12 million.

Model Type: NE-X4-LH Sun Chariot Power Armor.

Class: Experimental Combat Powered Armor Suit.

Crew: One.

M.D.C. by Location:

Forearm Plasma Cartridge Weapons (2; round shields) – 80 each

Chest mounted Mini-Missile Launcher (1) – 100

Retractable Vibro-Swords (2, one per forearm) – 100 each

Forearm Shields – 120 each

Arms (2) – 100 each

Hands (2) – 50 each

Legs (2) – 160 each

Feet (2) – 60 each

*Head/Helmet – 100

**Main Body – 320

***NE-F10A Light Force Field – 60 (available in “armor mode” only).

* Destroying the head/helmet has a 01-70% chance of knocking the pilot unconscious. Staying conscious has its own problems: The pilot loses all combat bonuses provided by the armor, no access to sensors, his head is now vulnerable to attack, and the Sun Chariot can no longer use “chariot mode” or the “Dragon’s Breath” attack. **Note:** The head (and hand) is a small and difficult target to hit. Thus, it can only be hit when an attacker aims and makes a “called shot,” and even then he is -4 to strike.

**Depleting the M.D.C. of the main body will shut the armor down completely, making it useless in both modes of operation.

*** If the M.D.C. of the force field is depleted, it cannot regenerate and reactivate again for 12 hours. As long as the force field’s M.D.C. has not been depleted, however, it regenerates lost M.D.C. at the rate of one point per minute (that’s 60 M.D.C. an hour). An overloaded force field can be activated at full strength (all M.D.C.) after the 12 hour delay has expired.

Remember: The Sun Chariot is made out of Thermo-Kinetic alloy and has a series of heat baffles that make it impervious to fire and heat (including magical fire); no damage. The Sun Chariot also reduces all damage from physical impacts, high speed collisions, explosives, missiles, and most projectile weapons by half.

Speed:

Running: Can run at up to 70 mph (112 km) maximum. Note that the act of running does tire out the operator, but at only 30% of the normal fatigue rate, thanks to the robot exoskeleton.

Chariot Speed: As a wheeled vehicle, the Sun Chariot can reach an impressive ground speed of 400 mph (640 km) and does not tire its pilot (same as riding a crotch rocket motorcycle or rocket bike).

Leaping: The powerful robot legs can leap up to 20 feet (6.1 m) high or across, twice that distance with a running start. A leap is not possible in chariot config.

Underwater: Not possible! Being submerged for more than five minutes causes severe damage. The experimental systems react

badly to water, blowing out the chariot configuration and the transforming ability of the armor.

Flying: Not possible.

Statistical Data:

Height: 8 feet (2.4 m).

Width: 6 feet (1.8 m), from shoulder to shoulder.

Length: 3.5 feet (1.06 m).

Weight: 600 lbs (270 kg).

Physical Strength: Equal to a Robotic P.S. 24.

Cargo: None.

Power System: Nuclear; average energy life of 5 years, still experimental and draws too much energy.

Cost: As an experimental unit the cost is just 3.3 million credits. (Tolkeen resistance forces are snapping them up as fast as they can lay their hands on them, so have some mercenary companies).

Weapon Systems:

1. **Plasma Cartridge Forearm Weapons (2):** These weapons use Naruni NE-003PC “Standard” Plasma Cartridges and are the equivalent of having two built-in Naruni heavy plasma cartridge rifles.

Primary Purpose: Assault.

Secondary Purpose: Defense.

Mega-Damage: 1D4x10 M.D. per single shot, or 2D4x10 M.D. for a twin forearm shot.

Rate of Fire: Each single or dual shot counts as one melee attack.

Range: 1200 feet (365 m).

Payload: 120 shot internal magazine per arm (60 dual two-shot bursts per arm). There has been some consideration about going with the medium or even the micro-Plasma Cartridges to double or triple the payload, though damage would be less (5D6 and 1D6x10, or 3D6 and 6D6 respectively).

2. **Chest Mounted Mini-Missile Launcher (1):** The chest launcher comes from the factory armed with plasma mini-missiles, but any kind of conventional mini-missile can be used in the launcher.

Primary Purpose: Anti-Aircraft/ground to air, Anti-Robot and Anti-Armor.

Secondary Purpose: Defense and Anti-Missile.

Mega-Damage: Varies with mini-missile type. Any mini-missile can be used, but standard issue is always plasma (1D6x10 M.D.). Fragmentation (5D6 M.D.) may be used for anti-personnel operations.

Range: Usually about a mile (1.6 km).

Rate of Fire: One at a time or a volley of two, three, four, six or twelve.

Payload: 12 total, six on each side of the chest.

3. **Dragon’s Breath Plasma Ejector:** A short stream of flaming plasma can be fired from a housing in the helmet, simulating fire breath.

Primary Purpose: Self-Defense and Close Combat.

Mega-Damage: 5D6 M.D.

Rate of Fire: Dragon’s Breath blast counts as one melee attack.

Range: 100 feet (30.5 m).

Payload: Effectively unlimited.

Bonus: +2 to strike when grappling with an opponent.

4. **Retractable Plasma Swords (2):** A pair of Vibro-Swords are concealed in the forearms of the Sun Chariot and used in close combat when in armor configuration.

Primary Purpose: Close Combat and Self-Defense.

Mega-Damage: 3D6 M.D.

Range: Close Combat weapons only.

Bonus: As per W.P. Sword.

5. **Chariot Configuration:** Ideal for high speed pursuits/chases and quick escapes. Once Chariot "config" is engaged, it generates a fiery plasma field around the Sun Chariot capable of inflicting serious damage to anyone who touches it. Anyone who grabs or leaps on top of a Sun Chariot is burned, suffering 2D6 M.D. initial damage and 2D6 M.D. additional for every melee round (15 seconds) he tries to hold on (which usually isn't more than 2D4 seconds). The burning vapors blind unprotected eyes even of Mega-Damage beings, forcing the individual to close them tightly and temporarily blinding the character the entire time he is holding on to the Sun Chariot and for 1D6 melee rounds after letting go. The penalty for being blinded is -10 on all combat rolls. Those in protective armor will still find their vision obscured because the plasma vapors create a thick, fiery mist that engulfs them. However, no permanent damage is done to the eyes and vision recovers as soon as they let go.

The plasma field does have a few fatal flaws. The first is that the magnetic field that maintains the plasma field around the Sun Chariot interferes with communications systems and electronics (-30% on all skill rolls involving communications and reading sensors, reduce the distance of outgoing transmissions by 70% and incoming messages are filled with static and missing words). Second, the magnetic field does not protect anything the Sun Chariot is carrying or holding, and such things are burnt to a cinder by the plasma field. Third, only the Plasma Cartridge Forearm Weapons can be fired in Chariot configuration, and they are locked in a fixed forward position. To fire missiles, use any of the other weapons, or to engage aerial opponents, the pilot must stop and transform into the "armor" configuration (counts as two attacks/actions for that melee round). The only other mode of attack available in Chariot config is to sideswipe an opponent or slam/ram into his target over and over again, like an angry, flaming ping-pong ball. Every ram/sideswipe does 3D6 M.D. (2D6 points being burn damage from the plasma field) to the opponent and has a 01-88% likelihood of knocking the opponent off his feet and sending him flying 1D4x10 yards/meters (loses initiative and two melee attacks in the process) – 2D6 M.D. greater damage if the Chariot is going faster than 250 mph (400 km) – but the power armor also takes 1D6 M.D. from each ram/sideswipe/crash attack (damage is minimal thanks to the Thermo-Kinetic alloy that makes up the armor).

6. **Hand to Hand Combat:** Rather than use a weapon, the pilot can engage in Mega-Damage hand to hand combat.

Bonuses and Damage from Sun Chariot PA Combat Training:

Restrained Punch: 2D6+5 S.D.C.

Full Strength Punch: 1D4 M.D.

Power Punch: 2D4 M.D.

Kick: 1D6 M.D.

Leap Kick: 2D6 M.D.

Body Flip/Throw: One M.D. plus victim loses one melee attack.

Body Block/Ram in "armor" configuration: 1D6 M.D. and has a 01-45% chance of knocking one's opponent off his feet (if successful, the target loses the initiative and one melee attack/action), but counts as two melee attacks.

Bonuses: +2 to initiative, +1 to strike, +3 to parry, +2 to dodge, +3 to dodge while in chariot mode, +2 to roll with impact, +5 to roll with impact while in chariot mode, +2 to disarm, +1 to pull punch, and +1 attack per melee at levels 1, 4, 8 & 12. Don't forget, heat, fire, explosions and most projectile weapons, including rail gun fire, do half damage.

Robots

NE-DXZ-09 "Hammer" Super Combat Robot

The Hammer Super Combat Robot is the big brother of the Razor Power Armor and has been used for centuries in the Phase World dimension. The Hammer is laid out in a similar fashion to the smaller power armor but has a different body styling and combat capabilities. The Hammer was actually designed first and lacks the speed and mobility of the smaller unit. However, what the Hammer lacks in maneuverability it makes up for in armor and raw firepower. The Hammer is a walking arsenal of mini-missiles and energy weapons. Its entire upper body can also rotate 360 degrees, so the Hammer can spin to face an enemy to the side or behind it without having to move its legs. The legs are thick and strong, able to crush cars underfoot and smash through S.D.C. and light M.D.C. buildings. Its large feet provide excellent balance and stability, making it difficult to trip or knock over the giant robot vehicle. And though not as fast and agile as the Razor and other smaller, newer robots, the Hammer has reasonably good speed, leaping and maneuvering abilities in various types of terrains and environments. Its massive first strike potential should not be underestimated. It is a walking tank, and is called the "Hammer" because it pounds the enemy into submission, and when necessary, into oblivion. It is our contention that a small squad of Hammers could go toe to toe with a company of Glitter Boys or Coalition Skull Smashers and come out the winner. Of course, this is just an example, we're not suggesting anyone should take on the Coalition or the Army of Free Quebec.

Model Type: NE-DXZ-09 Hammer Super Combat Robot.

Class: Strategic Urban Assault Robot.

Crew: Three: One pilot (dedicates all his efforts to the movement of the robot), one gunner (directs both weapon arms and missiles) and one communications officer. Can seat three additional passengers or 600 lbs (270 kg) of cargo.

M.D.C. by Location:

Main Missile Launcher (1, chest, flip top) – 380

Secondary Mini-Missile Shoulder Launchers (2) – 200 each

Multi-Weapon Forearms (2) – 320 each

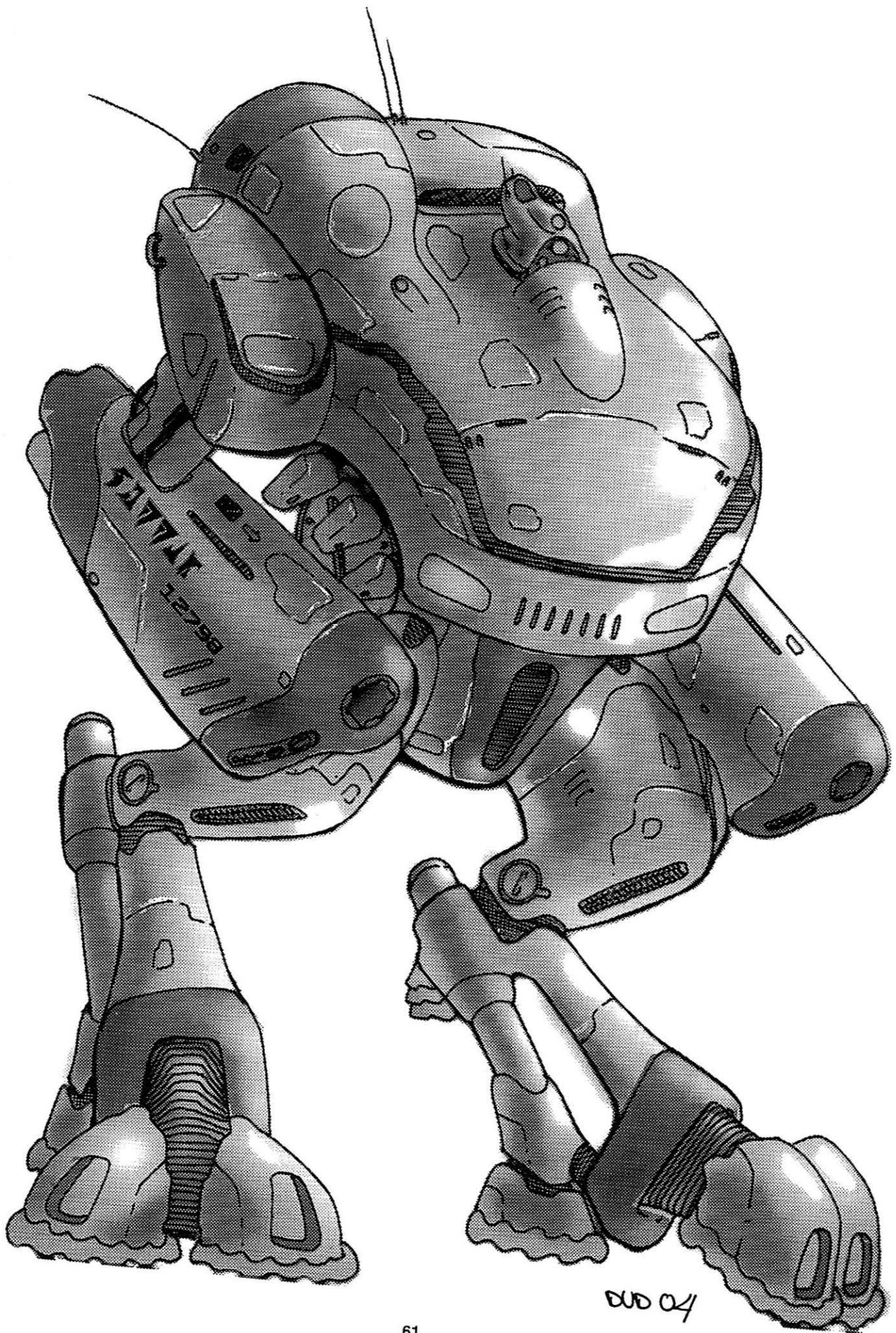

Upper Arms (2) – 220 each
Legs (2) – 320 each
Feet (2) – 200 each
Reinforced Pilot's Compartment – 180
*Sensor Head (top) – 140
**Main Body – 900
***Rear Booster Jets (4) – 80 each

* Destroying the sensor head of the robot eliminates all forms of optical enhancement and sensory systems. The pilot must now rely on his own vision and senses, looking through a small view port in the robot's chest or video feed on monitors. Loses all combat bonuses provided by the robot vehicle. **Note:** The sensor head is a small and difficult target to hit, shielded by the shoulder plating. Thus, it can only be hit when an attacker makes a "called shot" and even then the attacker is -3 to strike.

**Depleting the M.D.C. of the main body shuts the robot down completely, making it useless.

*** Destroying all four of the booster jets will not significantly impair the Hammer's speed; reduce maximum speed to 60 mph (96 km), but it will eliminate the ability to perform thruster assisted leaps and inflicts a penalty of -1 to dodge. Destroying less than all four only reduces thruster assisted leap range by half and it inflicts the penalty of -1 to dodge.

Speed:

Running: 90 mph (144 km) maximum. Note that the act of running does not tire the pilot in the least. Cruising speed is a more cautious 40-50 mph (64 to 80 km). Well suited for most terrains, including rocky and mountainous surfaces, stabilized and provided with a push by the rear booster jets.

Leaping: The powerful robot legs can leap up to 10 feet (3 m) high and 15 feet (4.6 m) across. A jet thruster assisted leap from a stationary position can propel the robot up to 50 feet (15.25 m) high and across. Getting a running start and then a boost from the jet thrusters propels the huge robot up to 80 feet (24.4 m) high and 100 feet (30.5 m) lengthwise.

Underwater: Maximum speed of 40 mph (64 km/34 knots) using the booster jets, or walking along the floor of the sea at a speed of 20 mph (32 km).

Maximum Depth Tolerance: One mile (1.6 km).

Flying: Not possible. The rear rocket system is to provide balance stability and enhanced leaping, not flight.

Statistical Data:

Height: 30 feet (9.1 m) from head to toe.

Width: 16 feet (4.8 m).

Length: 18 feet (5.5 m).

Weight: 24 tons.

Physical Strength: Equal to a Robotic P.S. 50.

Cargo: Large storage area for the crew's personal items, as well as a weapon bin that has room for six rifles and pistols, two heavy weapons, three sets of body armor, basic gear and a four week supply of food and water, plus 300 lbs (135 kg) of additional equipment.

Power System: Nuclear; average energy life is 20 years.

Cost: 65 million credits; the low price resulting from cost reduction and mass production over centuries of time.

Weapon Systems:

1. **IML-2020 Integrated Missile Launcher System** (1, chest): The forward plate of the Hammer's chest flips open like the hood of an automobile to launch either short-range missiles or mini-missiles.

Primary Purpose: Anti-Aircraft/Anti-Robot/Anti-Fortifications.

Secondary Purpose: Assault and Defense.

Mega-Damage: Varies with type of missile. Any short-range missiles can be used, but standard issue is armor piercing (1D6x10 M.D.) or plasma (1D6x10 M.D.). Fragmentation are used in anti-personnel operations. May also fire K-HEX warheads (see *Rifts® G.M. Guide*, page 153, for details on K-Hex, and page 123 for short-range and other missile types).

Mini-missiles are part of the secondary combat system of the IML. Any type of mini-missile can be fired. High Explosive and Fragmentation do 5D6 M.D., Armor Piercing: 1D4x10, Plasma: 1D6x10 M.D.C., or smoke (for strategic cover).

Range: Short-Range Missiles: Usually about three to five miles (4.8 km to 8 km). Mini-Missiles: One mile (1.6 km).

Rate of Fire: One at a time or a volley of two, three, four, six, eight or twelve.

Payload: 12 short-range missiles and 96 mini-missiles.

2. **Shoulder Mini-Missile Launchers (2):** The top, forward plate on the shoulder flips open to fire more mini-missiles.

Primary Purpose: Combat/Anti-Aircraft and Anti-Robot.

Secondary Purpose: Defense.

Mega-Damage: Varies with mini-missile type. Any mini-missile can be used, but standard issue is armor piercing (1D4x10 M.D.) or plasma (1D6x10 M.D.). Fragmentation and high explosive (both doing 5D6 M.D.) are reserved for anti-personnel operations.

Range: Usually about a mile (1.6 km).

Rate of Fire: One at a time or a volley of two, three, four, or six.

Payload: 64 total; 32 per shoulder.

3. **Multi-Weapon Forearms (2):** These huge weapon platforms can rotate at the elbow as well as rotate up and down 360 degrees to strike at enemies up, down and to all sides.

Primary Purpose: Assault.

Secondary Purpose: Defense.

Mega-Damage: The four weapon systems are as follows:

Heavy Plasma Cartridge Cannon: 1D6x10 M.D. per round or a controlled three round burst that does 3D4x10 M.D.

Heavy Laser: Has two settings: 5D6 M.D. or 1D6x10 M.D.

Heavy Particle Beam: 1D6x10+6 M.D. per particle beam blast.

Ion Blaster: 1D4x10 M.D.

Rate of Fire: Each weapon blast and burst counts as one melee attack, as does a missile volley. Only one type of weapon can be fired, per weapon arm, at a time, but the Multi-Weapon Forearms offer an amazing array of combat choices and both arms can be aimed and fired simultaneously at the same target doing simultaneous damage from each arm with full benefit of its combat bonuses when operated by the gunner.

Range: Heavy Plasma Cartridge: 4000 feet (1219 m), Laser: 3000 feet (914 m). P-Beam and Ion Blaster have a range of 1200 feet (366 m).

Payload: Heavy Plasma Cartridge Cannons (2): 1800 rounds (600 bursts), energy weapons, effectively unlimited.

4. **Hand to Hand Combat:** Rather than use a weapon, the pilot can engage in Mega-Damage hand to hand combat.

Damage and Bonuses from Hammer Combat Training: Note that when taking Robot Combat: Elite for the Hammer Robot you also get Power Armor Combat: Elite for the Razor PA, due to their great similarity. The Hammer can use its multi-weapon forearms as bludgeons that hit with the power of a battering ram.

Restrained Punch: 1D6 M.D.

Full Strength Punch: 2D6 M.D.

Power Punch: 1D6x10 M.D.

Kick: 4D6 M.D.

Leap Kick: 1D6x10 M.D.

Stomp: 3D6 M.D., but only usable on targets less than 15 feet (4.6 m) tall.

Body Block/Ram: 6D6 M.D. and has a 01-95% chance of knocking its opponent off his feet and 1D6x10 yards/meters away (victim loses initiative and three melee attacks). Counts as two of the Hammer's melee attacks/actions.

Bonuses: +1 to initiative, +2 to strike, +2 to parry, +1 to dodge, +2 to roll with impact, +3 to pull punch, and +1 melee attack at levels 1, 3, 6, 9, 12, and 15.

NE-R2000 "Reaper" Assault Robot

This is one of our newest designs and comes highly recommended to the fallen nation of Tolkeen and anyone looking to strike the fear of god into their enemies. Occupying Coalition forces, beware.

The Reaper is designed to look like an amalgamation of the old and new style Skelebots, but the Reaper Assault Robot stands over 30 feet (9.1 m) tall and carries an immense energized scythe, able to rend armored robots and vehicles in half. The Reaper robot is a weapon of psychological warfare as much as it is a front-line robot combat vehicle. Though it is making its debut here, on Earth, the Reaper has been fully tested and includes a number of advanced weapons, including our new series of Micro-Missiles, instead of conventional mini-missiles, particle beams that shoot from the eyes, and energy bolts from the giant energy scythe (which helps to preserve the image of the Reaper as the embodiment of Death on Earth).

Although the NE-R2000 Reaper Assault Robot is quite expensive, Naruni Enterprises offers a generous payment plan and even allows the victors to sell captured equipment, lands and mineral rights against any debts with Naruni Enterprises, as well as prisoners sold off as slaves. We offer top credit on any new weapons or vehicle designs to those who prove they can make monthly payments. So as you can see, the cost of the Reaper is really only an issue if you lose the war. Why buy scrap when you can get the best we have to offer?

Model Type: NE-R2000 Reaper Assault Robot.

Class: Tactical Assault and Psychological Warfare Robot.

Crew: Three: One pilot (who dedicates all his efforts to the movement and actions of the robot, including the use of the energy scythe), one gunner (directs all weapons other than the scythe) and one communications officer. Can seat three additional passengers or 600 lbs (270 kg) of cargo.

M.D.C. by Location:

Energy Scythe (1) – 200 (invulnerable when energized)

Arms (2) – 280 each

Hands (2) – 320 each

Legs (2) – 620 each

Feet (2) – 250 each

Reinforced Pilot's Compartment – 250

*Head (packed with sensors and optics) – 500

**Main Body – 2600

* Destroying the sensor head of the robot will eliminate all forms of optical enhancement and sensory systems, forcing the pilot to rely on his own human vision and senses, looking through a small view port in the robot's chest. Furthermore, any bonuses provided by the robot are lost. **Note:** The sensor head is a small and difficult target to hit, shielded by the shoulder plating. It can only be hit when a character makes a called shot and even then the attacker is -3 to strike.

** Depleting the M.D.C. of the main body destroys the robot completely.

Speed:

Running: 130 mph (208 km) maximum. The act of running does not tire out its operator.

Leaping: The powerful robot legs can leap up to 30 feet (9.1 m) high or across. Getting a running start will enable the Reaper to leap up to 100 feet (30.5 m) lengthwise.

Underwater: Can walk along a river or lake bed at 30 mph (48 km), but it sinks like a stone (can not swim).

Maximum Depth Tolerance: One mile (1.6 km).

Flying: Not possible.

Statistical Data:

Height: 32 feet (9.7 m) from head to toe.

Width: 18 feet (5.4 m).

Length: 12 feet (3.6 m), has a fairly thick torso.

Weight: 29 tons.

Physical Strength: Equal to a Robotic P.S. 50.

Cargo: Large storage area for the pilot's personal items, as well as a weapon bin that has room for eight rifles and pistols, two heavy weapons, four sets of body armor, basic gear for the crew, and a four week supply of food and water.

Power System: Nuclear; average energy life is 20 years.

Cost: 115 million credits, additional micro-missiles and are sold separately.

Weapon Systems:

1. **Multiple Micro-Missile Integrated Launcher System (1):** The Reaper has a series of concealed micro-missile launchers built into it, and even with a careful inspection there is only a 01-08% chance of discovering the micro-missile launchers until they fire. All of the micro-missile launchers are integrated into one massive, interconnected micro-missile launching system, able

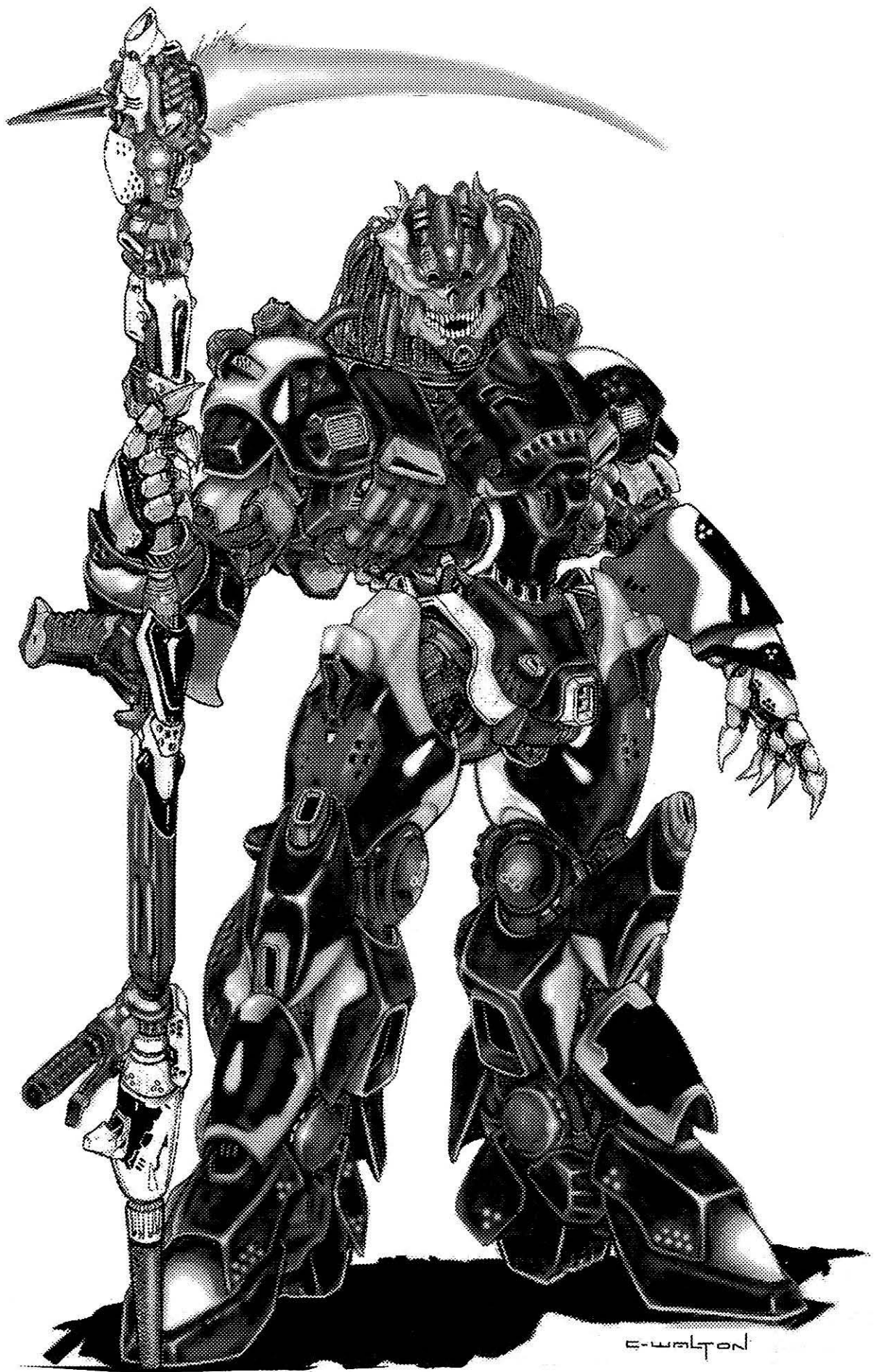

to fire as few as a single micro-missile to as many micro-missiles as desired, up to its entire payload at one time.

Primary Purpose: Anti-Aircraft/Anti-Armor.

Secondary Purpose: Self-Defense and Counter Missile Defense.

Mega-Damage: 6D6 M.D. per armor-piercing micro-missile to a 3 foot (0.9 m) area.

Range: The Reaper exclusively uses the smart AP Micro-Missiles with a 2 mile (3.2 km) range.

Rate of Fire: One at a time or a volley of two, three, four, six, 12, or 24.

Payload: 668 total AP micro-missile launchers, distributed around the suit's body. The distribution of the individual micro-missile launchers is as follows: Head: 8 micro-missile launchers. Shoulders: 160 micro-missile launchers each. Upper Arms: 60 micro-missile launchers each. Lower Arms: 30 micro-missile launchers each. Upper Legs: 80 micro-missile launchers each.

Bonuses: Smart micro-missiles are +4 to strike. If they miss, they will double back and attack again (two attacks per melee round!). Their size makes them very difficult targets to hit (require a called shot to strike and they can dodge at +4). They fly at relatively low speeds (Speed 88, or 60 mph/96 km) to weave around obstacles. If the target is fast-moving or there is a clear path towards it, the missile can attain a flight speed of up to Mach 2 (1440 mph/2304 km). The replacement cost is 8000 per smart AP micro-missile.

2. Particle "Eye" Beams (2): Mounted in the eyes of the Reaper are a set of particle beam weapons. They are fixed forward, so to aim the robot must move its entire head.

Primary Purpose: Assault.

Secondary Purpose: Defense.

Mega-Damage: 1D4x10+6 M.D. per single eye beam, or 2D4x10 if both eye beams are fired simultaneously at the same target.

Rate of Fire: Each single or double blast counts as one of the gunner's attacks per melee round.

Range: 1200 feet (366 m).

Payload: Effectively unlimited.

Bonus: +2 to strike.

3. Energized Combat Scythe (1): A large weapon with a long, double-edged blade on one side and a short pick on the other. The shape of the shaft gives it a sort of scythe-like appearance, just the sort of death symbolism the designers intended. This weapon adds to the Reaper's psychological impact, as well as the real advantages of length of reach and chopping and slashing action.

Weight: 1000 lbs (450 kg).

Size: 40 feet (12.2 m) long.

Primary Purpose: Close Combat and intimidation.

Secondary Purpose: Anti-Armor and Fortifications.

Mega-Damage: Energy Scythe: 5D6 M.D. per slicing or chopping attack. Solid Spike: 3D6 M.D. and Long-Range Energy Bolt: 4D6 M.D. per blast.

Range: Energy Blast: 1200 feet (366 m), otherwise close combat within 40 feet (12.2 m) of the robot.

Rate of Fire: Each combat action counts as one of the pilot's melee attacks.

Payload: Effectively unlimited.

Bonus: +1 to strike, +2 to parry and +3 to disarm with the combat scythe (in addition to other bonuses).

Note: The scythe cannot be thrown.

4. Hand to Hand Combat: Rather than use a weapon, the pilot can engage in Mega-Damage hand to hand combat.

Damage and Bonuses for Reaper Combat Training:

Restrained Punch: 1D6 M.D.

Full Strength Punch: 3D6 M.D.

Power Punch: 6D6 M.D.

Kick: 2D6 M.D.

Leap Kick: 4D6 M.D.

Stomp: 3D6 M.D., but only usable on targets less than 15 feet (4.6 m) tall.

Body Block/Ram: 5D6 M.D. and has a 95% chance of knocking its opponent off his feet (if successful, the target loses the initiative and two melee attacks), but a ram uses up two of the robot's melee attacks.

Bonuses: +2 to initiative, +2 to strike, +2 to parry, +3 to dodge, +2 to roll with impact, +2 to disarm, +2 to pull punch, and +1 attack at levels 1, 4, 8, and 12.

5. Sensor Systems of Note: The Reaper Assault Robot has some of the best sensory equipment available in a robot vehicle. In addition to all the standard robot accessories, the Reaper has the following sensors:

1. Thermo-Imager: A special optical heat sensor that allows the infrared radiation of warm objects to be converted into a visible image. Enables the pilot to see in the dark, in shadows, and through smoke. Range: 5000 feet (1524 m).

2. Infrared and Ultraviolet Optics: This optical system projects a beam of infrared light that is invisible to the normal eye. The infrared beam enables the pilot to see in the dark and to see other infrared beams. The ultraviolet system enables the pilot to see into the ultraviolet spectrum of light and is mostly used to detect the light beams of ultraviolet detection systems. Note: The infrared light beam can be seen by anybody who also has infrared optics, and the beam can be traced back to its source. Smoke impairs the infrared beam, making it impossible to see.

3. Infrared Searchlights: The eyes of the Reaper Assault Robot contain a pair of headlight, that also serve as infrared searchlights. The lights can be used to scan an area at night using the invisible light to avoid detection, or they can illuminate the area in visible light. Only somebody who can also see infrared light will see the infrared beam. Range: 2000 feet (610 m).

4. Enhanced Radar: Can identify and simultaneously track up to 96 different targets. Range: 100 miles (160 km).

5. Gravitic Sonar: In addition to the upgraded radar, the Reaper has an advanced system that uses gravity waves as a form of "sonar." This system can electronically map even the insides of structures (and any occupants). Combined with the enhanced thermo-imager, the sensor system can detect invisible targets, find people hiding inside buildings or vehicles, and even detect traps and hidden troops. The sensor system cannot penetrate force or phase fields, however. Range: 500 feet (152 m).

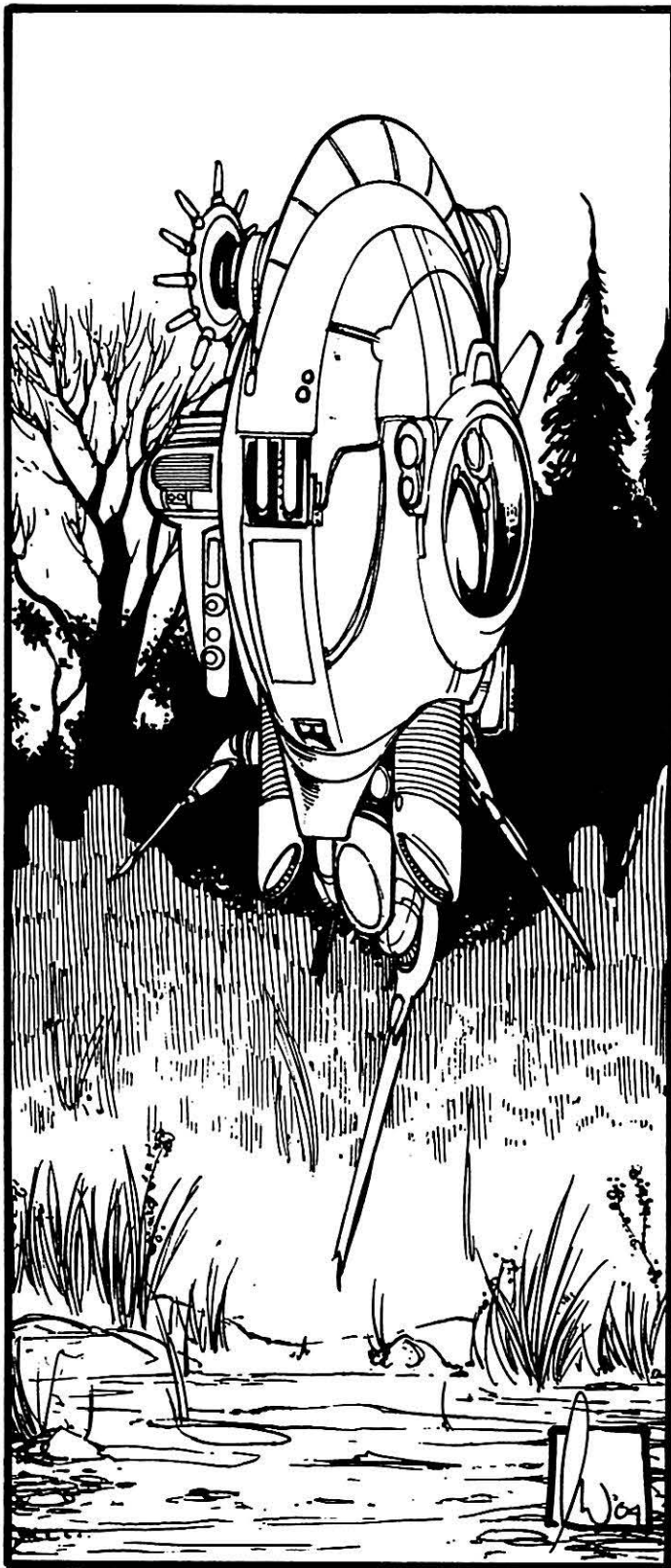

NE-040 Point Defense Drone

By Patrick Nowak

The NE-040 Point Defense Drone is not so much a combat pod as it is a remote sensor module and detection device. It differs from Naruni Enterprises' previous combat pods in that the point defense drone is much smaller, measures just two feet (0.6 m) in diameter, and is lightly armed. Instead of heavy combat, this

robot drone is designed to be used as a sentry, advance scout and early detection module. Typically, the NE-040 is employed in the role of a sentry, monitoring a specific area or location using its sensors to search for any signs of infiltration or intruders. If an intrusion is detected, the drone transmits all relevant data to its operator, to an OMAV command drone or to a control center. Additionally, the NE-040 can be used to replace a humanoid "point man" on combat patrols and reconnaissance. The drone is sent in advance of troops and vehicles to scout for signs of the enemy, or to search abandoned positions, fortifications and buildings. Again, all data is transmitted to the drone's commanding unit whether that is a human operator with a remote or an OMAV pod.

What makes the NE-040 so effective as a scout and sentry is the inclusion of stealth technology in its design. The pod features many of the same stealth systems found in many other Naruni Enterprises vehicles and armor, including radar absorbing materials, IR suppressors and sound suppressors to mask the sounds of its engines. The overall effect is that the drone is difficult to detect using modern sensory equipment, incurring a penalty of -50% to Read Sensory Equipment checks to detect the pod. The NE-040 is highly effective as a scout vehicle, allowing normal troops to avoid heavy casualties by early detection of threats before they are stumbled upon. It is becoming very popular with mercenary units, assassins, thieves and spies in areas throughout the Americas.

Model Type: NE-040 Point Defense Drone.

Class: Drone Combat Scout & Sentry Pod.

Crew: None; unmanned drone.

Speed: Hover in a stationary position or fly at speeds up to 50 mph (80 km). Minimum hover height is one foot (0.3 m) with a maximum height of 150 feet (45.7 m).

Size: Two feet (0.6 m) in diameter; spherical.

Weight: 42 lbs (19 kg).

Power System: NE-EB battery with 96 hours of life per charge.

M.D.C. by Location:

Optical Sensor Eye (1) – 15

Sensor and Transmitter Crown (side, top) – 15

Main Sensor Cluster (bottom) – 20

Small Defense Laser (1) – 10

Main Hover Jets (3) – 10 each

Directional Jets (9) – 3 each

Main Body – 80

Robot Defense System: Combat programs enable it to recognize, locate and identify targets 89%, hide and Prowl at 89%, Land Navigation 89%, Detect Ambush 60%, Detect Concealment 60%, and can recognize 1000 different targets.

Sensors & Optics: Five video cameras to capture and transmit whatever it sees, infrared, ultraviolet, passive night-sight, thermal imaging and laser targeting (3000 foot/914 m range). Motion detector and radar (can track 100 targets, three mile/4.8 km range). Full radio transmission and reception, plus radio scrambler (500 mile/800 km range).

Combat Bonuses: +3 on initiative, +4 to strike, +8 to dodge, three attacks per melee.

Market Cost: 500,000 credits, complete with HUD visor and re-

mote control module for the human monitoring the drone's progress.

Weapon System:

1. **Light Laser:** A basic laser for defense and cutting away S.D.C. and light M.D.C. debris and underbrush.

Mega-Damage: Small Light Laser: 2D6 M.D. per blast.

Rate of Fire: The drone has four attacks/actions per melee round.

Range: 2000 feet (610 m).

Payload: 200 laser blasts without significantly reducing the battery's life.

tem and capable of hovering in a stationary position. Minimum hover height is 20 feet (6.1 m) with a maximum altitude of 20,000 feet (6,096 m).

Flying Range: The nuclear power supply gives the NE-A420 years of life, but the jets need cooling after 48 hours of continuous use at cruising speed, or 24 hours at maximum speed.

Statistical Data:

Height: 18 feet (5.5 m).

Width: 10 feet (3 m) with wings up; 30 feet (9.1 m) with wings spread.

Length: 12 feet (3.6 m).

Weight: 24 tons.

NE-A420 Ground Attack Drone Fighter

By Patrick Nowak

NE-A420 Ground Attack Drones are aerial robot fighter pods designed not to combat other aircraft, but to engage ground targets in a role similar to attack helicopters. In its general appearance the drone is more similar to the standard OMAV pod, with an ovoid, egg-shaped fuselage from which protrudes stubby wings for greater stability and on which to mount additional ordnance. The NE-A420 has a top speed of 600 mph (960 km) which is fast enough to catch most ground vehicles and flying power armor. It is extremely capable at engaging ground targets including military fortifications, armored vehicles and infantry formations.

The NE-A420 Ground Attack Drone is piloted remotely by a humanoid operator using a remote or virtual reality system.

Model Type: NE-A420 Drone Fighter.

Class: Ground Attack Combat Fighter Drone.

Crew: None.

M.D.C. by Location:

Main Jet Thrusters (3) – 90 each

Contra-Gravity Jets (2; underbelly) – 240 each

* Sensor Array (1, top radar dish) – 45

* Communications Cluster (1; bottom) – 100

* Pulse Laser Cannon – 70

* Medium Missile Pylons (8; wings) – 20 each

Mini-Missile Launcher Module (1, front) – 150

Wings (2) – 100 each

** Main Body – 500

* Targets marked with a single asterisk are small and difficult targets to hit, requiring a "called shot" at -3 to strike.

** Depleting the M.D.C. of the main body destroys the drone. If only the communications cluster is destroyed it is no longer possible to control the drone remotely and it will continue to act on its last command and basic protocols (i.e., search and destroy the enemy) until it is disabled or destroyed.

Speed: Maximum speed of 600 mph (966 km). Cruising speed is considered to be from 50-200 mph (80 to 320 km). VTOL sys-

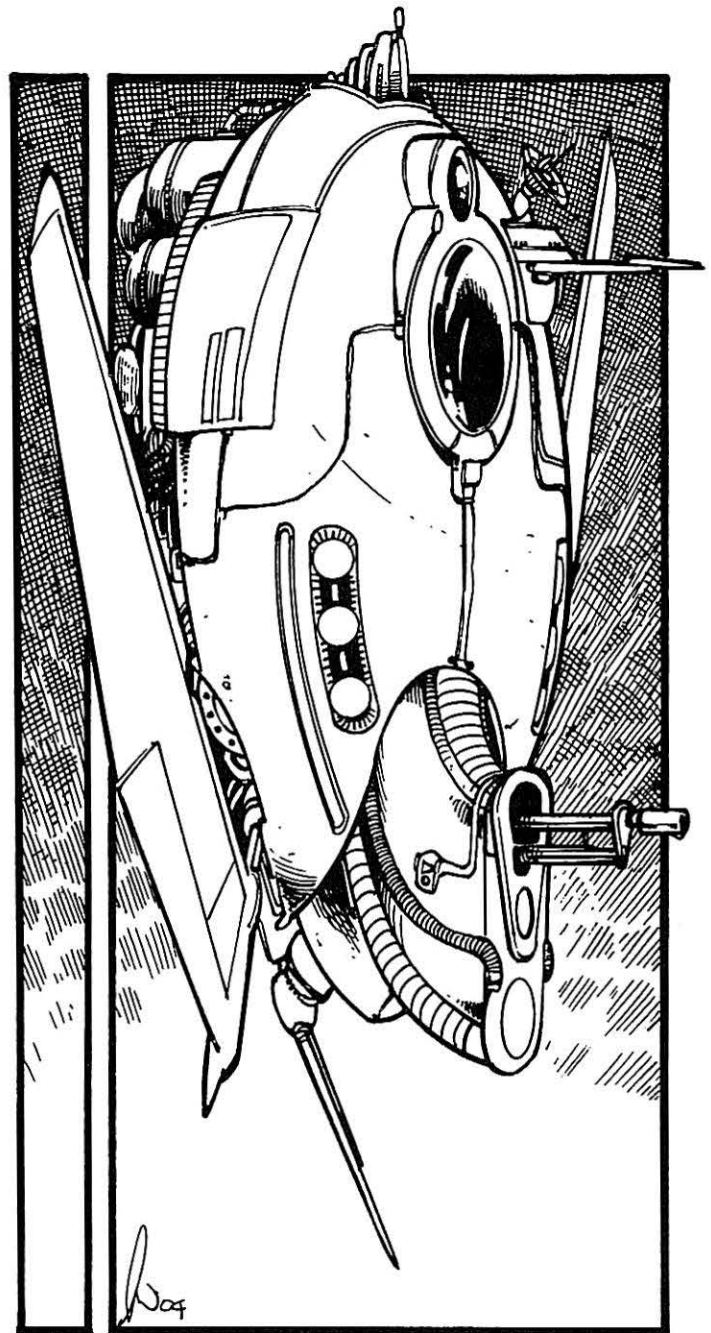

Cargo: None.

Power System: Nuclear; average energy life is 8 years.

Market Cost: 24 million credits for a drone with only a remote control system. 28 million for a virtual reality system with remote control back-up system. May cost 10% to 25% more depending on availability (and Naruni discretion). Vehicle is purchased with one full complement of missiles and ammo. Additional reloads sold separately.

Weapon Systems:

1. **Pulse Laser Cannon (1):** Mounted at the nose of the drone is a high-intensity pulse laser cannon. The cannon is fixed in a forward-facing position, and cannot be rotated.

Primary Purpose: Strafing and assault on ground vehicles, robots, troops and fortifications.

Secondary Purpose: Defense.

Mega-Damage: 1D4x10 M.D. per single blast, or 2D6x10 M.D. for a simultaneous three shot pulse.

Rate of Fire: Each blast or burst counts as one melee attack.

Effective Range: 4000 feet (1219 m).

Payload: Effectively unlimited.

2. **Wing Mounted Medium-Range Missiles (8):** Four medium-range missiles are mounted on pylon hardpoints under each stubby wing of the combat drone. These missiles are used mainly to engage armored ground vehicles such as main battle tanks, and bunkers.

Primary Purpose: Anti-Armor and Anti-Fortifications.

Secondary Purpose: Assault.

Mega-Damage: Varies with missile type. Any medium-range missile can be used, but Naruni Enterprises recommends the K-HEX high explosive heavy (3D4x10 M.D.), K-HEX fragmentation (2D6x10 M.D.) and (2D6x10 M.D.). Additional reloads sold separately.

Rate of Fire: One at a time or in volleys of two, four or six. Each volley counts as one melee attack/action.

Range: 40 miles (64 km).

Payload: 8 missiles total; four under each wing.

3. **Internal Mini-Missile Launcher Module:** Located in the mid-section of the drone is a mini-missile bomb bay that contains a helical drum magazine loaded with 96 mini-missiles! These missiles are rapidly fired from six launch tubes (three on each side above the nose) in volleys of 4-12 which can be used to carpet bomb large areas, bunkers, or concentrations of vehicles or armored troops. For quick reloading, the helical module is removable, and can be replaced with a pre-loaded magazine in under five minutes to allow for rapid turn-around between sorties. Actually reloading the magazine is a much slower process that requires 60 minutes.

If the missile bay is severely damaged in combat, or if the drone is about to crash, the entire magazine can be jettisoned to prevent it from exploding and further damaging the airframe. Should the missile module detonate, it inflicts 4D6x10 M.D. to a 40 foot (12.2 m) radius, and does double damage to the drone if it is not jettisoned before exploding.

Primary Purpose: Air to Ground Assault. Anti-Vehicle and Anti-Personnel.

Secondary Purpose: Self-Defense/Counter Missile Attacks and Anti-Aircraft.

Missile Type: Any mini-missile can be used, but Naruni Enterprises recommends the K-HEX fragmentation (1D4x10 M.D.), K-HEX high explosive (1D4x10 M.D.) or plasma (1D6x10 M.D.).

Mega-Damage: Varies by the missile type.

Rate of Fire: One at a time or in volleys of 2, 4, 6, or 12. Each volley counts as one melee attack.

Range: One mile (1.6 km).

Payload: 96 missiles total (8 full volleys).

4. **Robot Combat Programming:** Advanced combat programming enables the drone to recognize, locate and identify targets 89%, hide and Prowl at 48%, Land Navigation 89%, Detect Ambush 56%, Detect Concealment 56%, can recognize 3000 different targets, and jet fighter combat "basic" training.

Bonuses: +2 on initiative, +6 to strike, +7 to dodge, +1 to dog-fighting rolls, and has five attacks per melee round.

5. **Sensors of Note:** Full range optics equal to a multi-optics helmet, including thermo-imager, infrared, ultraviolet, passive night-sight, telescopic, and laser targeting (5000 foot/1524 m range). Motion detector, heat sensor, radiation sensor, radar detector, advanced radar (can track 120 different targets, 50 mile/80 km range), full radio transmission and reception, radio and scrambler.

NE-A400 Interceptor Drone

By Patrick Nowak

The NE-A400 Interceptor Drone marks a departure from standard Naruni Enterprises combat "pod" designs and is an actual aircraft. The drone functions as an unmanned interceptor rather than as an infantry combat drone. As a result, the drone is built along the lines of a typical fighter aircraft rather than the standard ovoid pod design, with a roughly dagger-shaped fuselage, triangular wings and stabilizer fins. The Interceptor Drone is fast (top speed of Mach 1.5/1005 mph/1608 km), agile and carries a large weapons payload. The sophisticated robot combat programming allows the vehicle to pursue, intercept, divide and engage in dog-fights on an impressive level. While it may lack human instinct, it is a capable robot aircraft that holds its own in aerial combat with manned and unmanned opponents. The real beauty of the NE-A400 Interceptor is that there is no need to risk the life of a pilot, and the drone has none of the usual weaknesses of a humanoid pilot – it doesn't require rest or sleep, it doesn't get bored or distracted, it is never afraid or confused, and it follows orders/programming to the letter.

NE-A400 Interceptors are designed to operate independently as a drone following a programmed set of objectives, but like other Naruni Enterprises combat drones, it may also be flown and controlled by a humanoid pilot on the ground via a remote or virtual reality system. When the NE-A400 flies independent of a pilot, the drone is programmed to patrol a specific area of airspace, or it can be linked to a specific vehicle or warship around which it continually flies combat air patrol (CAP). A number of the wealthier kingdoms and mercenary companies have already purchased the NE-A400 to fill the gap in their air combat capabilities and to keep their airspace safe from aerial surveillance and power armor patrols from enemy empires who may be

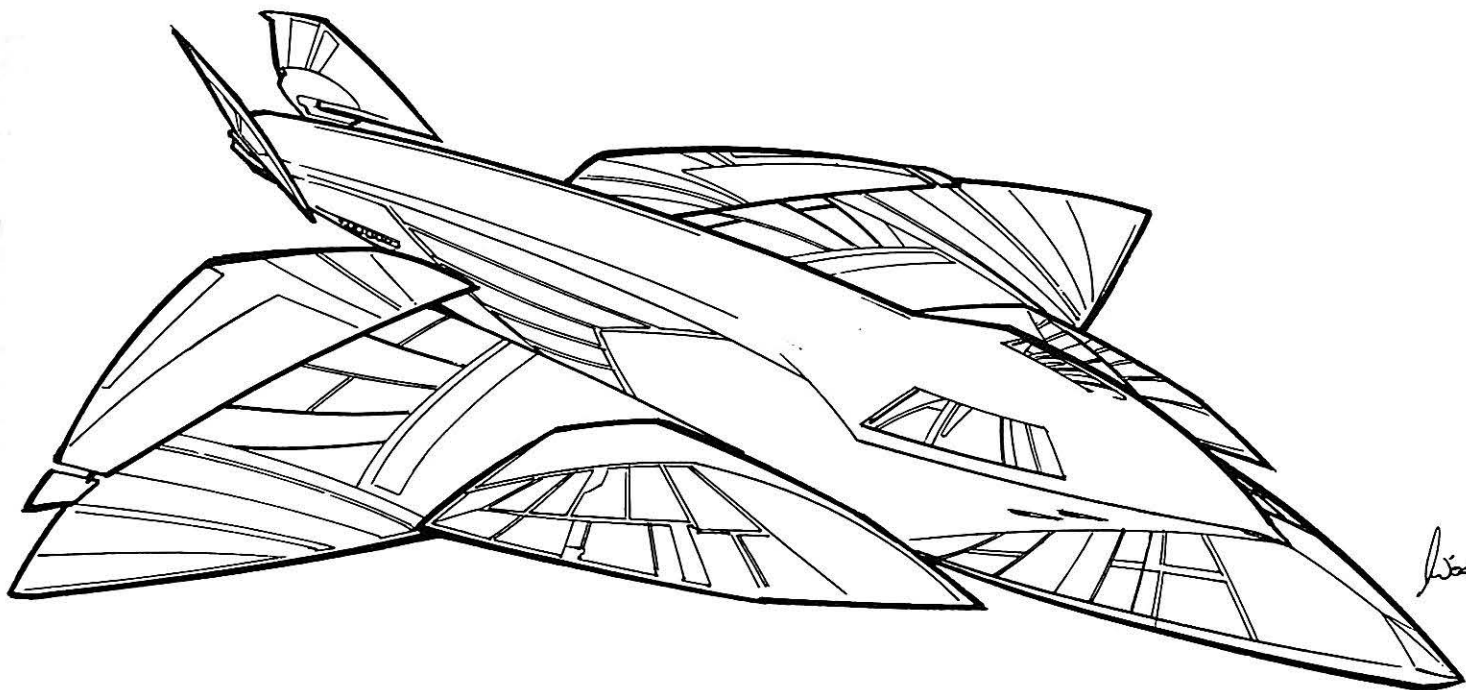

targeting them for invasion. For many of these clients the Interceptor Drones are more cost-effective than having to train or pay full-time pilots and the vehicle itself costs about the same as a modern jet fighter like the Grey Falcon.

Note: Remote or virtual reality piloting of the NE-A400 Interceptor Drone requires training and the Combat Pod Piloting skill found on page 30 of *Rifts® Mercenaries*, or page 68 of the *Rifts® G.M. Guide*.

Model Type: NE-A400 Interceptor Drone.

Class: Air Interceptor Combat Fighter Drone.

Crew: None.

M.D.C. by Location:

- Main Jet Thrusters (4) – 110 each
- Contra-Gravity Jets (2; underbelly) – 200 each
- *Sensor Array (1, concealed in underbelly) – 50
- *Communications Cluster (1, concealed in nose) – 50
- *Pulse Laser Cannon – 70
- *Medium Missile Pylons (8) – 25 each
- Short-Range Missile Launchers (2) – 90 each
- Pilot's Compartment – 150
- Wings (2) – 250 each
- *Tail Fins (2) – 50 each
- **Main Body – 480

* Targets marked with a single asterisk are small and difficult targets to hit, requiring a "called shot" at -3 to strike.

** Destroying the main body causes the vehicle to crash-land. If the communications cluster is destroyed it is no longer possible to control the drone remotely.

Speed: Maximum speed of Mach 1.5 (1005 mph/1608 km). Cruising speed is considered from 300-600 mph (480 to 960 km). VTOL system, capable of hovering in a stationary position.

Minimum hover height is 100 feet (30.5 m) with a maximum altitude of 40,000 feet (12,192 m).

Flying Range: The nuclear power supply gives the NE-A400 years of life, but the jets need cooling after 48 hours of continuous use at cruising speed, or ten hours at maximum speed.

Statistical Data:

Height: 12 feet (3.7 m).

Width: 48 feet (14.6 m).

Length: 42 feet (12.8 m).

Weight: 28 tons.

Cargo: None.

Power System: Nuclear; average energy life is 8 years.

Market Cost: 40 million credits for an Interceptor Drone with only a remote control system. 45 million for a virtual reality system with remote control back-up system. May cost 10% to 25% more depending on availability (and Naruni discretion).

Weapon Systems:

1. **Pulse Laser Cannon:** Concealed in the nose of the aircraft is a high-intensity pulse laser cannon. The cannon is fixed in a forward-facing position, and cannot be rotated.

Primary Purpose: Anti-Aircraft and Dog-Fighting.

Secondary Purpose: Self-Defense.

Mega-Damage: 6D6 M.D. per single blast, or 2D4x10 M.D. for a three shot pulse.

Rate of Fire: Each blast counts as one of the drone's melee attacks.

Range: 4000 feet (1219 m).

Payload: Effectively unlimited.

2. **Pylon Mounted Medium-Range Missiles (8):** Four medium-range missiles are mounted on pylon hardpoints under each wing of the drone. These missiles are used to engage flying targets at long range.

Primary Purpose: Anti-Aircraft.

Secondary Purpose: Air to ground attacks and Anti-Fortifications.

Missile Type: Any medium-range missile can be used, but Naruni Enterprises recommends the K-HEX high explosive heavy (3D4x10 M.D.) or plasma (2D6x10 M.D.).

Mega-Damage: Varies with the missile type.

Rate of Fire: One at a time or in volleys of two or four. Each volley counts as one melee attack.

Range: 40 miles (64 km).

Payload: 8 missiles total; four under each wing.

3. Short-Range Missile Launchers (2): A pair of multiple shot short-range missile launchers are built into the sides of the fuselage. These six tube launchers are located above the wings and are fed from an internal drum magazine which reloads the tubes every five seconds (allowing for three full volleys per melee).

Primary Purpose: Anti-Aircraft and Assault.

Secondary Purpose: Self-Defense.

Missile Type: Any short-range missile can be used, but Naruni Enterprises recommends K-HEX fragmentation (1D6x10 M.D.), K-HEX high explosive (2D4x10 M.D.) or plasma (1D6x10 M.D.).

Mega-Damage: Varies with the missile type.

Rate of Fire: One at a time or in volleys of 2, 3, 4, or 6. Each volley counts as one melee attack.

Range: Three miles (4.8 km).

Payload: 24 short-range missiles total. It is a relatively complicated procedure to reload the internal drum which requires a trained technician and takes about 10 minutes.

4. Robot Combat Programming: Advanced combat programming enables the drone to recognize, locate and identify targets 89%, hide and Prowl at 30%, Land Navigation 89%, Detect Ambush 48%, Detect Concealment 48%, can recognize 2500 different airborne targets, and jet fighter combat "basic" training.

Bonuses: +3 on initiative, +6 to strike, +9 to dodge, +1 to dog-fighting rolls, and has six attacks per melee round.

5. Sensors of Note: Full range optics equal to a multi-optics helmet, including thermo-imager, infrared, ultraviolet, passive night-sight, telescopic, and laser targeting (5000 foot/1524 m range). Motion detector, heat sensor, radiation sensor, radar detector, advanced radar (can track 112 different targets, 50 mile/80 km range), full radio transmission and reception, and radio scrambler.

Naruni Vehicles

New Hovercycles & Ground Vehicles

NE-RB-660 "Spitfire" Contra-Gravity Racing Bike

On Phase World and throughout the Three Galaxies, grav-bike racing is a huge sport. Competitors spend millions or even billions of credits building and modifying their grav-bikes for professional racing. The prize money from major competitions is fabulous and winning a single race can make an individual independently wealthy. Of course, the trick is spending enough to build a bike that can compete and finding a pilot who can break out of the pack and milk his bike for everything it has to cross the finish line first.

Fans of the sport are often avid riders themselves, and many compete in the minor racing circuits just for fun. It's for these intense racing fans that Naruni Enterprises has produced a variety of Contra-Gravity Racing Bikes. We know grav-bike races don't exist on Earth, but since humans, D-Bees, City Rats, mercenaries and people from every walk of life love hovercycles so much, we thought you might enjoy trying out our latest grav-bike model, the "Spitfire."

While not on par with the pros in the racing circuit, the Spitfire is a thrill ride unlike any you've experienced. Not for the faint of heart, the Spitfire will challenge and delight even the most seasoned of you racers and daredevils. It uses Naruni Enterprises' patented Contra-Gravity Generator to defy gravity and fly like lightning. The Contra-Gravity Generator provides most of the lift and speed, but we've added a pair of jet engines for added kick and the roar of thunder to go with the lightning. Directional thrusters in the front, sides and rear help provide stability at great speeds. The Spitfire is also VTOL (Vertical Take-Off and Landing) capable, just another feature of the Contra-Gravity system of flight unknown to Earth, until now. Retractable landing gear keeps the racer's form sleek when in flight.

For you speed-junkies looking for something new and different, a means to travel at dizzying speeds, or a way to make a fast getaway or mount a surprise attack and vanish seconds later, look no further. The Spitfire is your dream come to life.

Model Type: NE-RB-660 Spitfire Contra-Gravity Racing Bike.

Class: Civilian Contra-Gravity Racing Rocket Cycle.

Crew: One.

M.D.C. by Location:

Undercarriage & Landing Gear – 120

* Front Windshield – 50

* Headlights (2; front) – 8 each

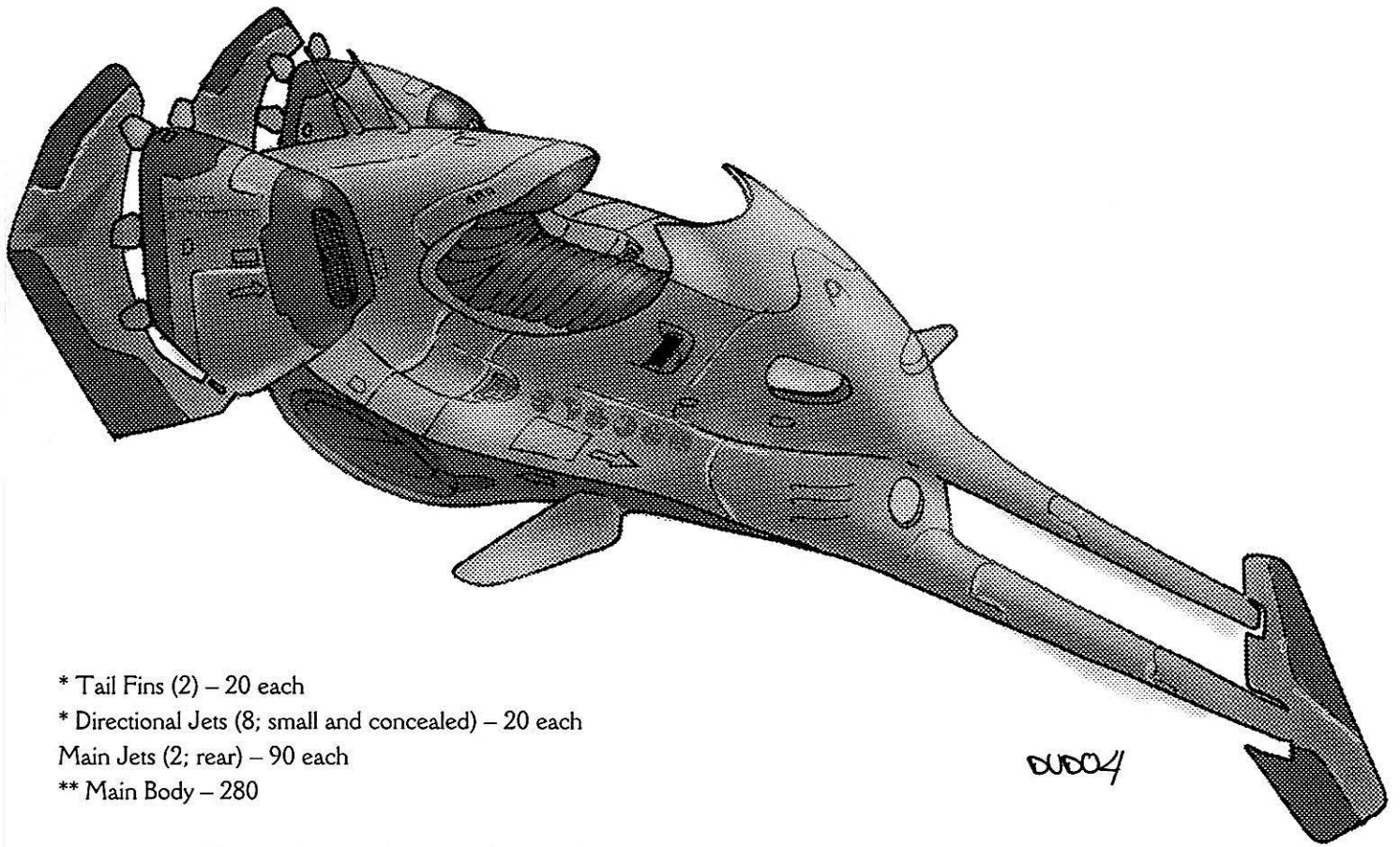

- * Tail Fins (2) – 20 each
- * Directional Jets (8; small and concealed) – 20 each
- Main Jets (2; rear) – 90 each
- ** Main Body – 280

* Items marked by a single asterisk are small and/or difficult to strike. A character must make a “called shot,” but even then the attacker is -4 to strike.

Destroying three or more directional jets inflicts a piloting penalty of -10%. Destroying one of the rear jets reduces speed by 30% and inflicts a piloting penalty of -20%, double the penalties if both are destroyed. Destroying the undercarriage destroys directional jets and the landing gear (the bike lands on its scarred belly and rolls onto one side, but can still land without further damage due to the VTOL capability of the Contra-Gravity generator – reduce speed by 20% and inflict a piloting penalty of -20% due to air drag and imbalance).

** Depleting the M.D.C. of the main body completely destroys the vehicle.

Speed:

Ground Speed: The Spitfire cannot drive on land, it must ride the air at least three feet (0.9 m) above the ground. It is a one-man Vertical Take-Off & Landing (VTOL) “aircraft” designed for flying in an atmosphere and outer space, so it can hover stationary, soar through the clouds and enter the void of space. **WARNING:** Space flight and even high-altitude flying in Earth’s stratosphere is a death wish as it is common knowledge that ancient, but still active orbital combat satellites are still in place and destroy all space vehicles leaving the planet. The Coalition States and Triax have discovered this the hard way. Don’t press your luck or choose to believe this is a myth.

Flying: Contra-Gravity Only: 500 mph (800 km), but cruising speed is considered to range between 80 to 150 mph (128 to 240 km). Kicking in the jet engines rockets the Spitfire up to Mach One (670 mph/1072 km) when in an atmosphere, but this speed can only be maintained for two hours before the Spitfire

must slow down to avoid overheating. The Spitfire can reach speeds of up to Mach 16 (10,720 mph/17,152 km) in outer space for up to 12 hours before needing to rest the jet engines, and can go at Mach 4 (2680 mph/4288 km) without the jet propulsion.

Maximum Altitude: Unlimited. The Contra-Gravity system allows the rocket cycle to escape a planet’s atmosphere and fly out of orbit.

Underwater: Maximum speed of 110 mph (176 km) using the Contra-Gravity System.

Water Speed: The Spitfire can skim across the surface of water at a speed of 200 mph (320 km).

Maximum Depth Tolerance: 300 feet (91.5 m).

Maximum Range: The nuclear power supply gives the vehicle decades of life, and the Spitfire can be used continuously for 12 hours without fear of overheating, but after 48 hours the Spitfire will shut down, due to heat build-up.

Pilot Note: The pilot needs to be wearing full environmental body armor to fly at speeds greater than 200 mph (320 km), otherwise flying debris and the elements will take their toll on his body. Likewise, the driver cannot go into thin layers of the atmosphere, outer space or underwater unless he is clad in environmental armor for obvious reasons (like no breathable air).

Statistical Data:

Height: 3 feet (0.9 m), 4 feet (1.2 m) with landing gear in place.

Width: 4 feet (1.2 m) at its widest point in the back where the fins and jet engines are located. Not even six inches (0.15 m) at its narrowest point at the nose.

Length: 13.3 feet (4 m).

Weight: 1400 pounds (630 kg).

Cargo: Minimal storage space; about 100 lbs (45 kg) of gear can be strapped to the back of the vehicle; no storage compartment. Gear not securely strapped down will be lost when the Spitfire attains high speeds.

Power System: Nuclear; average energy life is 15 years.

Cost: 8.6 million credits; the Contra-Gravity system is expensive and not for everybody.

Weapon Systems:

1. **None:** But many people have been known to mount a light energy weapon to the underbelly and/or nose. As many as eight mini-missiles can be attached to the nose beams, but they require individual launch mounts and even as few as two missiles interferes with the aerodynamics enough to reduce maximum speed by 10%; 6-8 reduces speed by 25%. Projectile weapons such as rail guns and plasma cartridge weapons, and the required ammo drum, reduce the speed of the Spitfire by 30% and are not recommended. Optional weapon systems and mountings sold separately.

2. **Combat Bonuses for the Elite:** Phaeton Juicers, Psi-Techs, elite RPA pilots, RPA "Fly Boys" and similar O.C.C.s get a special bonus of +3 on initiative, +3 to auto-dodge (they are that quick) and get two additional actions/attacks per melee round when piloting this vehicle.



NE-HC-120 "Shadow" Combat Hovercycle

The extreme popularity of hovercycles in North America has led Naruni Enterprises to market several models on Earth, including the Shadow. This cycle is sleek, black with blue, gold or crimson trim, highly maneuverable and designed for stealth. It is faster than many Earth models yet makes only one tenth the engine noise as a result of special filters and mufflers. To aid the pilot in high speed flying, when quiet is not an issue, the vehicle is equipped with twin jet engines that send it rocketing through the sky. A very sophisticated anti-collision radar system provides rele-

vant course data to the pilot via a Heads Up Display (HUD) visor that fits over most helmets or, in the alternative, on the windshield (though the windshield is an optional feature that many purchasers do without). The Shadow can stop or turn on a dime, even when flying at speeds of up to 300 mph (480 km).

There is more to being a stealth vehicle than silent running, and the Shadow incorporates various technologies to reduce the cycle's heat and radar signatures. This makes it very difficult to detect under normal conditions, and attempts to locate the hovercycle using radar and heat sensors suffer a skill penalty of -50% to accurately Read Sensory Equipment and make a clear identification of the Shadow or its exact location strictly using instrument readings. What's more, the hovercycle's engines run "quiet" (one tenth the engine noise of conventional engines) at speeds under 100 mph (160 km) and have a "Whisper Quiet" mode at speeds of 40 mph (64 km) or less. "Whisper Quiet" enables the pilot to drive the hovercycle with the barely audible hiss of the hover and directional jets equal to his Prowl skill, or at a base skill of 33% if the pilot lacks that skill.

Another unique feature of the Shadow hovercycle is its remote piloting capability. The vehicle has a sophisticated onboard computer that can fly the vehicle independent of a pilot, responding to a hailing frequency ("come and get me" signal) or a preprogrammed flight pattern, complete with rendezvous points, the length of the landing or hover time, and the next destination if the rendezvous is not met. This is typically used to provide the pilot with a ride at a specified time when he goes off on foot and to make a quick getaway. The combat programming is a basic and simplified version of what's deployed in Naruni Enterprises' Combat Drones. The Shadow is linked to its owner via a combination remote and homing module that is about the size of a cigarette lighter. Voice commands are used to direct the hovercycle to a specific location ("Advance 300 meters, turn left on Madison and stop at the security fence.") or the pilot's own current position by following the hailing beacon.

All of these systems make the Shadow immensely popular among espionage agents, spies, thieves, smugglers, raiders, assassins, special forces, mercenaries and adventurers with special needs for a smart, quiet bike. Ideal for urban operations and visiting hostile environments where you would rather not be seen. Want to visit the 'Burbs but need to avoid Coalition patrols, bounty hunters or a rival gang? Then the Shadow is probably your best bet. This vehicle enjoys widespread use throughout the Three Galaxies for similar operations and is ranked number one by three out of four military intelligence operatives.

Model Type: NE-HC-120 "Shadow"

Class: Stealth Combat Hovercycle.

Crew: One rider; no space for a passenger.

M.D.C. by Location:

- * Large Hover Jet (2; rear) – 90 each
- * Small Hover Jets (6; undercarriage) – 25 each
- * Directional Hover Jets (6; tiny and concealed) – 5 each
- * Side Stabilizing Wings (2; small) – 15 each
- * Tail Fin (1; large) – 50
- * Forward Headlight (1) – 10
- * Forward Particle Beam Turret (1) – 70
- Windshield (1; optional) – 20
- Main Body – 210

* A single asterisk indicates small and/or difficult targets to hit and requires the attacker to make a "called shot," but even then he is -4 to strike. The driver, hunched down, low to the body of the hovercycle, is equally difficult to hit and enjoys the -4 penalty to be shot.

** Depleting the M.D.C. of the main body completely destroys the vehicle.

Speed:

Flying: 300 mph (480 km), but cruising speed is considered to range from 40 to 100 mph (64 to 160 km). VTOL capable, it can hover stationary; retractable landing gear. Maximum altitude is limited to about 10,000 feet (3050 m), and the cycle can handle drops of up to 4000 feet (1219 m).

Flying Range: The nuclear power supply provides the vehicle with decades of life. The Shadow can be flown continuously, and at top speed, for 36 hours without fear of overheating.

Statistical Data:

Height: 4 feet, 6 inches (1.4 m).

Width: 3 feet (0.9 m).

Length: 7 feet (2.1 m).

Weight: 620 lbs (279 kg).

Cargo: None.

Power System: Nuclear, average energy life is 20 years.

Market Cost: 3.6 million credits. The nuclear power supply and built-in heavy weapons add to the cost, but are worth every credit.

Weapon Systems:

1. Light Particle Beam Turret (1): Built into the nose of the vehicle is a small particle beam turret. It rotates 300 degrees and has a 40 degree arc of fire up and down. When in stealth mode, the gun arm folds back and up into a housing where the weapon is concealed and enjoys the benefits of the radar and heat masking shielding of the rest of the vehicle.

Primary Purpose: Defense.

Secondary Purpose: Assault/Anti-Aircraft.

Mega-Damage: 6D6+6 M.D.

Rate of Fire: Each blast counts as one of the pilot's melee attacks/actions.

Range: 1200 feet (366 m).

Payload: Effectively unlimited.

2. Light S.D.C. Machine-Gun (2): A pair of machine-guns are tucked under the nose of the hovercycle just behind the P-Beam turret. They are locked in a fixed forward position and intended for anti-personnel operations against unarmored opponents.

Primary Purpose: Assault and Anti-Personnel.

Secondary Purpose: Defense and Dog-Fights.

Damage: A single shot from one machine-gun inflicts 5D6 S.D.C., two simultaneous shots do 1D6x10 S.D.C., a short burst of 10 rounds does 5D6x10 S.D.C. or one M.D. point and a heavy burst of 20 rounds does 1D6x100 S.D.C. or 1D6 M.D.

Rate of Fire: A single shot or burst counts as one melee attack.

Range: 2000 feet (610 m).

Payload: 1200 round drum provides 60 heavy bursts or 120 short ones. Reloading a drum takes about 5 minutes for those not trained, but just one minute by a trained soldier.

3. Mini-Missile Pods (2): At the buyer's option, a pair of mini-missile pods can be attached to the sides of the fuselage to provide additional firepower. The problem is that the missile pods dramatically increase the overall radar signature of the cycle (reduce the Read Sensory Equipment skill penalty of the enemy to only -20% if the cycle is outfitted with mini-missile pods).

Primary Purpose: Anti-Aircraft.

Secondary Purpose: Anti-Armor.

Missile Type: Any mini-missile can be used, but we highly recommend the K-HEX high explosive (1D4x10 M.D.), armor piercing (1D4x10 M.D.) or plasma (1D6x10 M.D.).

Mega-Damage: Varies with the missile type.

Rate of Fire: One at a time or in volleys of 2, 4, 5 and 10.

Range: One mile (1.6 km).

Payload: 10 mini-missiles total; five per each launcher.

4. Sensors & Features of Note: 1. Stealth System: The Shadow employs the identical stealth technology as the NE-SA40 Stealth Exoskeleton. It is composed of radar absorbing materials, has a minimized radar signature about the size of a crow, and IR suppressors to defeat thermal-imaging. These features combine to make the hovercycle (and body armor) almost impossible to detect with sensory equipment under normal circumstances. The size and nature of the hovercycle is such that it is not as effective as a man in a suit, but it still does the job well, making the heat and radar signals that may be picked up difficult to interpret and identify accurately. Attempts to locate the hovercycle using radar, thermal-imaging (cannot be detected by thermal-imagers at ranges of 300 feet/91.5 m or more) and similar sensory devices incurs a penalty of -50% to the operator's Read Sensory Equipment skill. Note: To be effective, the pilot must also be wearing the Stealth body armor or similar suit that masks radar and heat, otherwise, sensors will easily key in on his body.

2. Remote Piloting Feature: A sophisticated combat program enables the cycle to fly independently, without any pilot, similar to a combat pod. Normally this feature is employed to summon the vehicle to its owner, which makes it excellent for quick get-aways and second-story work. To activate this feature the pilot must carry a cigarette lighter-sized remote, and homing module. The program enables the vehicle to recognize, locate and avoid targets at a skill equivalent of 86%, as well as hide and Prowl at 40% and Land Navigation 90%.

3. Sensor & Piloting Bonuses: The Shadow hovercycle is equipped with an advanced, computerized anti-collision radar that rapidly collates sensory data and displays the information on a heads-up-display to aid the pilot in high-speed maneuvers and evasive action. Add bonuses of +2 to initiative, +2 to dodge and +10% to piloting skill.

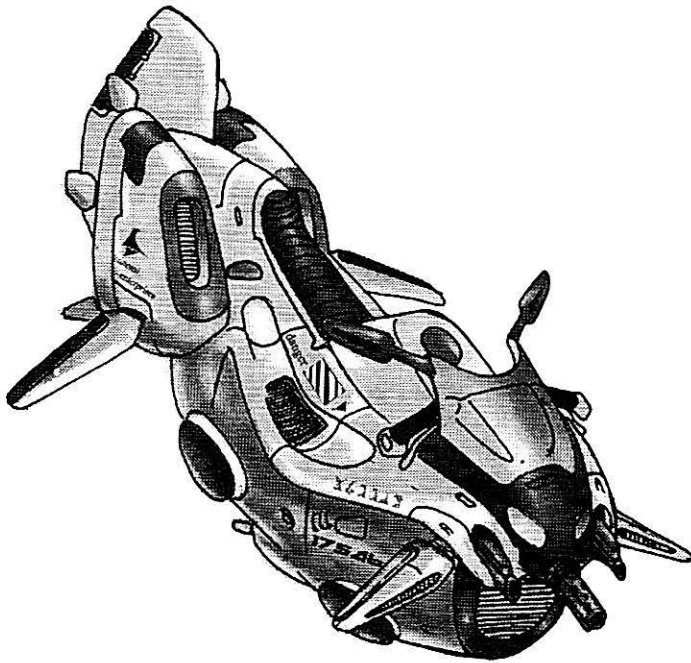

NE-HC-109 Combat Bike Nine

Also known as “Bike 9” and “Combat 9”

Combat Bike Nine was the working title during the design stage of this hovercycle and the name just stuck. This is a larger, heavier hovercycle that has good speed, a variety of weapons and excellent protection for the pilot. This hovercycle is built with adventuring and exploration in mind, making it an all-purpose combat vehicle. It is able to make pinpoint turns and to stop on a dime, hug the ground or take to the sky. In addition to its own body armor, Combat Bike Nine has a medium force field to protect the pilot, making it appealing to some practitioners of magic as well as adventurers and lawmen. City Rats find the vehicle too large and bulky to be appealing. Likewise, Juicers, Crazyies and Headhunters usually find smaller and/or faster hovercycles more “sexy” and appealing.

Model Type: NE-HC-109 Combat Bike.

Class: Combat Hovercycle.

Crew: One rider; no space for a passenger.

M.D.C. by Location:

- Large Jet Thrusters (2; rear) – 120 each
- *Small Hover Jets (6; side and underbelly) – 50 each
- Directional Hover Jets (8; tiny and concealed) – 5 each
- *Side Stabilizing Wings (4; small) – 20 each
- *Tail Fin (1; large) – 80
- *Forward Headlights (2) – 10 each
- *Forward Lasers (2) – 50 each
- *Plasma Cartridge Machine-Gun (1) – 55
- Windshield (1, optional) – 20
- **Main Body – 290
- ***Force Field – 200

* A single asterisk indicates small and/or difficult targets to hit and requires the attacker to make a “called shot,” but even then the attacker is -4 to strike. The driver, hunched down, low to the body of the hovercycle, is equally difficult to hit.

** Depleting the M.D.C. of the main body completely destroys the vehicle.

*** Depleting the M.D.C. of the force field temporarily shuts it down for eight hours as it regenerates 1D4 M.D.C. points per hour. As long as the force field is not reduced to zero, it regenerates M.D.C. at a rate of 1D6 points per minute. Weapons can only be fired when the force field is down.

Speed:

Flying: 300 mph (480 km), but cruising speed is considered to range from 40 to 100 mph (64 to 160 km). VTOL capable, it can hover stationary; retractable landing gear. Maximum altitude is limited to about 10,000 feet (3048 m).

Flying Range: The nuclear power supply provides the vehicle with decades of life, and can fly continuously for 18 hours without fear of overheating. Indefinitely with 15 minute breaks to cool down after every 4-6 hours of flight.

Statistical Data:

Height: 6 feet (1.8 m) to the top of the tail.

Width: 4 feet (1.2 m) wide.

Length: 7 feet (2.1 m).

Weight: 1000 lbs (450 kg).

Cargo: None.

Power System: Nuclear, average energy life is 20 years.

Market Cost: 7.3 million credits.

Weapon Systems: Weapons can only be fired when the force field is lowered.

1. **Medium Plasma Cartridge Machine-Guns (1):** A light plasma cartridge machine-gun is built into the nose of the hovercycle. It can rotate 45 degrees in any direction, but is usually left in a forward position. It is used primarily for aerial dogfights. This weapon is also used in rapid, devastating strafing runs against ground targets. It is fed rounds from an internal drum magazine.

Primary Purpose: Assault.

Secondary Purpose: Defense.

Mega-Damage: A single shot does 5D6 M.D. while a short burst of three rounds does 1D6x10 M.D.

Rate of Fire: A single shot or burst counts as one melee attack/action.

Range: 2000 feet (610 m).

Payload: The 900 round drum, provides 300 bursts. Reloading a drum takes about 5 minutes for those not trained, but just one minute by a trained soldier.

2. **Forward Lasers (2):** Built into the nose just behind and off to the sides of the machine-gun are a pair of medium lasers designed for distance and accuracy. They can move up or down by about 40 degrees but face forward.

Primary Purpose: Assaults and Aerial Dogfights.

Secondary Purpose: Defense and Anti-Missile.

Mega-Damage: 5D6 M.D. per single blast, or 1D6x10 M.D. per simultaneous, double barrel blast.

Rate of Fire: Each single or double blast counts as one of the pilot's melee attacks/actions.

Range: 3000 feet (914 m).

Payload: Effectively unlimited.

3. Missile Pod (1; optional): A mini-missile pod may be mounted in front of the tail.

Primary Purpose: Anti-Aircraft.

Secondary Purpose: Anti-Armor and Assault

Missile Type: Any mini-missile can be used, but we highly recommend K-HEX high explosive (1D4x10 M.D.), armor piercing (1D4x10 M.D.) or plasma (1D6x10 M.D.).

Mega-Damage: Varies with the missile type.

Rate of Fire: One at a time or in volleys of 2, 4, or 8.

Range: One mile (1.6 km).

Payload: 8 mini-missiles total.

4. Sensors & Features of Note: 1. Remote Piloting Feature:

A sophisticated combat program enables the cycle to fly independently, without any pilot, similar to a combat pod. Normally this feature is employed to summon the vehicle to its owner, which makes it excellent for quick getaways and second-story work. To activate this feature the pilot must carry a cigarette package-sized remote, and homing module. The program enables the vehicle to recognize, locate and avoid targets at a skill equivalent of 80%, as well as hide and Prowl at 30% and Land Navigation 90%.

2. Sensor & Piloting Bonus: The Combat 9 hovercycle is equipped with an advanced, computerized anti-collision radar that rapidly collates sensory data and displays the information on a heads-up display (HUD) to aid the pilot in high-speed maneuvers and evasive action. Add bonuses of +1 to initiative, +2 to dodge and +10% to piloting skill.

NE-DD6 "Rover" SUV

The Rover is a dependable all-terrain vehicle, or "jeep" as you humans call them. The NE-DD6 Rover is an open-topped vehicle that can be loaded with passengers and/or supplies. It can carry up to 1600 pounds (720 kg) and comfortably accommodates a driver and four passengers – 8-10 crammed in tightly. In addition, the Rover can pull up to 5 tons. Since this is an open-top jeep, passengers should wear body armor when in a combat zone.

If you're looking for an inexpensive, wheeled ground vehicle, the Rover is a real blast. It can navigate rugged terrain, drive down shallow chasms, roll over trenches, climb over broken chunks of debris or fallen trees, and zip up and down hills without difficulty. It can even ford water up to 5 feet (1.5 m) deep without fear of the engine choking, but the Rover is not waterproof and the passengers will get soaked. This is a solid, reliable vehicle that harkens back to a simpler day and age.

Model Type: NE-DD6 All-Terrain Rover.

Class: Military All-Terrain Ground Vehicle.

Crew: One driver and room to comfortably seat four passengers.

M.D.C. by Location:

Front Windshield – 15

* Headlights (2; front) – 6 each

* Wheels (6, front/middle/rear) – 25 each

** Main Body – 220

* Items marked by a single asterisk are small and/or difficult to strike. An attacker must make a "called shot," and even then the attacker is -4 to strike. Destroying three or more wheels will prevent the vehicle from steering properly (-50% to piloting skill), maximum speed is 20 mph (32 km), continuing to drive it does 3D6 M.D. to the axle (50 M.D.C.) per melee round, and it will get stuck in debris and mud. Significant parts and repairs are necessary.

** Depleting the M.D.C. of the main body completely destroys the vehicle.

Note: The All-Terrain Rover is built along the lines of an open-topped military jeep or humvee, so the pilot and passengers are always exposed to fire by an attacker. So those riding in the All-Terrain Rover should ALWAYS wear Mega-Damage body armor. An attacker must make a "called shot" and even then is -2 to strike to hit a passenger or the driver.

Speed:

Ground Speed: 220 mph (352 km) maximum. Cruising speed is a more cautious 90 mph (144 km) on clear terrain. The All-Terrain Rover can drive over most types of terrain, except for truly mountainous hills or water.

Flying: Not possible!

Underwater: Not possible!

Statistical Data:

Height: 6 feet (1.8 m).

Width: 6 feet (1.8 m).

Length: 13.3 feet (4 m).

Weight: 3600 pounds (1620 kg).

Cargo: Minimal storage space; about 4 feet (1.2 m) for additional clothes, helmet, body armor, supplies, weapons, or equipment in externally housed storage compartments in the rear.

Power System: Nuclear; average energy life is 25 years.

Cost: 80,000 credits for a gasoline based combustion engine; gets 25 miles per gallon; 500 per tank of fuel. Add 700,000 credits for an NE-EB battery system good for 72-96 hours of use per battery, or 1.6 million for a nuclear power supply with 20 year life.

Weapon Systems:

1. None, although several types of light, manned weapons can be mounted in the rear of the jeep for combat, including light rail guns, machine-guns, plasma cartridge weapons, mini-missile launchers, and light or medium laser, ion or plasma energy weapons. The rear weapon mounting can swivel 360 degrees and has a 90 degree arc of fire up and down. The weapon is typically fired by one of the passengers. One or two light weapons, such as a laser, can be mounted on the front of the vehicle, though they are typically fixed in a forward position and fired by the front seat passenger (the driver should stay focused on the task of driving). All weapon systems and mountings are sold separately.

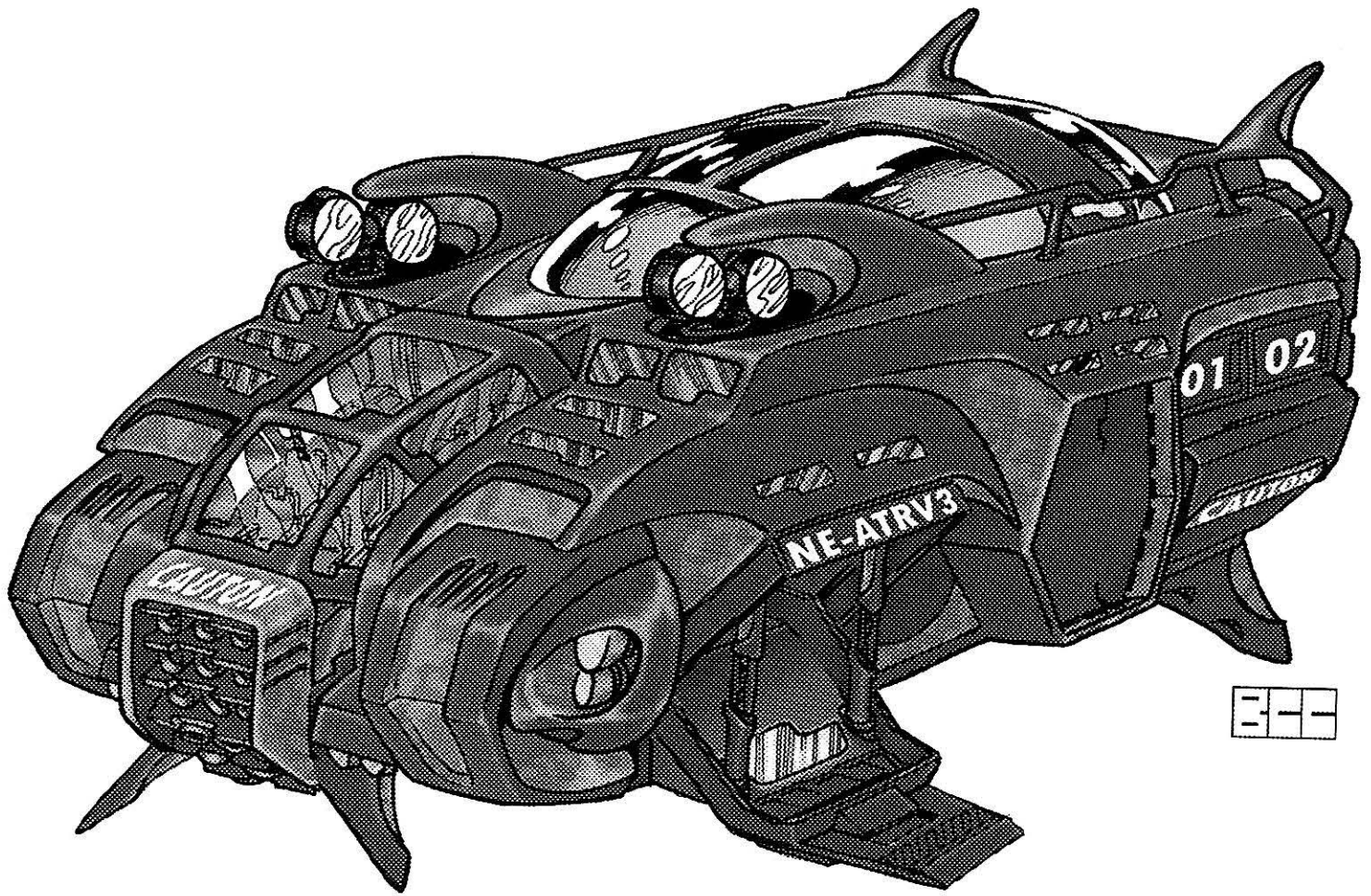

NE-ATRV3

Pathfinder All-Terrain RV

The Pathfinder is a huge hover RV with twelve individual sleeping quarters that can accommodate 24 people comfortably (48 cramped). The vehicle includes a large communal dining/lounge/observation area (the glass enclosure on top of the main body) where additional personnel can be accommodated under cramped conditions. Four storage bays can each hold one small vehicle like a motorcycle, hovercycle, rocket bike or jet pack, as well as a suit of man-sized power armor or additional cargo, equipment, spare body armor and ammunition, etc. The pilot compartment is located in the nose of the Pathfinder. The vehicle is mounted on a twin set of quad super hover jets, similar to those mounted on the NE-J2 Juggernaut hover tank, with one set in the front and the other in the aft/rear. In the middle of the armored vehicle are the exit doors and heavy cargo loading platform; two of each, one on each side.

The NE-ATRV3 was originally designed for exploration and wilderness adventuring for the people of the Three Galaxies. In recent years it has turned into a recreational vehicle that is often converted into a roomy mobile home for trips to alien worlds in comfort. "Converted" ATRV3-C's have half of the living quarters replaced with a kitchen, large dining room, living room, two private bathrooms, one or two lounge/studies and other conveniences that may range from a hot tub or game room to observatory or science lab, depending on the tastes of the individual purchaser. Bedrooms are also usually expanded from the simple,

military-style sleeping quarters of the standard vehicle to be more roomy and homey. Such converted mobile homes easily accommodate a family of 4-8 and as many as a dozen friends. Millions of the basic Pathfinder, and millions more converted into mobile homes, have been sold throughout the Three Galaxies and beyond.

For the Earth market, we've stayed with the basic exploration version of the vehicle. It is suitable for exploration expeditions, adventuring, public and personal transportation, as well as military operations. As a light combat vehicle, the Pathfinder can be used as an APC troop transport, long-term reconnaissance vehicle and even as a mobile base or light combat vehicle perfect for platoon-sized operations. It can also be modified and converted for use as a mobile lab, mobile field hospital or power armor transport.

Although some may find the NE-ATRV3 to be a little pricey compared to other APCs and similar exploration vehicles, the Pathfinder is superior in size, accommodations, armor protection and all-around versatility. As long as the planet has an atmosphere, the Pathfinder is an airtight and environmental enclosure with full hover vehicle capabilities. The standard model is an unarmed explorer, but a large range of weapons can be mounted to the exterior of the vehicle.

Model Type: NE-ATRV3 Pathfinder All-Terrain Recreational Vehicle.

Class: Heavy All-Terrain Personnel Hover Carrier.

Crew: Three: one pilot, one copilot, and a communications or science officer, but the pilot's compartment seats six (an entire

family or the core exploration or military team), and the standard vehicle can accommodate 24 to 48 passengers in addition to the crew and standard cargo.

M.D.C. by Location:

- Rear Personnel Hatches (2, one on each side) – 100 each
- Cargo Bay Doors & Ramp (2 forward, one on each side) – 180
- * Top Mounted Large Searchlights (2 pair) – 50 each
- * Forward Headlights (2) – 12 each
- * Forward Bank of Infrared Searchlights (1; nose) – 60
- Observation Deck (top, middle of the vehicle) – 200
- Reinforced Pilot's Compartment – 120
- Reinforced Passengers' Sleeping Compartments (12) – 80 each
- * Hover Jets (4 fore & 4 aft) – 100 each
- ** Main Body – 360

* A single asterisk indicates a difficult target to hit. An attacker must make a "called shot" to hit and even then he is -1 to strike. Destroying one of the hover jets (8 total; 4 fore and 4 aft) reduces speed by 10% with cumulative effect. Destroying more than five of the hover jets means that the vehicle crashes (1D4x10 M.D.) and is unable to fly.

** Depleting the M.D.C. of the main body completely destroys the vehicle.

Speed:

Ground Speed: The Pathfinder's hover capabilities enable it to hover stationary and cruise across the surface with good mobility and excellent speed. Height off the ground is typically 3-6 feet (0.9 to 1.8 m), but it can maintain greater heights. It has Vertical Take-Off & Landing (VTOL) capabilities, enabling the vehicle to hover stationary up to its maximum altitude or go up and over most obstacles. It has retractable landing gear in the underbelly.

Flying: 200 mph (320 km) maximum, but cruising speed is considered to range between 40 and 80 mph (64 to 128 km).

Maximum Altitude: 80 feet (24.4 m).

Water Speed: The Pathfinder can skim across the surface of water at a speed of 110 mph (176 km).

Underwater: 40 mph (64 km/34 knots).

Maximum Depth Tolerance: 4000 feet (1219 m).

Maximum Range: The nuclear power supply gives the vehicle decades of life, and the Pathfinder can be used continuously for 96 hours without fear of overheating, but after 120 hours the Pathfinder will shut down, due to heat build-up.

Statistical Data:

Height: 18 feet (5.5 m).

Width: 20 feet (6.1 m).

Length: 82 feet (25 m).

Weight: 23 tons (20,700 kg), but with empty cargo bay.

Cargo: 30 foot (9.1 m) storage area, 18 ton (16200 kg) limit.

Power System: Nuclear; average energy life is 25 years.

Cost: 12 million credits.

Weapon Systems: None. The Pathfinder is designed for exploration and recreational purposes (i.e., a high-tech mobile home). However, most basic types of weapon systems, turrets and sensor clusters can be added to the outer hull of the Pathfinder, including rail guns, mini-missile launchers and energy weapons. No more than four are recommended, and carrying heavy loads

of ammunition as well as air drag from large guns may reduce speed by 30% and require sacrificing living and cargo space.

Aggressor Mark II Hover Assault IFV

By Patrick Nowak & Kevin Siembieda

The Aggressor is a heavily armored, Infantry Fighting Vehicle (IFV) that provides similar speed, mobility and firepower (including a similar big gun mounted on a heavy turret, and secondary weapons) to the Carnivore Mark I, but with a modified chassis to accommodate a larger crew, a squad of ten, and heavier armor. This vehicle has a longer body to allow for a troop compartment in the rear section of the vehicle. Like the Carnivore, this combat vehicle has a fast and agile hover propulsion system that allows the Aggressor to keep up with slow moving aircraft and power armor units, winged monsters and most commercial vehicles. The hover system enables the IFV to cross obstacles and travel over broken terrain that would stop most conventional wheeled vehicles.

Ideal for mercenary companies, independent kingdoms and wealthy adventurers in need of a fast, agile, heavy hitting tank. This vehicle can keep up with most other ground vehicles and can offer the support and protection combat squads need in hostile territory.

Model Type: N-IFV1

Class: Infantry Fighting Vehicle.

Crew: Five: one driver, two gunners, one communications officer and crew commander.

Troop Transport: The troop compartment can hold 10 fully equipped humanoid troops dressed in regular body armor, or 5-6 troops in light power armor such as the NE Earth or Space Angel and Tech-Warrior, as well as competitor armor such as the Flying Titan, Samson, T-21 Terrain Hopper, NG Gladius or SAMAS (excluding the Super-SAMAS).

M.D.C. by Location:

- Particle Beam Cannon (1; main turret) – 90
- Mini-Missile Launcher (1; main turret, rear) – 60
- * Sensor Rod (1; main turret) – 20
- * Headlights (2; front) – 5 each
- Main Turret (1) – 200
- Hover Jets (5; underbelly) – 50 each
- Side Hover Jets (2) – 150 each
- * Plasma Cartridge Coaxial Machine-Gun (front, fixed forward) – 75
- ** Main Body – 550
- Reinforced Pilot and Crew Compartment – 140

* A single asterisk indicates a difficult target to hit. An attacker must make a "called shot" to hit and even then he is -3 to strike. Destroying one of the hover jets (5 total in the underbelly) reduces speed by 15% with cumulative effect. Destroying a side hover jet reduces speed by 20% each.

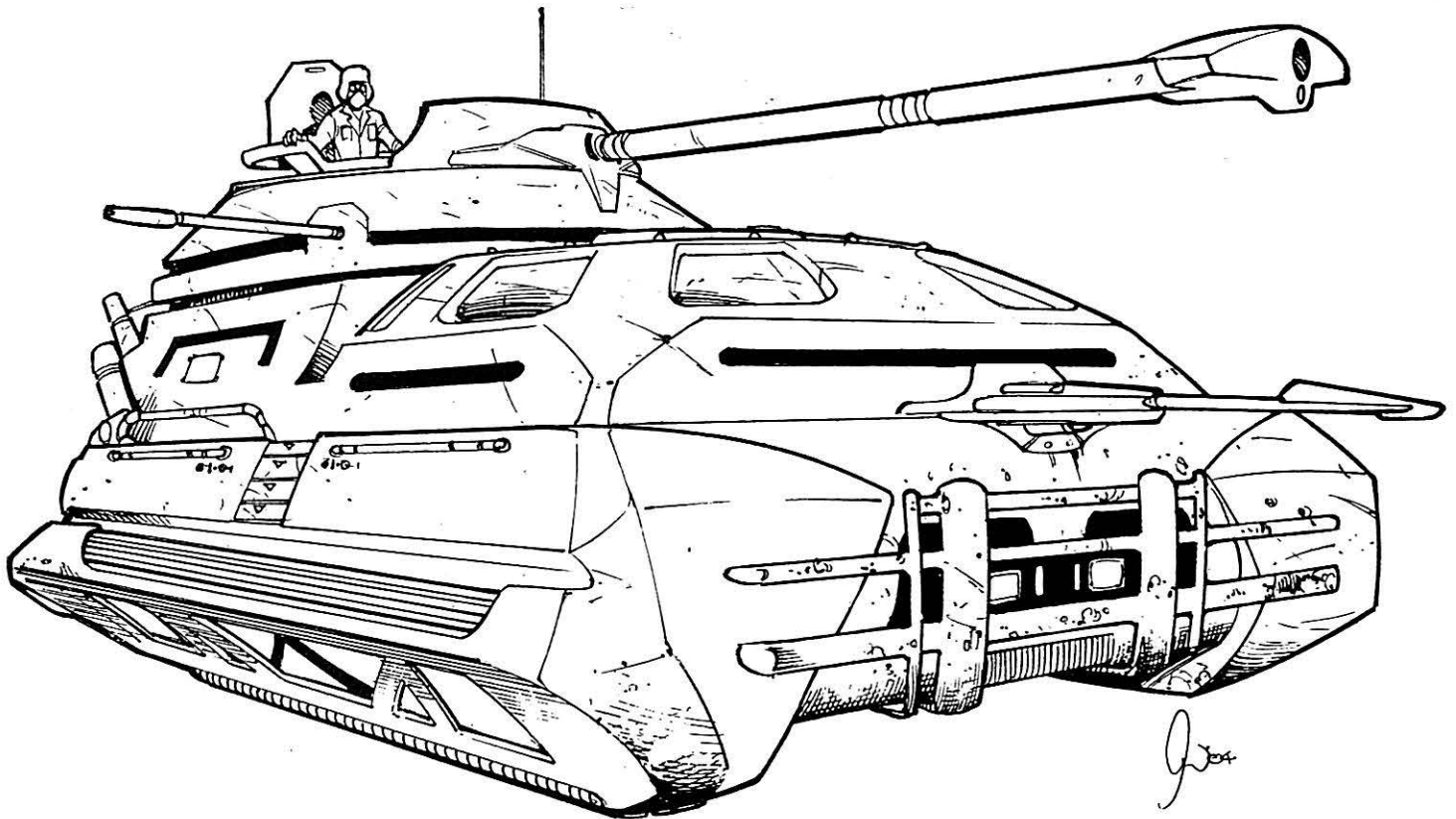

** Depleting the M.D.C. of the main body completely destroys the vehicle. Knocking out the main turret prevents the use of all its weapon systems, except for the coaxial plasma machine-gun.

Speed: 180 mph (288 km) maximum speed. Can travel over ground and water, but cannot lift itself above 15 feet (4.6 m) off the surface.

Statistical Data:

Height: 14 feet (4.3 m).

Width: 11 feet, 6 inches (3.5 m).

Length: 40 feet, 6 inches (12.3 m).

Weight: 27 tons fully loaded.

Cargo: 6x6 foot (1.8 x 1.8 m) compartment, plus a small weapons locker that holds three rifles, five pistols, a rocket launcher and signal flares.

Power System: Nuclear; average energy life is 20 years.

Market Cost: 45 million credits.

Weapon Systems:

1. **Particle Beam Cannon:** This is a very powerful artillery piece built into the main turret. It requires so much energy that its payload is limited, drawing energy from a capacitor that must be recharged after a number of shots. The main turret can rotate 360 degrees and the P-beam cannon can be raised and lowered in a 90 degree arc of fire. The cannon is typically operated by the gunner, but can also be fired by the crew commander.

Primary Purpose: Anti-Armor/Robot and Anti-Dragon.

Secondary Purpose: Defense.

Weight: 1.2 tons.

Mega-Damage: 1D6x10 M.D. per single blast, or 3D6x10 M.D. per multiple pulse burst (three simultaneous shots).

Rate of Fire: Each shot counts as one of the gunner's attacks per melee round.

Range: 4000 feet (1219 m).

Payload: 30 shots before the capacitor must be recharged. The power supply recharges the gun at a rate of one shot per melee round (the weapon cannot be used that round). This means if locked in combat, once the 30 rounds are fired, the tank can only fire the particle beam cannon once every other melee round.

2. **Mini-Missile Launcher:** A multi-tube missile launcher is built into the rear of the main turret. The launcher is typically operated by the primary gunner with the secondary gunner as backup.

Primary Purpose: Anti-Vehicle and Anti-Personnel.

Secondary Purpose: Defense and Assault.

Missile Type: Any mini-missile can be used, but Naruni Enterprises encourages the use of the high-powered K-HEX high explosive (1D4x10 M.D.), armor piercing (1D4x10 M.D.) or plasma (1D6x10 M.D.).

Mega-Damage: Varies with missile type.

Range: One mile (1.6 km).

Rate of Fire: One at a time or volleys of 2, 4, 6 or 8 missiles.

Payload: 24 missiles total.

3. **NE-200 Plasma Cartridge Coaxial Machine-Gun:** Built into the front of the IFV, in the nose of the tank, is a coaxial NE-200 machine-gun. It points forward and can only move in a 30 degree arc of fire up and down or side to side. It is typically controlled by the secondary gunner, but can be controlled by the first gunner or even the driver if the gunner is injured.

Primary Purpose: Anti-Personnel.

Secondary Purpose: Defense.

Mega-Damage: 5D6 M.D. for a single shot, or 2D4x10 M.D. for a six round burst.

Rate of Fire: Each shot or burst counts as one melee attack of the gunner.

Effective Range: 4000 feet (1219 m).

Payload: 1000 rounds, that's 166 bursts. The ammunition is medium plasma cartridges in disintegrating link belts fed from an internal drum magazine.

New Aircraft

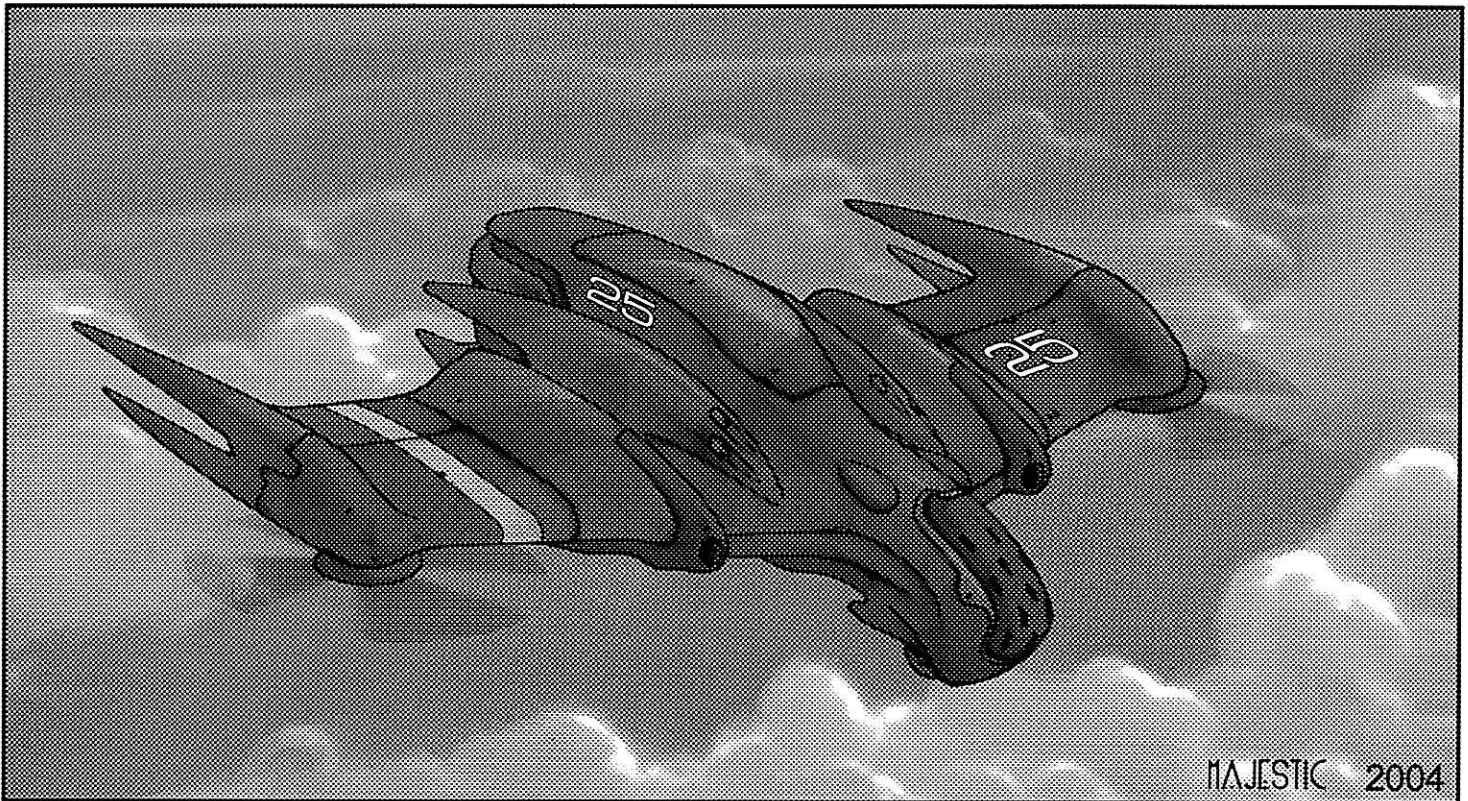

NE-J-TA15 "Javelin" Combat Transport Aerodyne

Naruni Enterprises has learned that commercial aircraft in North America are a rarity, and combat aircraft are exclusive to only the most powerful or luckiest kingdoms in the land. Well, we hope to change all that starting with the NE-J-TA15 Javelin. The Javelin is a high speed aerial transport used to move men and equipment rapidly around the battlefield in airborne cavalry style operations. The Javelin is lightly armed for speed and maneuverability, but has enough weapons to kick an enemy in the teeth when necessary. That having been said, the Javelin can NOT hold its own for long when facing true combat aircraft or a squad of aerial power armor.

The Javelin is of a unique design with a propulsion system on the bottom, like its fighter brethren the Boomerang. The three

engines work like a helicopter's main rotors in reverse, pushing rather than pulling the Javelin through the air. As a result, the aerodyne is less vulnerable to attack, and, when necessary, the crew can bail out without getting shredded in the rotor blades. Note that the Javelin actually only needs one propulsion system to keep flying, but has three for greater lift capacity and redundancy in case of damage. If one or two are lost, however, it gets progressively harder to control the Javelin, as it wants to pitch and flip out of control; speed is also diminished.

Model Type: NE-J-TA15 Javelin Combat Transport Aerodyne.

Class: Transport Aerodyne.

Crew: Four, a pilot, a navigator, a communications officer, and a gunner. It can hold and transport 25 troops, 40 in cramped conditions (half if power armor troops).

M.D.C. by Location:

* Wing Mini-Missile Launchers (2) – 100 each

* Propulsion Systems (3) – 120 each
Wings (2) – 170 each
Reinforced Pilot's Compartment – 100
Nose Section (forward) – 150
** Main Body – 400

** Depleting the M.D.C. of the main body completely destroys the vehicle. Destroying all propulsion systems will incapacitate the craft, but it can glide down to a safe landing. **Note:** The propulsion systems are well shielded and difficult to hit, especially on a moving target. Thus, they can only be struck when an attacker makes a "called shot," and even then the attacker is -3 to strike. The loss of one inflicts a piloting penalty of -15% and reduce speed by 30%, double the penalties if two are lost, and the aircraft must immediately make emergency landing if all three are destroyed.

Speed:

Ground Speed: The Javelin cannot drive on land, but it is Vertical Take-Off & Landing (VTOL) capable and can hover stationary up to its maximum altitude. Has retractable landing gear.

Flying: 440 mph (704 km), but cruising speed is considered to range from 150 to 300 mph (240 to 480 km).

Maximum Altitude: 10,000 feet (3048 m) and the vehicle can fly as low to the ground as 50 feet (15.2 m), provided there are no obstacles in its path, or at tree top level to fly under most enemy radar systems.

Underwater: Not possible!

Maximum Range: Unlimited. The Javelin does not overheat (its propulsion system is like three giant cooling fans all spinning together). The only limit is the pilot's endurance.

Statistical Data:

Height: 18 feet (5.5 m).

Width: 53 feet (16.1 m).

Length: 60 feet (18.3 m).

Weight: 13 tons (11,700 kg).

Cargo: 20 feet (6.1 m) of storage area, 30 ton limit.

Power System: Nuclear, average life is 20 years.

Cost: 36 million credits.

Weapon Systems:

1. **Mini-Missile Launchers (2):** Wing-mounted mini-missile launchers.

Primary Purpose: Anti-Personnel and Anti-Aircraft.

Secondary Purpose: Self-Defense.

Mega-Damage: Varies with mini-missile type. Any mini-missiles can be used, but Naruni Enterprises recommends plasma (1D6x10 M.D.) or armor-piercing (1D4x10 M.D.). Fragmentation (1D4x10) will be used for anti-personnel operations.

Rate of Fire: One at a time or volleys of 2, 4, 6 or 8 mini-missiles.

Range: About 1 mile (1.6 km).

Payload: 24; 12 missiles per launcher.

NE-NS74 "Quad-Wing"

The Quad-Wing is a multi-purpose, one-man, light air to land assault and reconnaissance system, much like the Coalition States' Death Wing or the Icarus Flight System. The Quad-Wing is part Contra-Gravity generator, part jet pack and part flying wing. A fully assembled unit has a wingspan of about 20 feet (6.1 m), is capable of Vertical Take-Off and Landing (VTOL), and can attain extremely high altitude where it can fly unseen by ground troops and observe subjects below through telescopes without them knowing it. Its small size and low profile make it indistinguishable on radar from a small flock of birds or power armor. Furthermore, the Contra-Gravity system and small size enable its pilot to slip under most radars, fly at treetop level and even skirt the ground as low as three feet (0.9 m) from the surface. It has impressive speed, agility, mobility and high altitude capabilities that elude most types of power armor and even light aircraft. Its speed is fast enough to keep up with most Earth jet fighters, at least for a short time.

The Quad-Wing was inspired by a Death Wing brought back by sales rep, Trader Joe (of Robot Control). Our engineers were impressed by such an inventive idea, a one-man, enhanced jet pack with the firepower of a jet fighter. The engineers dismantled and studied the Death Wing before devising what we feel is a superior machine. The Death Wing and manned vehicles like it, was too unstable, fast and dangerous except for daring pilots with lightning reflexes and the endurance to survive the G-forces. This made it suitable only for Juicers, Crazies, 'Borgs, light power armor, supernatural creatures or similarly augmented individuals. That all changes with the Quad-Wing.

G-forces have been knocked out of the equation by incorporating the Contra-Gravity generator system into the Quad-Wing. Furthermore, pilot vulnerability has been reduced by adding an integrated NE-F40A Heavy Force Field. With the Contra-Gravity generator, even a normal human can operate the Quad-Wing without fear of flying out of control or crashing, and the force field eliminates the distraction of being open to attack. The only trade-off is that the Quad-Wing has to physically land for the pilot to unhook himself from the vehicle. Though the Contra-Gravity system can carry its pilot into the reaches of outer space, a fail-safe mechanism intercedes to top the ascent at 40,000 feet (12,192 m). Disabling the fail-safe mechanism burns out the circuits and disables the vehicle. Only a licensed Naruni mechanic has the proper tools, parts and know-how to repair the unit when this happens.

The wing is laid out in a different pattern than the other one-man flying wings, with four wings that open to form an "X" pattern for combat, treetop or ground level flight, and maximum maneuverability. The wings close together to form a single pair of wing for the vehicle to attain maximum speed and altitude. The Quad-Wing can not be disassembled like the others models, but is able to fold down into a 6 by 6 by 6 foot (1.8 by 1.8 by 1.8 m) package for ease of ground transport.

The last job of the engineers was to lay out a suitable weapons package that could give the Quad-Wing the widest possible array of combat options. As a result, the vehicle was given a single laser for distance and accuracy and a pair of mini-missile launchers to deal with heavy threats, hardened positions and anti-aircraft operations. The pilot can also carry and drop or

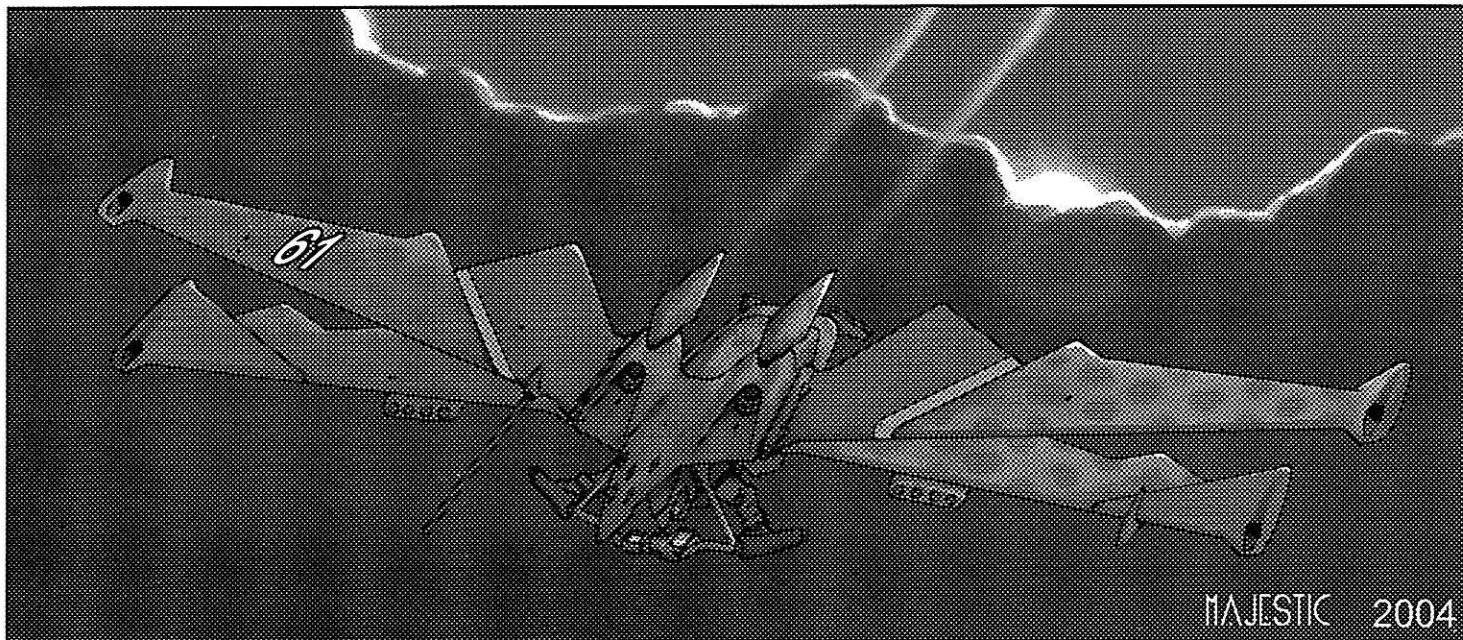

throw hand grenades like bombs as well as use any type of hand-held weapon as desired, however, the Quad-Wing's own integrated firepower makes carrying a handheld weapon unnecessary.

The wing jet pack is attached to the pilot's body armor by a special magnetic seal, and can be removed in a matter of seconds (attaching to/detaching from the Quad-Wing counts as one melee action). The moment the magnetic seals lock, the flying wing's NE-F40A Heavy Force Field comes on to protect the pilot. This connection gives the pilot complete control over the entire wing, its engines, speed and weapons. The wing's computer responds to verbal commands and codes as well as manual override. Unlike the other flying wings, the pilot cannot jump up into the wing during flight. The Quad-Wing can also be remotely controlled just like the Death Wing or Icarus, however, there is no possibility for Juicer acrobatics or leaping from it in mid-flight while the wing continues to attack. Experienced pilots can use remote control to make the Quad-Wing fly and attack without a pilot being on board, though they must direct it using line of sight while they hide among ground cover at a safe distance.

The Quad-Wing is best suited for aerial combat, scouting/reconnaissance, escort, air to ground patrols, high-speed travel, power armor combat and air to ground engagements. The Quad-Wing's wide wingspan makes it virtually impossible to fly through woodlands without smashing into or through trees and tree branches. Striking large trees can cause weapons to become misaligned (-1D6 to strike) or bent (cannot shoot), scratch and dent the Mega-Damage wings, and create a terrible ruckus. Moreover, the pilot may become injured by collisions and the smashing through trees and branches creates a huge amount of noise heard for miles. Injury to the pilot may include bruises and other minor damage, to broken bones, loss of consciousness and concussion. The thunderous noise alerts humanoids and monstrous predators to the pilot's location and the wings cut a trail that is easy to follow. In open fields the Quad-Wing can hug the ground, take evasive action and attack with long-range weapons.

Model Type: NE-NS74 Quad-Wing Flying Wing.

Class: One-Man Flying Wing Combat System.

Crew: One.

M.D.C. by Location:

- * Jet Thrusters (2) – 50 each
- * Wing Mini-Missile Launchers (2 or 4) – 20 each
- * Wing Lasers (4; wing tips) – 25 each
- * Sensor & Communications Rod (1) – 15
- * Pilot – As per Force Field (110 M.D.C.) and body armor (varies).
- Wings (4) – 120 each
- ** Main Body of Wing – 220

* A single asterisk indicates small or otherwise difficult targets to hit. A "Called Shot" is needed to hit it and the shooter is -4 to strike. The pilot of the Quad-Wing is in the open, and can be targeted by a "Called Shot." However, he is a small target protected by the wings and main body, making him a difficult target to hit (the same -4 to strike on a Called Shot). The pilot's M.D.C. body armor protects as normal, but damage is first subtracted from the force field (110 M.D.C.). Killing the pilot will cause the wing to switch to autopilot and return to its base of origin at maximum speed. The wing's computer constantly monitors the pilot and knows when he is severely injured or dead. The same happens if the pilot gives a homing command (return to base) or falls unconscious. The pilot can designate any point as "home" for the wing.

** Depleting the M.D.C. of the main body destroys the wing and causes it to crash. Destroying one wing (120 M.D.C.) will not cause the flying wing to crash, but it will inflict a penalty of -10% to piloting rolls, -1 on initiative, -1 to dodge and reduce speed by 10%. Even if all four wings are destroyed, the Contra-Gravity system keeps it airborne, though at half the usual maximum speed. Destroying the main body destroys the Contra-Gravity system, because it is buried right in the middle of the main body with no visible parts exposed.

If the M.D.C. of the force field is depleted, it cannot be reactivated again for 12 hours. As long as the force field's M.D.C. has not been reduced to zero, it regenerates lost M.D.C. at the rate of one point per melee round (that's four M.D.C. points per min-

ute). Otherwise, the force field cannot be activated at full strength (all M.D.C.) until after 12 hours have passed.

Speed:

Ground Speed: The Quad-Wing cannot drive on land, but the pilot can walk unencumbered, due to the Contra-Gravity field, making the jet pack and wings as light as a feather.

Flying: Contra-Gravity system allows for flight at up to Mach One (670 mph/1072 km)! The Contra-Gravity system also means that G-forces and stress placed on the pilot are not an issue and anyone can fly the wing, because those stresses are totally negated by the Contra-Gravity field. Cruising speed is usually 200 to 400 mph (320 to 640 km); VTOL capable. The Contra-Gravity system enables the Quad-Wing to hover in stationary position at any altitude up to 40,000 feet (12,192 m). The pilot can punch in a booster for the Contra-Gravity system, up to Mach three (2010 mph/3216 km) when in an atmosphere, but this speed can only be maintained for 2D4 minutes before the Quad-Wing must slow down to rest the generator. The Quad-Wing can reach speeds of up to Mach 16 (10,720 mph/17,152 km) in outer space without needing to rest the generator, but the Earth models have a fail-safe system that prevents the vehicle from rising more than 40,000 feet (12,192 m) to avoid accidental fatalities in space.

Maximum Altitude: Normally unlimited, but the Quad-Wing is specifically designed for use by Earthlings and has a fail-safe system that stops the wing from reaching any altitude above 40,000 feet (12,192 m). The Quad-Wing can also fly as low as two feet (0.6 m) above the ground with the pilot in a prone/flat position. Sensors enable the Quad-Wing to follow the contour of the ground while adjusting and maintaining the two foot (0.6 m) height even at maximum speed, although most pilots seldom dip below treetop level unless in open ground. Flying in the prone/flat position makes the wing and especially the pilot, difficult to shoot due to the high rate of speed and low profile (-7 to hit the pilot and -2 to hit the Quad-Wing in general when this low to the ground). Flying at treetop level or below six feet (1.8 m) in open ground puts the pilot under most radar systems and he can travel unseen by radar systems.

Underwater: Maximum speed of 50 mph (80 km) using the Contra-Gravity system, but the pilot had better have an air supply.

Maximum Depth Tolerance: 4000 feet (1219 m) for the mechanical parts, but limited by the pilot's depth tolerance, which is 160 feet (48.7 m) for most humans.

Maximum Range: Unlimited. The Contra-Gravity system does not overheat. The only limit is the pilot's endurance.

Statistical Data:

Height: About one foot (0.3 m) taller than the wearer (each suit is adjusted to the height of the pilot).

Width/Wingspan: 20 feet (6.1 m).

Length: 3 feet (0.9 m).

Weight: 1.1 tons (990 kg).

Cargo: None; basic armor and gear up to 500 pounds (225 kg).

Power System: Nuclear, average life is 15 years.

Cost: 12.5 million credits.

Weapon Systems:

1. Wing Tip Lasers (4): A high-powered laser is built into the tip of each wing. These weapons point forward but move within their recessed housing 40 degrees in any direction, and can all point together at a single target. They are also used to strafe ground targets and engage in dogfights with power armor and other, small, light flying targets.

Primary Purpose: Anti-Aircraft.

Secondary Purpose: Anti-Personnel.

Mega-Damage: 2D6 M.D. per single blast, 4D6 per double blast, 6D6 M.D. per triple blast and 6D6+8 per focused quadruple blast.

Rate of Fire: Each individual blast or simultaneous multiple blast (2, 3, or 4 lasers shooting simultaneously at the same target) counts as "one" of the pilot's melee attacks.

Range: 2000 feet (610 m).

Payload: Effectively unlimited.

2. Wing Mini-Missile Launchers (2 or 4): Comes standard with one mini-missile launcher mounted on each of the lower wings. One can also be mounted on the two top wings, but are sold separately at an additional cost of 100,000 credits each. All work as part of an interconnected system.

Primary Purpose: Anti-Armor and Anti-Aircraft.

Secondary Purpose: Self-Defense and Ground Assault.

Mega-Damage: Varies with mini-missile type. Any mini-missiles can be used, but standard issue is plasma (1D6x10 M.D.) or armor-piercing (1D4x10 M.D.). Fragmentation (1D4x10 M.D.) may be used for anti-personnel operations.

Rate of Fire: One at a time or volleys of 2, 4, 6 or 8 mini-missiles.

Range: About 1 mile (1.6 km).

Payload: 16 to 32; 8 mini-missiles per each launcher (2 or 4).

3. Camouflage System: The Quad-Wing can change colors to match the background to help make it invisible in the sky. Its low profile also makes it resistant to radar interpretation (operator is -10% on his skill to Read Sensory Equipment).

4. Handheld Weapons: The Quad-Wing pilot typically has an ordinary survival knife and a Vibro-Knife locked and concealed in the boots. An energy rifle can be slung over the chest and a side-arm at the waist, but in both cases, flying at speeds above 350 mph (560 km) is likely to pull the weapons loose (or out of one's hand), causing them to fall to the earth.

5. Combat Bonuses: Anyone with the Flight System Combat skill gets a special bonus of +2 on initiative, +3 to auto-dodge (they are that quick) and one additional attack per melee round when piloting the Quad-Wing.

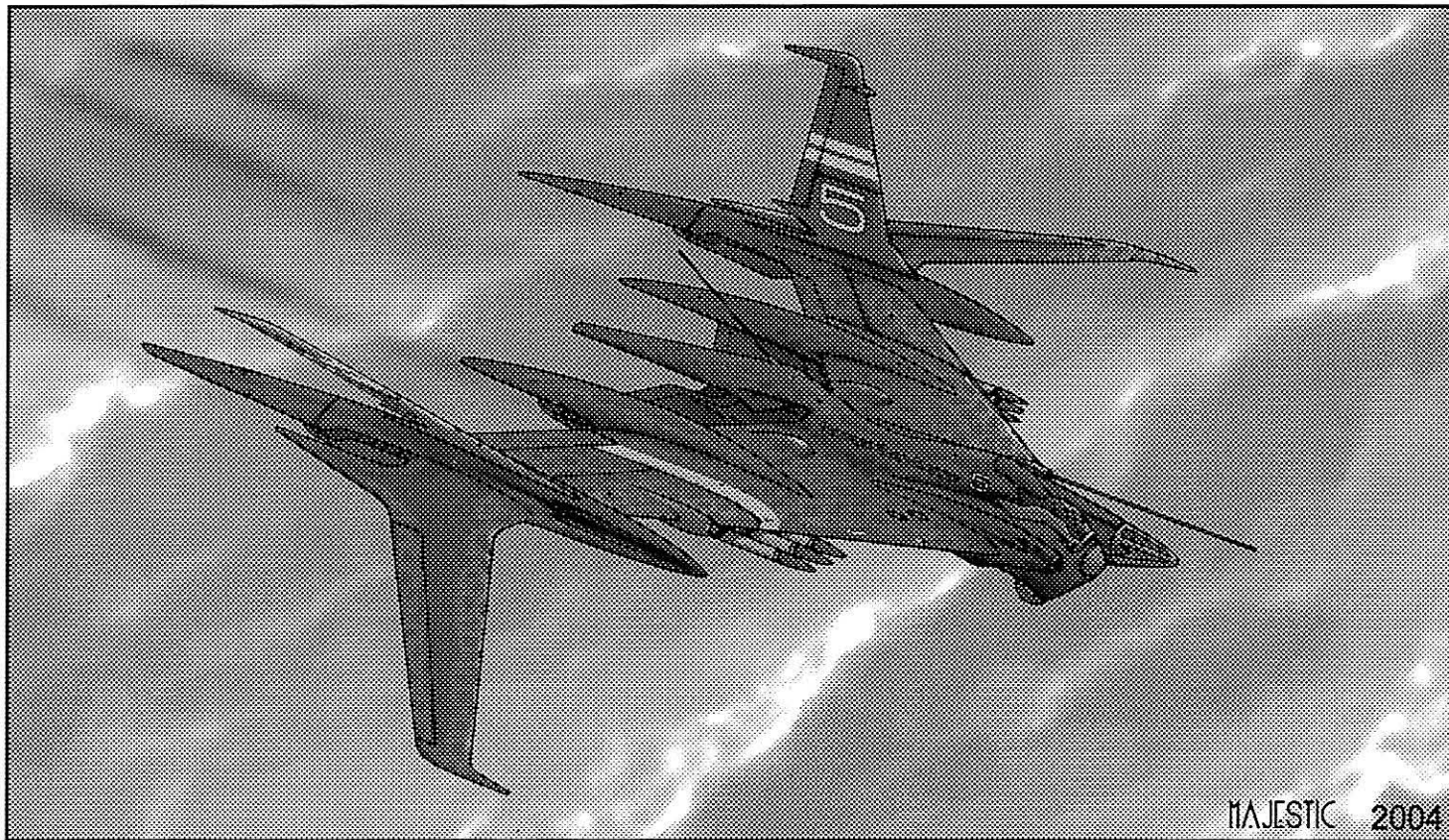

NE-SDSR-2000 Star Dragon Superiority Fighter

Naruni Enterprises' Star Dragon Superiority Fighter is one of the most sophisticated, agile and capable aircraft on Earth. This vehicle is designed for both atmospheric and space combat (the Star Dragon can safely enter an atmosphere from space). It is manufactured primarily for clients in the Three Galaxies and other similar environments with FTL level technology. However, Naruni Enterprises is offering a limited number to the first dozen clients who can afford one. Just think what a crusader against the Coalition States could do with this amazing combat vehicle.

The Star Dragon can seat as many as five passengers but requires only one pilot, making it one of the largest and fastest one-man combat vehicles in the world. It can fly circles around virtually every aircraft in North America. Central to the fighter's design is a series of maneuvering vector jets which enable the aircraft to stop on a dime (well, almost) and to make pinpoint turns, rolls, dives and maneuvers. A computerized system controls these vector jets, propelling the craft through precision turns much tighter than any Earth jet plane can perform. There are 16 such vector jets positioned in various locations around the fuselage, including several redundant fighter so that the jet can continue to function at optimal performance even if reduced to just 10 vector jets.

Furthermore, the Star Dragon is outfitted with a host of incredibly sophisticated combat computers and sensor systems far more advanced than anything on Earth. These systems are controlled by an artificially intelligent targeting & weapons computer

which responds to the pilot's voice commands. Apart from normal radar and optical systems, the craft is equipped with a thermographic system that is far more precise than the most advanced thermal imaging system on Earth, radiation sensor and long-range motion detector. It also has a gravity-wave sensor that is capable of detecting other aircraft in the depths of space up to a range of 200,000 miles/320,000 km (unfortunately, this sensor does not function in atmosphere). Plus the Star Dragon is furnished with a battery of modern, long-range weapon systems.

With all of its advanced avionics, computers and vectored maneuvering system, the Star Dragon does have one inherent problem. The jet fighter is too advanced for a normal human pilot with average reflexes and hand-eye coordination to fly it at optimum performance levels. Only augmented pilots or D-Bees with superhuman reflexes like the Hyperion Juicer, Quick-Flex Alien and others with fast reflexes can fly the aircraft without the assistance of specialized training. Special training can only be provided by authorized Naruni Enterprises dealers. It entails virtual reality, subliminal programming of the human subconscious mind to allow it to handle the enormous streams of data fed to the pilot from the HUD and to react quickly enough to perform even basic piloting maneuvers. The training takes about 26 hours and costs approximately 1.2 million credits. This means that only a pilot with this training can fly the Star Dragon, and if killed he cannot be easily replaced. **Mercenary Pilot Note:** The sole exceptions to the above rule are the Mercenary Pilot and Turbo-Pilot O.C.C. with their instinctive piloting ability. These characters are able to fly the Star Dragon at their base ability percentage, but with a -10% penalty, and with all O.C.C. bonuses, bonuses from jet fighter combat and those from the aircraft itself, at half. However, after 120 hours of flight time, these pilots will be able to self-teach themselves to fly the Star Dragon without any penalties.

Admittedly, Star Dragon fighters are extremely expensive and may have limited value, as the Coalition States are certain to send their every available resource to destroy one whenever it is identified. Ah, but this simply makes the use of the Star Dragon all that much more exciting and challenging. Clever and cunning deployment of this fighter can deliver a devastating blow to one's enemies when the proper strategy and tactics are deployed. One Star Dragon is easily a match for any 4-6 Earth-made jet fighters and can break through even Coalition airspace before the CS knows what's upon them.

Model Type: NE-SDSF-2000

Class: Space/Atmospheric Superiority Fighter.

Crew: Four: Pilot, laser cannon gunner, rail gunner, and navigator/communications officer, plus four additional passengers.

M.D.C. by Location:

Pulse Laser Cannon (1; side of cockpit) – 120

* Rail Gun Turret (1; bottom of cockpit) – 90

* Medium-Range Missile Pylons (8, four per wing) – 20 each

* Mini-Missile Pylons (16) – 10 each

Main Jet Thrusters (4; rear) – 160 each

* Maneuvering Vector Jets (16) – 20 each

* Communications Antenna (1) – 25

** Wings (2) – 290 each

Pilot's Compartment – 150

** Main Body – 500

* Targets marked with a single asterisk are small and difficult targets to hit, requiring a called shot at -3 to strike.

** Destroying one of the wings or depleting the M.D.C. of the main body will knock the bird out of the sky! Roll under piloting skill at -40% for a successful crash landing (see optional tables under skill description).

Speed

Atmospheric Flying: Maximum speed in atmosphere is Mach 2.5 (or 1675 mph/2680 km). The fighter is capable of supersonic cruising at a speed of Mach 1 (670 mph/1072 km). The maximum atmospheric altitude of the Star Dragon is 70,000 feet (21,336 m). It is not capable of reaching Earth orbit without the use of a special booster rocket, which is not made available on Earth models.

Atmospheric Range: The nuclear power supply gives the fighter 20 years of life, but the jets need cooling after 24 hours of continuous use at cruising speed, or ten hours at maximum speed.

Space Flight: Mach 12. Flying range in space is limited only by the endurance of the pilot and life-support systems (life-support will last 18 days). At an additional cost, the craft can be equipped with an FTL stardrive which allows the Star Dragon to travel at three light years per hour. Due to air friction it is impossible to fly at space flight speeds in atmosphere conditions.

Statistical Data:

Height: 18 feet (5.5 m).

Width: 80 feet (24.4 m).

Length: 56 feet (17 m).

Weight: 16 tons.

Cargo: A small area typically containing an energy rifle, handgun, 1D4 signal flares, canteen, first aid kit and basic survival gear.

Power System: Nuclear, the average energy life is 10 years.

Market Cost: 98 million credits for a brand new Star Dragon with complete weapon systems plus the specialized training required to fly the craft effectively. An FTL stardrive costs an additional 6 million credits on Earth, and the reusable (can be recovered by a space shuttle) space booster which allows the craft to reach orbit from planet-side costs an additional 4 million credits. **Note:** These two options are not available on Rifts Earth. Naruni Enterprises is very selective about which clients may purchase the Star Dragon. The kingdom of Tolkeen had purchased three Star Dragons for its small air force. Two are accounted for, destroyed in the final siege before they could get off the ground, but one is missing.

Weapon Systems:

1. **Pulse Laser Cannon Pod (1):** A high-intensity laser pulse cannon is mounted in a turret on the side of the cockpit. A gunner seated in a compartment on the left side of the cockpit operates the weapon. The laser cannon can move 30 degrees in all directions to fire, but is otherwise in a forward position.

Primary Purpose: Anti-Aircraft.

Secondary Purpose: Defense.

Mega-Damage: 1D4x10 M.D. per single blast, or 2D4x10 M.D. for a simultaneous three shot pulse.

Rate of Fire: Each blast or pulse counts as one of the pilot's melee attacks.

Range: 6000 feet (1829 m).

Payload: Effectively unlimited.

2. **Rail Gun Turret (1):** A pair of powerful rail guns are mounted in a turret under the cockpit. The turret is operated by a gunner seated under the nose. The turret is capable of 360 degree rotation and has a 120 degree arc of fire.

Primary Purpose: Assault.

Secondary Purpose: Anti-Aircraft and Defense.

Mega-Damage: A single burst is 20 rounds and inflicts 2D4x10 M.D., or a double burst from both guns simultaneously at the same target (40 rounds) does 4D4x10 M.D. Only fires bursts.

Rate of Fire: Each burst counts as one of the gunner's melee attacks.

Range: 6000 feet (1829 m) in atmosphere. Maximum range is tripled in outer space.

Payload: 10,000 rounds, that's 500 single bursts or 250 double bursts.

3. **Medium- or Long-Range Missile Launchers (8):** Four medium- or long-range missile can be mounted on each wing.

Primary Purpose: Anti-Aircraft and Anti-Fortifications.

Secondary Purpose: Assault and Defense.

Missile Type: Any medium- or long-range missile can be used

Mega-Damage: Varies with the missile type. Medium-range is typically 2D6x10 or 3D6x10 (not nuclear) and long-range is typically 4D6x10, 5D6x10 or 6D6x10 (not nuclear).

Rate of Fire: One at a time or in volleys of two or four.

Range: Medium-range: 40-60 miles (64 to 96 km). Long-range: Typically 500 to 1000 (800 to 1600 km).

Payload: 8 total, four per wing.

Note: Medium-range missiles are more available than long-range (the latter are expensive; 1D6x10,000 credits each vs 2D6x1000 for medium-range).

4. **Concealed Mini-Missiles (16):** An additional eight mini-missiles can be attached under each wing. These weapons are the primary armament of the fighter for air-to-air combat and anti-missile defense.

Primary Purpose: Anti-Aircraft.

Secondary Purpose: Defense.

Missile Type: Any mini-missile can be used, but Naruni Enterprises recommends its K-HEX missiles.

Mega-Damage: Varies with missile type (5D6 to 1D6x10 depending on type).

Rate of Fire: One at a time or in volleys of two or four.

Range: One mile.

Payload: 16 mini-missiles; 8 under each wing.

5. **Sensors & Features of Note:** The Star Dragon is equipped with advanced FTL-age sensors which are the most sophisticated available on Rifts Earth. They provide a bonus of +10% to the Read Sensory Equipment skill (also see #6 for bonuses). The sensor package includes advanced radar (can simultaneously track 144 targets, 200 mile/320 km range), radiation, thermographic, motion and long-range optics equal to the multi-optics helmet (passive nightvision, thermal-imaging, ultraviolet, etc., range of one mile/1.6 km), full radio transmission and reception with radio scrambler (100 mile/160 km range), laser communications (1000 mile/1600 km range), and laser targeting (120 mile/192 km range). Additionally, there is an advanced combat computer that can recognize and identify up to 3000 different targets with an 89% level of accuracy. (For outer space, the craft is also equipped with a gravity-wave sensor which can detect ships as far away as 200,000 miles/320,000 km; doesn't operate in atmosphere; and a system that detects ships traveling at FTL up to 10 light years away.)

6. **Combat Performance (Bonuses):** The Star Dragon is one of the most agile and maneuverable fighter space/aircraft there is. Pilots who benefit from specialized training receive the following bonuses: +2 on initiative, +3 to strike (laser targeting), +5 to dodge, automatic dodge in space, and +4 to dog-fighting rolls and special maneuvers. No bonuses or penalties to piloting skill with the special training; untrained pilots receive none of the bonuses above and suffer a penalty of -25% to all piloting and dog-fighting checks. **Note:** These bonuses are in addition to those gained from Jet Fighter Combat, O.C.C. bonuses, etc.

NE-MD1000

Wrath of God Destroyer

The design for the Wrath of God Destroyer is believed to pre-date Naruni Enterprises by several centuries. Exactly how this technology came into the Naruni's hands is unknown, but it is most certainly alien in origin. The company has only produced around one thousand of these feared weapons of mass destruction, and hundreds of worlds throughout the Three Galaxies have outlawed them.

A Wrath of God Destroyer is one of the most massive single-man weapon systems ever created for air and ground combat. Although larger vehicles exist, there are few more powerful. There is a catch. The Wrath of God Destroyer uses a unique method of control, within its pilot's chamber are millions of neural electric connectors that are designed to interface with the pilot. When a sentient being first enters the pilot's chamber, these connectors enter the skin of the pilot, ripping through flesh and burrowing themselves into the neural pathways of the pilot. They slice and rend the body, making all the connections required, while other equipment dissects the pilot's internal organs and subverts his internal systems to the machine's control. The pilot becomes a permanent part of the Destroyer as the mind of a killing machine that is over a city block long and bristling with weapons. However, the pilot is not in complete control, the machine is, the pilot is just used as a sort of computer bank and navigation system for the machine's A.I. Once inserted, the pilot is no longer a man, but a living component of a larger machine that helps it make subjective decisions and act on "hunches and gut instincts." It is the man that gives the machine its drive and its desire to exact revenge. It is the man that helps the Destroyer to know who its new enemies are, where to find them and how to destroy them.

Physically, the Wrath of God Destroyer looks like a large warship, with a flat bottom and no visible means of propulsion. In truth the machine is filled with Contra-Gravity generators that enable it to travel at good speeds and engage enemies both in the air or on the ground. The upper hull of the Destroyer is covered in weapon systems, while the lower hull is engulfed in a plasma field to prevent armed forces from trying to scale or board it from the ground or the bottom of the vessel. A pinpoint force field system moves to protect the parts of the vessel under heaviest attack and covers as much as half the vessel at any given time. Shields move and adjust as needed. (**Note:** Naruni Enterprises has never been able to miniaturize or to successfully replicate the massive force field defense mechanism found on the Wrath of God.) Many believe that the force field, like many other systems on the Destroyer, must be regulated by a sentient mind, thus they are useless in a conventional vehicle. The Wrath of God carries no live troops, just weapons and missiles. The machine will track down and destroy each and every "enemy" recognized by the once human pilot, including all members of the opposing army, the civilians of the opposing country, any personal enemies of the pilot, and even the people who insulted or provoked the pilot. The machine is very exacting, and all perceived enemies are exterminated.

Naruni Enterprises rarely sells the Wrath of God Destroyer to anyone in the Three Galaxies for fear of the possible political and military repercussions, but it does, sometimes, offer them to people in out of the way locations. Four are rumored to be available to buyers in North America, provided the price can be met. So far, no kingdoms are known to have purchased any. So far, there seem to be no takers (or, perhaps, anyone who can afford one), but sooner or later, some will "buy" one (and Naruni Enterprises does not actually expect to be paid in full if the buyer can pay two-thirds of the asking price up-front and plans to use it against the CS or Northern Gun). It is said that it takes several decades of painstaking construction to build one, which adds to the rarity of the horrid combat machine.

Model Type: NE-MD1000 Wrath of God Destroyer.

Class: Cybernetic All-Terrain Assault Battleship.

Crew: One.

M.D.C. by Location:

Bow Ram Prow – 5,000

Tail Impact Barrier – 5,000

Primary Particle Beam Cannons (3, one for each section) – 800 each

* Secondary Laser Beam Cannons (9, three to each section) – 600 each

* Mini-Missile Launchers (3; one for each section) – 100 each

* Medium-Range Missile Launcher (1; mid/primary section) – 200

* Communication Arrays (3, one per section) – 300 each

* Forward Spotlights (4) – 50 each

* Rear Spotlights (4) – 50 each

* Sensor Clusters (6, scattered across the hull) – 120 each

** Main Body of the Forward Section – 10,000

** Main Body of the Primary Section – 15,000

** Main Body of the Rear Section – 7,000

*** Pinpoint Force Field – 4,000

* A single asterisk indicates small or otherwise difficult targets to hit. A “Called Shot” is needed to hit it and the shooter is -2 to strike. Destroying all of the Sensor Clusters will blind the Wrath of God Destroyer, at least temporarily.

** Depleting the M.D.C. of the main body of each section will destroy that particular section and all weapon systems and sensors contained within it. Depleting the 15,000 points of the Primary Section deactivates the heart of the Wrath of God Destroyer, shutting down all its weapon systems, communications, sensors, Contra-Gravity systems and the force field, but unless all three sections are destroyed the vessel will continue to repair itself. Once the Primary Section has at least 1000 M.D.C., all of its functions return to normal.

*** If the M.D.C. of the force field is depleted, it overloads and cannot be reactivated again for 4 hours. As long as the force field’s M.D.C. has not been overloaded, it regenerates lost M.D.C. at the rate of one point per melee round (that’s four M.D.C. points per minute). An overloaded force field can be activated at full strength (all M.D.C.) after the 4 hour delay has expired. The secondary force field only activates after the primary force field has been overloaded, and only one can be up at a time.

Speed:

Ground Speed: The Destroyer can not drive on land, but does not need to, due to the Contra-Gravity field.

Flying: Contra-Gravity system allows for flight at up to Mach One (670 mph/1072 km) or up to Mach 16 (10,720 mph/17,152 km) in space. The contra-gravity system enables the Wrath of God Destroyer to hover in stationary position at any altitude desired, but it usually stays close to the ground, under 2000 feet (610 m).

Maximum Altitude: Unlimited. The Contra-Gravity system allows the ship to escape a planet’s atmosphere and fly out of orbit.

Underwater: Maximum speed of 100 mph (160 km/86 knots) using the Contra-Gravity system.

Maximum Depth Tolerance: Unlimited. The hull of the Wrath of God Destroyer cannot be crushed by ocean depths.

Maximum Range: Unlimited. The Contra-Gravity system does not overheat.

Statistical Data:

Height: 104 feet (32 m).

Width: 160 feet (48.7 m).

Length: 312 feet (95 m).

Weight: Unknown!

Cargo: None.

Power System: Anti-Matter/Matter, average life is unknown (centuries?).

Retail Market Value: “Sold” for 3.2 billion credits, available on a payment plan and well worth the price.

Weapon Systems:

Note: Under “Rate of Fire” the number of times each weapon can be used/fired per melee round is listed. The Destroyer can use each of the weapons listed every melee round, adding up to multiple attacks per round.

1. **Primary Particle Beam Cannons (3):** Three huge particle beam cannons are mounted in each section of the Destroyer, like some great pre-Rifts battleship, but all of these guns can swivel independently to engage their own targets.

Primary Purpose: Assault.

Secondary Purpose: Defense.

Mega-Damage: 2D4x10+12 M.D. per particle beam blast.

Rate of Fire: Each of the three particle beam cannons may fire twice per melee round.

Range: 4,000 feet (1219 m).

Payload: Effectively unlimited.

Bonus: +2 to strike.

2. **High-Powered Laser Cannons (9):** Each section of the Destroyer has three laser cannons that independently select and destroy their targets.

Primary Purpose: Defense.

Secondary Purpose: Assault.

Mega-Damage: 1D6x10 M.D. per single laser beam or 3D6x10 per simultaneous triple cannon blast at the same target (counts as one attack for each cannon).

Rate of Fire: Each of the nine laser cannons may fire four times per melee round.

Range: 6,000 feet (1829 m).

Payload: Effectively unlimited.

Bonus: +4 to strike.

3. **Medium-Range Missile Launcher (1):** A medium-range missile launcher is located in the mid-section.

Primary Purpose: Anti-Aircraft and Anti-Fortifications.

Secondary Purpose: Assault and Defense.

Missile Type: Any medium-range missile can be used.

Mega-Damage: Varies with the missile type, but typically 2D6x10 or 3D6x10 (not nuclear).

Rate of Fire: One at a time or in volleys of two or four. The launcher can fire twice per melee round.

Range: Medium-Range: 40-60 miles (64 to 96 km). Long-Range:

Typically 500 to 1000 (880 to 1600 km).

Payload: 16 total.

Note: Medium-range missiles are more available than long-range (the latter are expensive; 1D6x10,000 credits each vs 2D6x1000 for medium-range).

4. Mini-Missile Launchers (3): Each launch turret can rotate 360 degrees and is available for assault or defense.

Primary Purpose: Anti-Aircraft.

Secondary Purpose: Defense and Assault.

Missile Type: Any mini-missile can be used.

Mega-Damage: Varies with missile type. Naruni Enterprises recommends its K-HEX High Explosive (1D4x10 M.D.) or its Plasma missiles (1D6x10 M.D.).

Rate of Fire: One at a time or in volleys of two, four or six. Each launcher can fire two times per melee round.

Range: One mile.

Payload: 216 total: 72 mini-missiles in each launcher.

5. Bow Ram Prow & Tail Impact Barrier: One of the Destroyer's trademark attacks is to ram into other large vessels and fortifications as well as plow through the ranks of infantry soldiers, power armor and tanks.

Primary Purpose: Close Combat.

Secondary Purpose: Assault and Self-Defense.

Mega-Damage:

1D6x100 M.D. to targets 100 feet (30.5 m) or larger.

1D4x100 M.D. to targets 50-99 feet (15.2 to 30 m).

4D6x10 M.D. to targets 25-49 feet (7.6 to 14.9 m).

1D6x10 M.D. to each target less than 25 feet (7.6 m) that is stuck by the ramming or plowing attack.

Note: The target of any successful ram or plow attack is automatically knocked down, losing the initiative and two melee attacks/actions in addition to damage.

Rate of Fire: A ram/plow attack can only be done every other melee round and counts as half of the Destroyer's attacks for that melee round.

Range: Immediate proximity.

Bonuses: +2 to strike with the Bow Ram Prow, +1 to strike with the Tail Impact Barrier.

6. Anti-Boarding Plasma Field: Once moving, the bottom hull generates a fiery plasma field capable of inflicting serious damage to anything that touches it.

Primary Purpose: Self-Defense.

Secondary Purpose: Intimidation.

Mega-Damage: The plasma field inflicts 6D6 M.D. to anything that touches it and has a 01-60% chance of knocking the opponent off his feet due to the backblast (the victim loses the initiative and one melee attack/action for that round). Plus, anything flammable that comes in contact with the plasma field burns, including S.D.C. bullets and weapons.

Rate of Fire: Continuously on when in motion.

Range: Ten to twenty feet (3 to 6.1 m) from the surface of the Wrath of God Destroyer's underside.

Payload: Effectively unlimited.

7. Drones: The typical Destroyer comes with a complement of Combat Drones that include: Ten NE-010 Destructo-Drones

(little more than an intelligent missile), ten NE-020 Combat Drones (the NE-010 and 020 both originally appeared in Rifts Mercenaries), two NE-030 Spy Drones, five NE-040 Point Defense Drones (described in the robot section of this book, it is not so much a combat pod as it is a remote sensor module and detection device) and four NE-A420 Ground Attack Drones (aerial robot fighter pods designed to engage ground troops; described in the robot section of this book).

8. Nano-Regeneration: The Wrath of God Destroyer is virtually swarming with nano-repair bots internally. These microscopic robots repair damage to the Destroyer at a phenomenal rate. When the regenerative process is active (i.e.: anytime the Destroyer is damaged), 1D4x10 M.D.C. is repaired per minute. The regained M.D.C. is only to one location at a time and any damage is reversed as that location is repaired, bringing sensors, communications, and weapons back online, etc. In a pinch, this regenerative process will bring the Destroyer back from the brink of destruction, if given sufficient time. In the Three Galaxies, people know to blast the vessel to atoms, just to be safe.

9. Sensor Systems of Note: The Destroyer has some of the best sensory equipment available in a robot vehicle. In addition to all the standard robot accessories, the Wrath of God has the following sensors:

1. Thermo-Imager: A special optical heat sensor that allows the infrared radiation of warm objects to be converted into a visible image. Enables the Destroyer to see in the dark, in shadows, and through smoke, as well as see most invisible beings (only the spell, Invisibility: Superior can defeat this sensor system). Range: 5000 feet (1524 m).

2. Infrared and Ultraviolet Optics: This optical system projects a beam of infrared light that is invisible to the normal eye. The infrared beam enables the Destroyer to see in the dark and to see other infrared beams. The ultraviolet system enables the Destroyer to see into the ultraviolet spectrum of light and is mostly used to detect the light beams of ultraviolet detection systems. Note: The infrared light beam can be seen by anybody who also has infrared optics, and the beam can be traced back to its source. Smoke impairs the infrared beam, making it impossible to see.

3. Infrared Searchlights: The Wrath of God Destroyer has eight spotlights that also serve as infrared searchlights. The lights can be used to scan an area at night using the invisible light to avoid detection, or they can illuminate the area in visible light. Only somebody who can also see infrared light will see the infrared beam. Range: 2000 feet (610 m).

4. Enhanced Radar: Can identify and simultaneously track up to 196 different targets. Range: 100 miles (160 km).

5. Gravitic Sonar: In addition to the upgraded radar, the machine has an advanced system that uses gravity waves as a form of "sonar." This system can electronically map even the insides of structures (and any occupants). Combined with the enhanced thermo-imager, the sensor system can detect invisible targets, find people hiding inside buildings or vehicles, and even detect traps and hidden troops. The sensor system cannot penetrate force or phase fields, however. Range: 2000 feet (610 m).

10. Combat Bonuses: The old combat bonuses and attacks per melee of the pilot are irrelevant once he becomes part of the vessel, only the pilot's old skills remain, now used by the Wrath

of God Destroyer in addition to all of the Destroyer's preprogrammed skills. **Note:** Each weapon indicates bonuses for that item, but the Destroyer also gets the following: +2 on initiative, +2 to strike, parrying is not applicable, +2 to dodge, and +4 to roll with impact. The destroyer never disarms or pulls punches, and the melee actions/attacks are as listed under each weapon above.

11. Invulnerabilities of Note: The Destroyer is immune to Horror Factor and though it has a human brain as one of its key components, all forms of psionics and magic involving mind control have no effect. The exceptions are Telepathy (can receive Telepathic communication if it is welcomed, but can also close itself to Telepathy if unwanted or being probed; effectively Mind Block without I.S.P. cost – basically the A.I. takes over) and all forms of Telemechanics (but only one individual and isolated weapon system, sensor, or mechanical component can be affected at a time, never the entire vessel nor the A.I.). Furthermore, the Destroyer is +6 to save vs illusion and cannot be mentally possessed. Remember, the once human brain incorporated into the Wrath of God is part of a complex, alien, dual command/control system that provides the raw drive and lust for destruction of the Destroyer. Though it may control as much as one third of the combat and operating systems at any one time, the master artificial intelligence (A.I.) controls the other two-thirds and can override the human component at any time. Furthermore, the human pilot (or what's left of him) is more machine than man, and no longer has any human frailties (does not need to eat, drink, breathe or sleep as we know it, the machine provides for everything). Thus, the pilot is just another component of the massive Wrath of God Destroyer.

12. Preprogrammed Skills of Note: These skills are in addition to any the pilot may have had. Speaks: American, Dragonese, French, Japanese, Spanish, Splugorth, and Wolfen, all at 98%. Is also understandable in 30 other languages, like Dutch, Faerie, German, Italian, Polish, Portuguese, Russian etc. at 45%; most are obsolete and forgotten languages.

Pre-programmed for combat, tactics and strategy. Combat program includes the identification of all known military units from the Phase World dimension, plus Coalition, Free Quebec and Splugorth troops, robots and vehicles, common animal and D-Bee life forms, common 'bots, armor, weapons and vehicles, and combat tactics in response to them. Much of this is new programming for Rifts Earth. A complete understanding of demolitions and demolitions disposal at 90% each.

Other skills include: All Communications skills at 94%, Detect Ambush 60%, Detect Concealment 60%, Intelligence 90%, Interrogation 85%, Tracking 60%, NBC Warfare 78%, Ship to Ship Combat 90%, all Navigation skills at 94%, Read Sensory Equipment 94%, Weapon Systems 90%, Basic and Advanced Math at 98%, Biology 94%, Chemistry 90%, Computer Operation 90%, Computer Programming 85% and Cyberjacking 90%.

G.M. Note: The Wrath of God Destroyer is not meant to be available to player characters, it is a plot hook and story device to move your characters on to greater heroism. If a player character became the Wrath of God Destroyer, the effects would be disastrous. Remember that the Destroyer is bent on killing (not hurting or maiming) everyone that has ever crossed the character. If any other player character had crossed the pilot, even once, the Destroyer would hunt him down and murder him without any re-

morse or compassion. That is just what the machine is, it's what it does, that is it's reason for being.

Naruni Attack Drones of the Destroyer

Reprinted from Rifts® Mercenaries for the reader's convenience. Written by C.J. Carella.

NE-010 Destructo-Drone

This is a flying robot drone that is little more than an intelligent missile! The drone is fish-shaped, using its tail like a rudder for quick moves in the air. It has a rudimentary computer and navigation system, and basic sensor capabilities. It attacks by flying full-speed at the target and detonating its payload. It has a light laser, mostly for anti-missile/self-defense purposes, but it will shoot the laser at the intended target (or secondary targets or defenders nearby) while in pursuit on its suicide run. The Destructo-Drone can be programmed to accept launch orders from an operator, a Combat Drone, or a Combat Pod. By itself, it can be easily fooled; it is best used as a secondary weapon.

Unlike a normal missile, the drone's slower speed allows it to correct its course, avoid obstacles, dodge enemy attacks, and turn around if it misses its target on the first pass. Likewise, it can follow targets that take evasive action. If it loses its target, the smart bomb can stop, land, and wait until "the" target reappears, or another programmed target comes on the scene!

The explosive charge in the drone is as potent as most long-range missiles. The Destructo-Drones don't have nuclear engines. Instead they have a limited power supply that can carry them about 2400 miles (3840 km), and also have a power cord that allows the drones to recharge their batteries off any nuclear engine!

These incredible smart bombs are often dispatched with a Spy or Combat Drone and can recharge off them, if necessary. Otherwise, once activated, the drone's power will run out in about 24 hours of continual flight (72 hours if it stops and remains dormant most of the time) or until it finds its target and explodes, whichever comes first. One great tactic is to leave a half dozen or more Destructo-Drones behind retreating troops or as an ambush, so that the missiles can attack advancing enemy 'bots, armored vehicles or low flying aircraft and power armor. The drone is most effective against armored ground vehicles, 'bots and power armor.

Model Type: NE-010 Smart Bomb.

Class: Naruni Infantry Drone Missile.

Crew: None.

Speed: Hover stationary, cruising speed 200 mph (320 km) and up to 400 mph (640 km) at full missile speed. Maximum hover height is 5000 feet (1524 m).

Effective Range: 2400 miles (3840 km) without recharging; battery life is 24 to 72 hours depending on activity of the missile.

Size: 2 feet (0.6 m) in diameter, 7 feet (2.1 m) long.

Weight: 500 lbs (225 kg).

M.D.C. by Location:

Small Assault Laser (1) – 15

Lower Hover Jets (3) – 10 each

Main Rear Rocket Jet (1) – 30

Main Body – 70

Mega-Damage: Small Light Laser: 2D6 M.D. Explosive Charge: 3D6x10 M.D. to a 15 foot (4.6 m) area.

Rate of Fire: Four laser blasts per melee.

Effective Range: Laser: 2000 feet (610 m).

Payload: 100 laser blasts.

Robot Defense System: Combat program enables it to recognize, locate and identify targets 89%, hide and prowls at 48%, land navigation 89%, detect ambush 50%, detect concealment 48%, and can recognize 1000 different targets.

Bonuses: +2 on initiative, +6 to strike, +8 to dodge, four attacks per melee (laser; or one impact attack destroying the drone).

Sensors & Optics: Infrared, passive night-sight and laser targeting. Motion detector and radar (can track 24 different targets, one mile/1.6 km range). Full radio transmission and reception, plus radio scrambler.

Cost: 150,000 credits (double on the Black Market; rare). This may seem expensive for a device that can only be used once, but these drones can be incredibly effective!

NE-020 Combat Drone

The **NE-020** is a Combat Drone that has a heavy laser cannon and a mini-missile launcher with hover jet propulsion and robot response system. The robot "brain" simulates the abilities of a human gunner, while the hover system and small size allow the robot drone to maneuver better than an infantryman or biped robot. Like most robots, the drones lack imagination and initiative. They blindly follow orders which can sometimes be as much a curse as a blessing. Combat Drones are especially useful for groups that have limited manpower and for hazardous missions.

Combat Drones can also be directed through a remote control computer. The computer screen shows the drone's controller whatever the drone is sensing/experiencing so that he can react accordingly — the sensation is similar to playing a video game. A more advanced Virtual Reality System can also be used, giving the wearer the illusion that he is actually the drone! The VR system costs half a million credits — the remote control and simple robot brain are part of the standard package.

Model Type: NE-020 Combat Platform.

Class: Naruni Infantry Drone Robot.

Crew: None.

Speed: Hover stationary or up to 60 mph (96 km). Maximum hover height 600 feet (182 m).

Size: The main body is one foot (0.3 m) thick, 3 feet (0.9 m) wide and 6 feet, 6 inches (1.9 m) long.

Weight: 650 lbs (292.5 kg).

Power System: Nuclear.

M.D.C. by Location:

Sensor Antenna (3) — 20 each

Mini-Missile Launcher — 35

Laser Cannon — 120

Lower Hover Jets — 40

Main Body — 100

Mega-Damage: Laser Cannon: 5D6 M.D. per blast.

Mini-Missiles: Damage varies with missile type.

Rate of Fire: Six attacks per melee round; any weapon combination.

Effective Range: Laser Cannon: 6000 feet (1829 m), mini-missiles vary with type; about one mile (1.6 km).

Payload: Effectively Unlimited for the laser. Mini-missiles: Eight; any type.

Robot Defense System: Combat programs enable it to relocate to a better position, hide and take evasive action, perform rudimentary strategy and tactics: Detect Ambush 80%, Detect Concealment 68%, Land Navigation 80%, Intelligence 80%, Prowl 60%, and can recognize 1000 different targets.

Bonuses: +1 on initiative, +2 to strike and parry, +4 to dodge, impervious to gas, poison, mind control, Horror Factor, possession, and illusions.

Sensors & Optics: Full range optics equal to a multi-optics helmet, including thermo-imager, infrared, ultraviolet, passive night-sight, telescopic, and laser targeting. Motion detector, heat sensor, radiation sensor, radar detector, radar (can track 48 different targets, one mile/1.6 km range), enhanced hearing, full radio transmission and reception, radio scrambler.

Cost: Two million credits (double on the Black Market; rare).

NE-030 Spy Drone

A drone used for reconnaissance and covert operations. It is equipped with an advanced stealth configuration and has a camouflage fiber-optic exterior similar to the variable armor. It also has a sophisticated sensor system and a good deal of information processing capabilities. Its hover system has special sound suppressors that make it effectively noiseless (prowl 89%). The Spy Drone can be linked with up to four other drones, such as the Combat Drone or Destructo-Drone, which it can control. In a combat situation, the Spy Drone will try to remain hidden while it directs the attacks of the others.

Model Type: NE-030 Reconnaissance Drone.

Class: Naruni Infantry Scout Drone.

Crew: None.

Speed: Hover in a stationary position or up to 150 mph (240 km). Maximum hover height is 1000 feet (305 m).

Size: 3 feet (0.9 m) tall, 3 feet (0.9 m) wide and 7 feet (2.1 m) long.

Weight: 800 lbs (360 kg).

Power System: Nuclear.

M.D.C. by Location:

Sensor Array (1) — 50

Communications Array (1) — 50

Laser Turret (1) — 50

Retractable Arms (2) — 25 each

Lower Hover Jets (3) — 30 each

Main Body — 125

Mega-Damage: Laser Turret: A light double laser: 4D6 per double blast; can rotate 360 degrees.

Rate of Fire: Seven per melee round.

Effective Range: 2000 feet (610 m).

Payload: Effectively unlimited.

Special Features:

1. A pair of small, thin, retractable arms that enable the drone to pickup, retrieve and carry objects. P.S. 18, they are not designed for combat but can inflict 1D4 M.D. from punches or fire handguns.

2. Camouflage fiber-optic exterior similar to the variable armor.

3. Sound suppression hover jets.

Robot Defense System: Combat and spy programs enable it to relocate to a better position, hide, set ambushes, and take evasive action. It can also perform simple strategy and tactics, Detect Ambush 92%, Detect Concealment 89%, Land Navigation 80%, Intelligence 89%, Prowl 89%, and can recognize 10,000 different targets.

Bonuses: +2 on initiative, +3 to strike and parry, +5 to dodge, impervious to gas, poison, mind control, magic illusions and Horror Factor (unless controlled by a human operator).

Sensors & Optics: Full range optics equal to a multi-optics helmet, including thermo-imager, infrared, ultraviolet, passive night-sight, telescopic, and laser targeting. Motion detector, heat sensor, radiation sensor, radar detector, radar (can track 48 different targets, one mile range), enhanced hearing, full radio transmission and reception, radio scrambler.

Cost: Four million credits (triple from the Black Market; rare).

Land Mines

NE Basic Land Mines

AIM-1 Anti-Personnel Mine

The AIM-1 Anti-Personnel Mine is probably the most simple, unsophisticated weapon produced by Naruni Enterprises. It is similar to the average land mine used by countless cultures across the Megaverse. The only difference is that this NE version uses a K-HEX advanced explosive charge. AIM-1 mines are detonated either by snapping a trip wire or by 30 lbs (13.5 kg) of pressure.

Weight: 3 lbs (1.4 kg).

Mega-Damage: 6D6 M.D. to a 20 foot (6.1 m) area.

Cost: 400 credits.

NE-MAT-3 Anti-Matter Anti-Tank Mine

A magnetic explosive that comes as a disk-shaped unit that can be buried a few inches under the surface (detonates when at least three tons rolls over it) or can be timer set (5-180 second timer). To use the timer, set the time, slap it onto the tank or the metallic target and get out of the way. May be used for sabotaging armored vehicles, robots, bridges, railroads, ammo dumps, and towers, and penetrating bunkers and fortifications. These devices are devastating, highly effective and lethal to most armored vehicles. They are extremely popular in the Three Galaxies, especially among mercenary forces and with the Free World Council, and are being made available on Rifts Earth for

the very first time! **Note:** Due to the internal magnetic containment field these mines have a high metallic composition (45% metal) and are relatively easy to detect (are instantly detected by sensors capable of detecting magnetic fields).

Type One: Light Anti-Tank Mine

Weight: 15 lbs (6.8 kg).

Mega-Damage: 3D4x10 M.D.

Blast Radius: 100 feet (30.5 m).

Cost: 15,000 credits.

Type Two: Heavy Anti-Tank Mine

Weight: 25 lbs (11.3 kg).

Mega-Damage: 1D4x100 M.D.

Blast Radius: 500 feet (152 m).

Cost: 80,000 credits.

NE-APM Anti-Personnel Mobile Mine

A toy-like mobile mine with four legs. The mine is designed to overwhelm ground troops by literally overrunning them and detonating in their midst. The simple devices are activated, pointed in the right direction and unleashed. The mines run into the enemy camp or company and explode. They are extremely small and simple, basically a black basketball with legs. Explode when five or more targets are within its blast radius of 12 feet (3.6 m). Typically unleashed en masse, by the hundreds or thousands.

Weight: 20 lbs (9 kg).

Speed: 30 mph (48 km).

M.D.C. of the Mine: 15 M.D.C. (can be shot and blown up before it reaches its target).

Mega-Damage: 6D6 to a 12 foot (3.6 m) blast radius.

Combat Programming: Run, detonate and recognize friendlies.

Bonuses: +1 on initiative, +1 to dodge, one self-destruct attack.

Sensors & Optics: Basic.

Cost: 17,000 credits (double on the Black Market; rare), 10% discount when purchased by the dozen.

Smart Bombs & Mobile Mines

Thunderstorm

Mobile Land Mines (MLM)

The Thunderstorm MLMs are small, sophisticated weapons built on four different chassis. The first is a hovercraft-like weapon equipped with hover jets to travel quickly over land and water. The second is a small torpedo-like affair, used underwater. The third is more or less a missile, with VTOL capabilities. The fourth is more like a conventional land mine planted in the ground, but unlike a normal land mine, this MLM tunnels underground to reach its designated target, then explodes. Each of the Thunderstorms has its own ideal environment and mission profile, but all of the Mobile Land Mines (MLMs) are highly effective. When dispatched in groups the mines coordinate their attacks via short-range radio signals so they each attack a different target or concentrate on one or two primary targets, whichever they've been programmed to do. All the Thunderstorms, except for the Sneaker, dart to within a foot (0.3 m) of their designated target before they explode. If they miss, a Thunderstorm will turn back and continue pursuing the target until either it hits or the Thunderstorm mine is destroyed. If the target should manage to escape (teleports away, flies out of range, etc.) the Mobile Land Mine will land, hide itself once again, and wait for a new target to present itself. Only the Sneaker MLM operates in a different fashion. The Sneaker maneuvers itself under its designated target, then explodes, hopefully taking the target with it.

Fast and controlled by a simple artificial intelligence, the Thunderstorm MLMs can be programmed and sent out as roving land mines or missiles to hunt particular targets, lying in wait until something that fits their target protocol comes into sight. The smart bomb will then either wait until the target comes within its blast range or fly out and strike it before the people know what hit them. The strategic use of Thunderstorm MLMs usually involves being launched or dropped into a particular area where the mines hide at what appear to be areas of traffic/travel (roads, paths, clearings, etc.). The Thunderstorm is a semi-intelligent, roving land mine, able to pick up and reposition itself wherever it's most effective. When its scanners pick up on a target it strikes, but first radios the other nearby MLMs that it is doing so, to prevent them from attacking too and wasting themselves. If traffic occurs at a different area nearby, the MLMs move closer to that area, hide again, and wait until a designated target reveals itself. Of course, as a smart bomb, it will NOT detonate even if

stepped on by troops, people, or vehicles designated as friendly or which simply are not a designated enemy. Its only valid targets are those pre-programmed into its memory banks. When out of energy an MLM will just sit dormant and wait until an enemy comes within range. However, Thunderstorm MLMs seldom expend so much energy that the units become immobile. A built-in solar recharger provides the units enough energy for a five minute pursuit after just 6 hours of sunlight.

Thunderstorms also employ a variation of the Naruni Enterprises Variable Camouflage material that can change colors to match the general environment. When added to the MLMs stealth programming, it makes the smart bombs incredibly hard to detect before they strike. The color change takes 1D4 melees (15 to 60 seconds) and makes the MLM the exact same color as the predominant one in the area.

(Note: The current marketing plan, a little insider news to all our good customers on Rifts Earth, is to sell as many of these systems to the ex-forces of Tolkeen as possible, in hopes that they can set up an area of denial against the Coalition, and perhaps one day regain their lost kingdom. As such, Naruni Enterprises is offering a 20% discount on all Thunderstorm MLM systems to anyone who can prove they are members of the Tolkeen resistance force, a Retribution Squad, Chi-Town terrorist group or ex-soldier with a hatred of the CS or its armed forces.)

Costs are triple on the Black Market and MLMs are super-scarce from any source other than Naruni Enterprises.

NE-TA03 "Streaker"

Thunderstorm MLM

The Streaker MLM is designed along the lines of the NE-010 Destructo-Drone or UAV. It is sleek, aerodynamic and deadly. The standard programming of the Streaker is to land at a designated drop point and use its camouflage system to hide. When a target enters sensor range, the Streaker is to rise up and rocket toward the target at a speed of Mach Two. It may strike from several hundred feet in the sky or low to the surface (about 12-20 feet/3.6 to 6.1 m). However, the Streaker is actually designed to engage in ground to air combat, streaking into the sky to hit aircraft, Wing Boards, power armor, winged creatures, magically endowed flying people, and other aerial targets.

Primary Purpose: Ground to Air Attacks/Anti-Aircraft.

Secondary Purpose: Ground to Ground Attacks/Anti-Armor and Anti-Personnel.

Weight: 88 lbs (40 kg).

Size: Approximately 3 feet (1 m) long.

Main Body M.D.C.: 25

Mega-Damage: 2D4x10 M.D. to a 12 foot (3.6 m) radius. The MLM is destroyed in the blast.

Range: 1000 miles (1600 km).

Speed: Cruising speed is 200 mph (320 km), but a final attack run is Mach Two (1340 mph/2144 km).

Attacks per Melee: Once engaged, the MLM will try to hit and detonate into its target. It has three melee attacks/actions per melee round, though the act of dodging uses up one attack. Will pursue an enemy target for up to five minutes.

Bonuses: +4 to strike, +3 to dodge and +5 to strike as a hidden land mine.

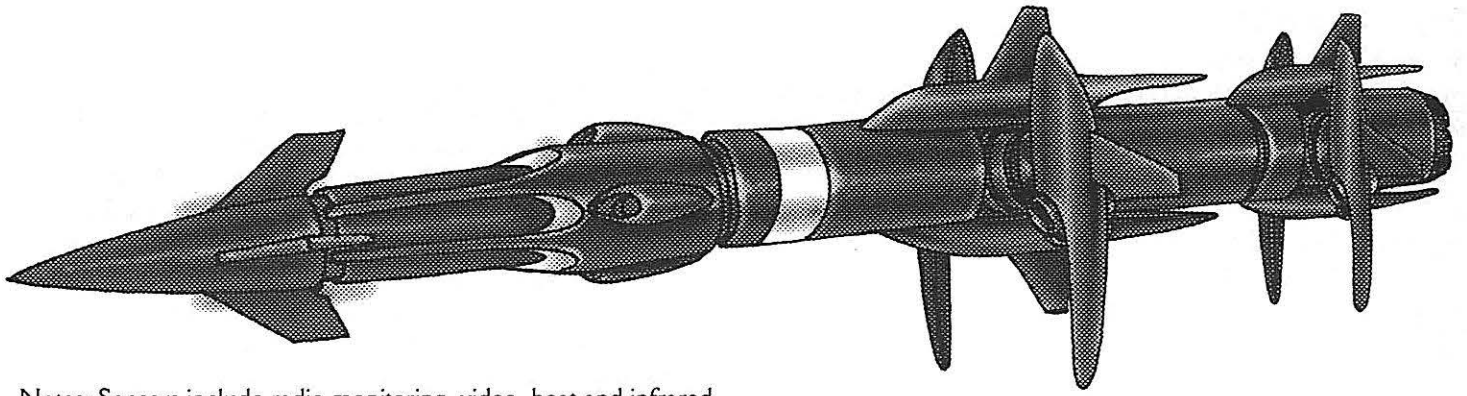

Notes: Sensors include radio monitoring, video, heat and infrared optics, as well as radar with a 10 mile (16 km) range.

Cost: 50,000 credits, including the handheld programming pad for the unit.

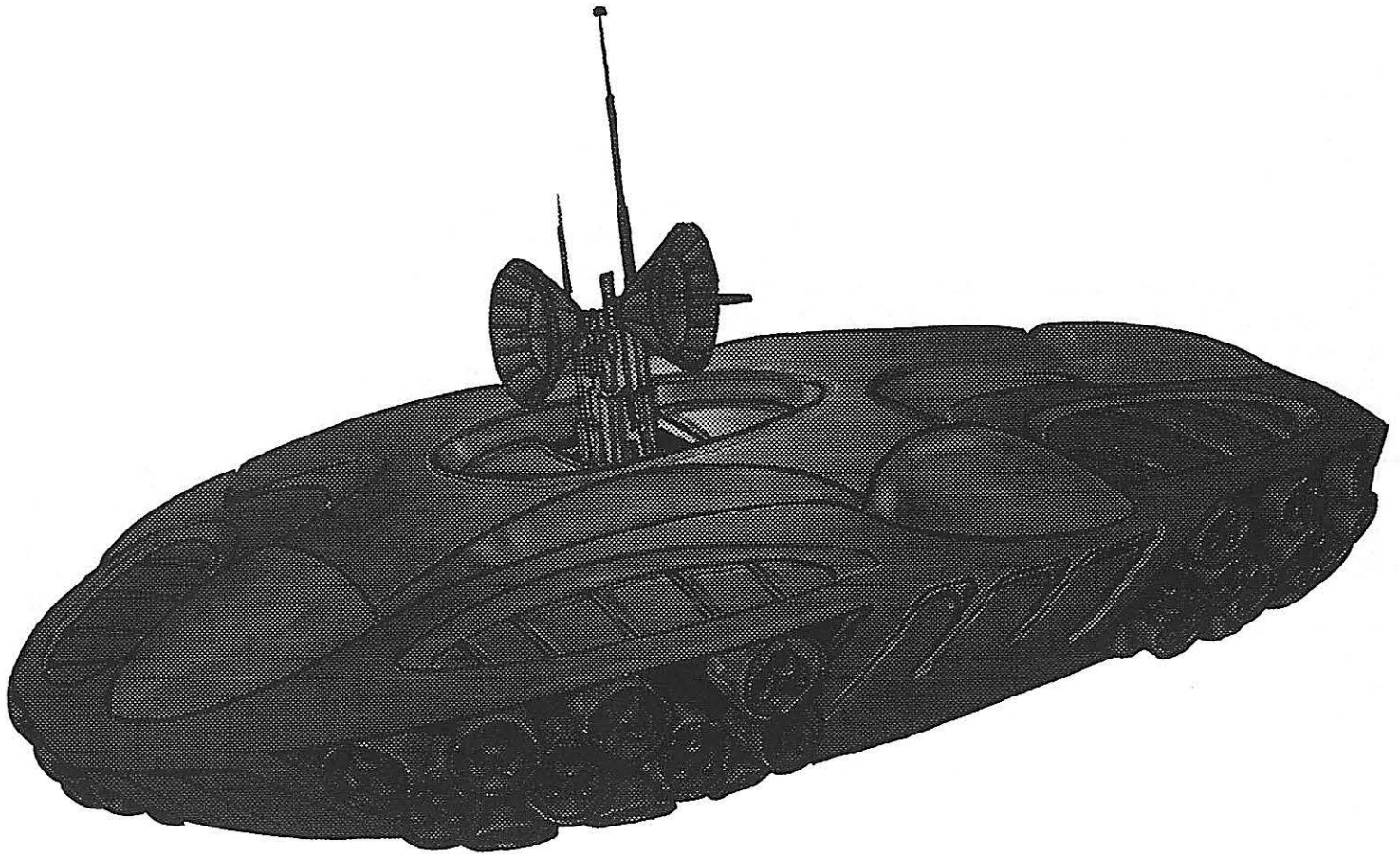

NE-TH05 "Land Skimmer" Thunderstorm MLM

The Land Skimmer is designed for maximum mobility and stealth, so it can only rise up to four feet (1.2 m) above the ground when flying toward its target. All the while hugging the ground to avoid radar and easy visual detection, and navigating around obstacles in its path until its target is found. While laying in wait, the Land Skimmer camouflages itself by shooting out powerful jets of air, covering itself in sand, loose dirt, leaves and debris. This increases the penalty to spot the Skimmer by -10% (for a total of -50% penalty against those trying to Detect Ambush or Detect Concealment by the Land Skimmer). This makes it an ideal weapon for the desert, grasslands or dry forests.

Primary Purpose: Anti-Armor.

Secondary Purpose: Anti-Personnel.

Weight: 100 lbs (45 kg).

Size: Approximately 3 feet (1 m) long.

Main Body M.D.C.: 25

Mega-Damage: 2D6x10 M.D. to a 20 foot (6.1 m) radius, and the MLM is destroyed in the blast.

Range: 500 miles (800 km).

Speed: 100 mph (160 km).

Attacks per Melee: Once engaged, the MLM will try to hit and detonate into its target. It has three melee attacks/actions per melee round, though the act of dodging uses up one attack. Will pursue an enemy target for up to five minutes.

Bonuses: +3 to strike, +2 to auto-dodge and +6 to strike as a hidden land mine.

Notes: Sensors include radio monitoring, video, heat and infra-red optics, as well as radar with a 5 mile (8 km) range.

Cost: 45,000 credits, and includes the hand-held programming pad for the Skimmer.

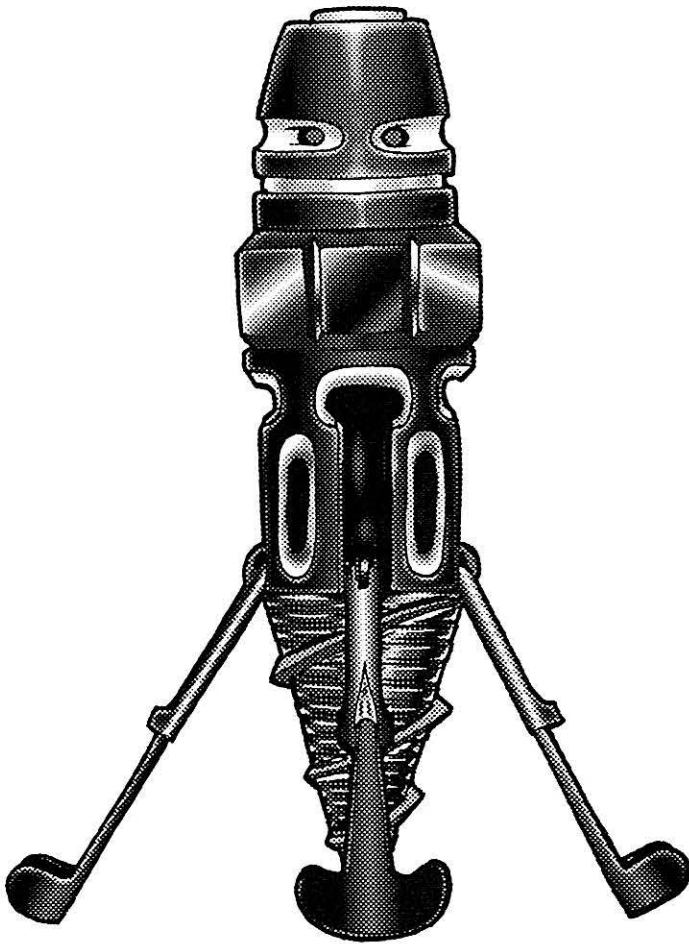

NE-TT07 "Sneaker" Thunderstorm MLM

Although the Sneaker is the slowest of the MLMs, its unusual method of attack makes it one of the most effective, even if it is limited to attacking other slow, land-based units. The Sneaker burrows its way quietly underground, 1-4 feet (0.3 to 1.2 m) under the surface. Unseen and undetectable by radar, the Sneaker is in the best position to strike at the enemy, especially an entrenched enemy. Only seismic sensors can detect the Sneaker when underground, and most (98%) troop formations don't use them. Ordinary eyesight and optics may spot the smart bomb when the MLM surfaces to recharge its solar energy cells, but even then the Sneaker is low profile (flat on the ground) and often partially concealed by debris or shadow, and hard to notice (only the solar collector cells need to be out in the sun).

Meanwhile, the Sneaker has its own seismic sensors to detect approaching ground troops, trucks and heavy vehicles. A periscope pops up above the surface of the ground to make a visual verification of the target and to check its surroundings and to make course corrections when tunneling. Note that the Sneaker

is so cleverly concealed that there is only a 01-02% chance that someone with amplified hearing might detect the MLM's approach/tunneling 1D6x10 seconds before it detonates (01-20% chance 1D6x10+40 seconds before detonation if the character is sensitive to vibration or linked to the element of Earth). The only time the Sneaker is truly vulnerable to attack or detection is when it is on the surface recharging its internal power supply.

Weight: 144 lbs (65 kg).

Size: 4 feet (1.2 m) long.

Main Body M.D.C.: 30

Mega-Damage: 2D6x10 M.D. to a 6 foot (1.8 m) radius, and the weapon is destroyed in the blast.

Range: Unlimited, although the MLM must surface to recharge its batteries every 24 hours.

Speed: Tunneling: Five mph (8 km).

Attacks per Melee: Only one. Unlike the other MLMs the Sneaker attacks via a direct underground detonation.

Bonuses: +5 to strike, +2 to dodge and +7 to strike as a land mine hidden underground.

Notes: Sensors include radio monitoring, video, heat and infra-red optics, as well as seismic with a 2 mile (3.2 km) range.

Cost: 90,000 credits, and includes the hand-held programming pad for the Sneaker.

NE-TU09 "Swimmer" Thunderstorm MLM

The Swimmer MLM operates much like an intelligent torpedo. It slowly patrols (about 20 mph/32 km) its designated waters or sits at the bottom waiting for a designated target to come into range. When a valid target is detected, the Swimmer kicks in its full speed and torpedoes toward its target, making course corrections as necessary. The only other times a Swimmer stops moving are to act as a floating mine or to recharge its internal power supply on the water's surface.

Weight: 122 lbs (55 kg).

Size: 4 feet (1.2 m) long.

Main Body M.D.C.: 30

Mega-Damage: 3D4x10 M.D. to a 10 foot (3 m) radius, and the MLM is destroyed in the blast.

Range: 500 miles (800 km), although the MLM must surface to recharge its batteries every ten hours.

Speed: Has a maximum underwater and surface speed of 300 mph (480 km/259 knots).

Attacks per Melee: Once engaged, the MLM will try to hit and detonate into its target. It has three melee attacks/actions per melee round, though the act of dodging uses up one attack. Will pursue an enemy target for up to five minutes.

Bonuses: +3 to strike, +2 to dodge and +4 to strike as a hidden sea mine floating in the water.

Notes: Sensors include radio monitoring, video, heat and infra-red optics, as well as radar/sonar with a 5 mile (8 km) range.

Cost: 45,000 credits, which includes the hand-held programming pad for the Swimmer.

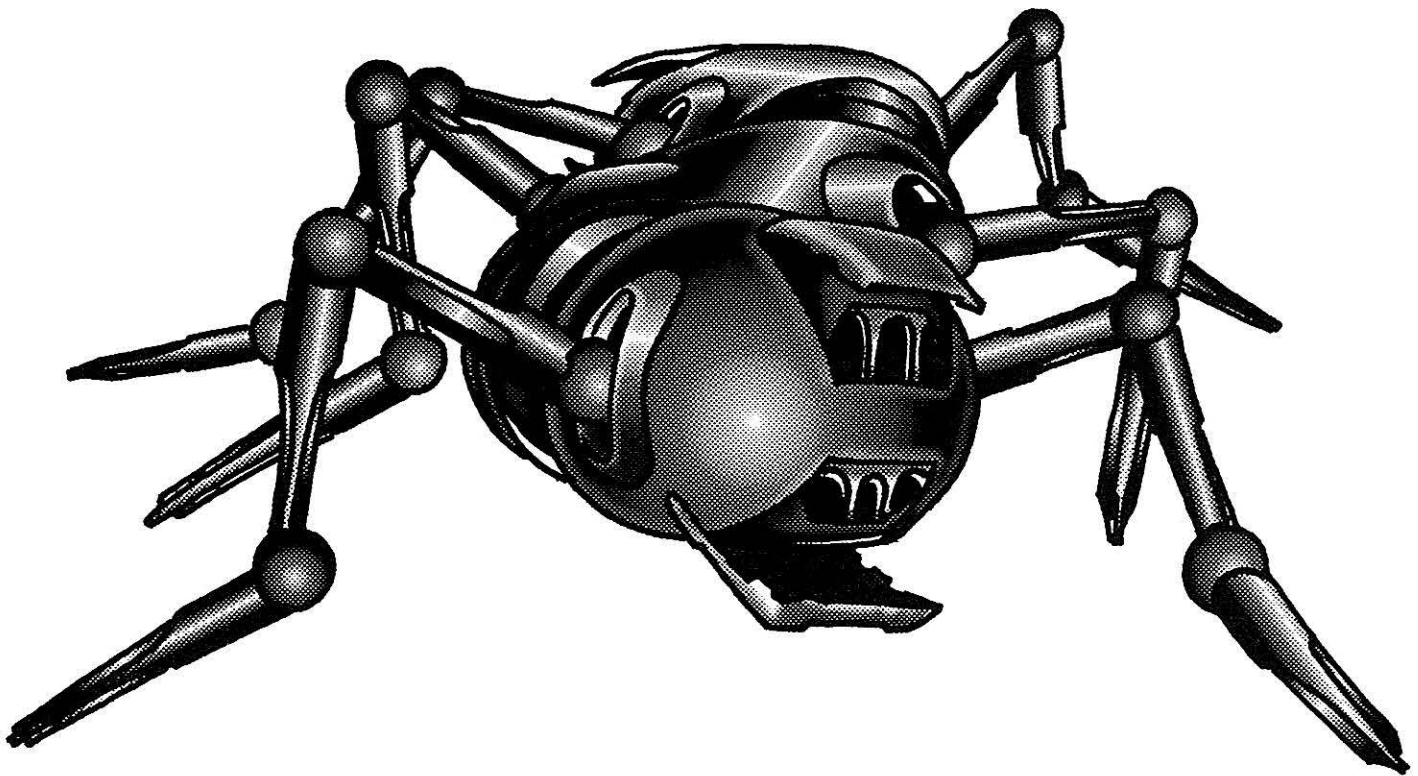

NE AP/ATM-5 "Crawler" Walking MLM

By Patrick Nowak & Kevin Siembieda

The "Crawler" MLM is a dual purpose, anti-personnel and anti-vehicle smart bomb that looks more like a robot than a missile. It is a black, six-legged, self-propelled device that is about the size of a coffee table – 4 feet (1.2 m) long and two and a half feet (0.7 m) wide. Crawling low to the ground, it circumvents detection by radar and has a minimal chance of being detected under the cover of darkness, (cannot be detected at all beyond 100 feet/30.5 m). The big difference is that the "Crawler" is armed with a pair of mini-missile launchers that can be fired at one or more specified targets. As an MLM, the Crawler can get close or underneath a target and self-destruct, taking its target with it. However, depending on the mission and its programming, the Crawler can instead come back for a reload. **Note:** Always self-destructs when captured.

The Crawler is intelligent enough to avoid detection until it is too late. It can navigate across rugged and uneven terrain, fit through large tunnels and pipes, crawl through windows, slide underneath vehicles, climb up inclines as steep as 80 degrees and all the while move silently (equal to a 60% Prowl skill).

Typically, the Crawler MLM stations itself by a road junction or other highly traveled position and waits for an approaching target, steps into its path, tucks in its legs (looks like a low rock or pile of debris) and waits for the vehicle to roll over it (or come within its blast radius) before detonating. If no targets present themselves within a specified time frame (default setting is 48 hours), the device will go on patrol within a specified range (no more than 20 miles/32 km) and engage all targets of opportunity. It can also be sent against fortifications and entrenched positions as well as to circumvent (penetrate) fortifications and barriers to

strike at communications and sensor arrays, ammo dumps, barracks, armored vehicles, and so on. A photo can even be scanned and the Crawler dispatched to locate and blow up a specific individual! Once the MLM has acquired a target it crawls after it, even into foxholes, trenches and bunker complexes. The mine can even be programmed to infiltrate an enemy compound, bypassing its defenses and crawling into a key area like a command hootch or barracks before launching its mini-missile payload or detonating.

For rapid, easy deployment, or delivery behind enemy lines, the Crawler MLM can be dropped by an aircraft with a small detachable parachute (01-96% chance of surviving the landing without malfunction).

Weight: 160 lbs (72 kg).

M.D.C. by Location:

Head/Mini-Missile Launcher – 80

Legs (6) – 30 each

Main Body – 150

Speed: 30 mph (48 km/Spd. 44).

Mega-Damage: Mini-Missiles vary by type; typically heavy ones (1D4x10 M.D. or 1D6x10 M.D.) are used. The Crawler itself can detonate to inflict 2D4x10 M.D. to a blast radius of eight feet (2.4 m).

Rate of Fire: A single mini-missile at a time or a volley of 2, 3, 4 or 6.

Missile Payload: Six total, three in each launcher.

Combat Programming: A combat program enables the MLM to recognize, locate and identify targets 89%, hide and Prowl at 60%, Land Navigation 89%, Detect Ambush 55%, Detect Concealment 48%, and identify up to 1000 different targets.

Bonuses: +2 on initiative, +3 to strike, +2 to dodge.

Attacks Per Melee: Three, for the purposes of dodging incoming fire (if detected), and launching its payload of mini-missiles.

Sensors & Optics: Infrared and passive nightsight (3000 foot/914 m range), motion detector and mini-radar (can track up to 12 targets, one mile/1.6 km range).

Cost: 575,000 credits (triple on the Black Market where they are rare).

K-HEX Explosives

Naruni Enterprises' most famous explosive is called K-HEX (Killaryte High Explosive). Killaryte is a strange crystalline substance found only on a few planets in the Three Galaxies. Researchers have determined that Killaryte is created through the same natural process as coal and petroleum – decomposed organic matter subjected to enormous pressures deep underground. Whereas petroleum and coal are flammable, however, Killaryte is extremely explosive; about ten times more explosive than conventional explosives. The crystals are also ten times more unstable than nitroglycerin, so even minor vibrations could detonate it! Somehow, Naruni Enterprises has been able to stabilize Killaryte and manufacture a chemical explosive more powerful than plasma explosives.

K-HEX products include plastique cubes, explosive ammunition, grenades, and an entire line of missiles. A number of military organizations in the Three Galaxies have conducted tests with the new explosives, which have exceeded expectations on every front. Naruni Enterprises is just beginning to introduce these weapons to other markets in the Megaverse, including Rifts Earth. The corporation is confident it can corner the explosives market in a matter of years. The only obstacle to this plan is the price of K-HEX; the substance is a lot more expensive than conventional explosives.

There are no natural deposits of Killaryte anywhere on Rifts Earth. This crystal is native to the Three Galaxies, and the only way to obtain it on Earth is to purchase K-HEX from Naruni Enterprises. **Note:** Availability on Earth, even from Naruni Enterprises, is poor at best and dealers sometime increase the selling price by 50-200%.

K-HEX Plastique Cubes

K-HEX cubes are sold in units of one pound (0.45 kg). These cubes are as easy to mold as Silly Putty, and can only be exploded with a detonator or by triggering an explosion on top of them. They are ideal for breaking through ship bulkheads, hatches, safes, and security doors. The substance is also used to

make booby traps and improvised mines. A Demolitions skill roll is necessary to get the most out of the explosion. A failed roll means the explosive does 1/5 of its normal damage.

A one pound cube of K-HEX does 1D6x10 M.D. to a 20 foot (6.1 m) area. By molding it around an object, the damage can be focused and doubled. Used as a thrown weapon, the cubes are not very effective; damage is reduced to 5D6 M.D. to a 10 foot (3.0 m) area.

Cost: 250 credits per cube.

NE-10G Grenades

A new line of Naruni Enterprises grenades use K-HEX. They are the NE-10G grenades and come in fragmentation and high explosive variants. These grenades can be used on any standard grenade launcher weapon system, including Naruni's new "Double Threat" assault rifle. NE-10G grenades can be thrown or fired from a launcher and their hand-set timers can delay detonation for up to one minute, or can be set to go off as quickly as two seconds.

Fragmentation: 4D6 M.D. to a 30 foot (9.1 m) area.

High Explosive: 6D6 M.D. to a 12 foot (3.6 m) area.

Cost: 500 credits for fragmentation and 600 credits for high explosive.

NE-20G Micro-Grenades

The enhanced power of K-HEX grenades has allowed Naruni Enterprises to produce a line of small grenades about half the size of a shotgun shell and which are roughly as powerful as conventional hand grenades! The small size of the NE-20Gs makes them ideal for grenade launchers from any manufacturer. They are also useful for spies and assassins, because the little explosives can be easily disguised as harmless items like lipstick, marker pens, flashlights, etc.

Fragmentation: 3D6 M.D. to a 20 foot (6.1 m) area.

High Explosive: 4D6 M.D. to a 6 foot (1.8 m) area.

Cost: 300 credits for fragmentation or 350 credits for high explosive.

Explore the Palladium Megaverse®

The Palladium “Fantasy” Role-Playing Game®

A world of epic fantasy, incredible magic and amazing beings including the shape-changing Changeling, ferocious Wolfen, monstrous Melech, dragons, giants, trolls, dragons and creatures that defy description. Players can create scores of human and inhuman characters.

Combat is fast and fun.

Magic is different! There is spell casting wizardry, the wards of the Diabolist, the circles of the Summoner, and the powers of Druidism. Plus the mind-powers of the Mind Mage, elemental magic, the enchantments of the Alchemists, the blessings of the priest, the dark magic of the witch and magic items and creatures galore.

Sourcebooks define the world, offer new types of player characters, different player races and monsters, adventures and/or adventure ideas. This line is currently Palladium’s second best seller (behind *Rifts*® and just edging out *Heroes Unlimited*™). • \$26.95 — 336 pages.

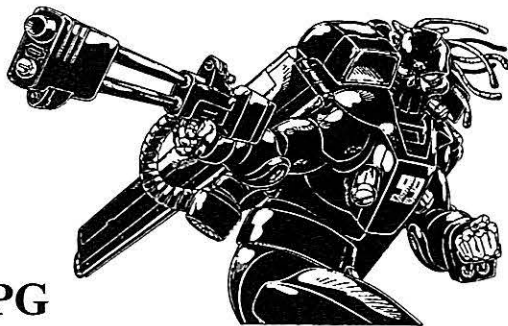

Rifts® RPG

Dimensional *Rifts* are tears in the very fabric of space and time. Portals to other worlds. Doorways that allow the incredible, monstrous and magical to invade our world. Reshaping it into an alien landscape that is both frightening and wondrous, alien and yet strangely familiar.

Super-science, bionics, power armor and robots collide with the forces of magic, Techno-Wizardry, dragons and demons from the Rifts. Humanity struggles on the brink of extinction, and the possibilities are endless.

Discover a world where anything is possible and you are limited only by your imagination.



Heroes Unlimited™ RPG, 2nd Ed.

A big, fun, 352 page role-playing game that presents everything one needs to create a world of super beings.

Aliens, mutants, robots, cyborgs, super-soldiers, psychics, super-sleuths, martial arts masters, gun-toting vigilantes, super-geniuses, masters of magic, demigods, Mega-Heroes and more!

Over 100 super abilities, plus scores of sub-powers and 40+ psionic powers. Over 100 magic spells, plus enchanted weapons and objects.

Everything one needs to play other than dice and friends are in this complete role-playing game. Cover by Jim Steranko. Written by Kevin Siembieda • \$26.95 — 352 pages.

After the Bomb® RPG

Discover the world of mutant animals. Play it as a stand-alone game environment or combine it with *Heroes Unlimited*™, but check it out.

Mutant animal creation rules that make building your mutant characters fast, fun and challenging. Over 100 mutant animals presented. More than 40 animal powers and psionics; many more if you include weird abilities exclusive to certain animal species. • \$20.95 — 224 pages.

Ninjas & Superspies™ RPG

Over 40 different types of martial arts, oriental mysticism, and superhuman abilities combined with spies, gizmos, super-vehicles, cybernetic implants and disguises, and more to create the ultimate spy and combat game. A complete role-playing game with everything you need to play. A complete game in itself as well as completely interchangeable with *Heroes Unlimited*™. Written by Erick Wujcik. • \$20.95 — 224 pages.

Nightbane® RPG

The world has never been the same since Dark Day. Some say the world governments have been supplanted, taken over by ... god only knows what. That doppelgangers can steal one’s identity and life, and that demons and monsters lurk in the shadows. Creatures of evil who serve the Nightlords.

But the lords of shadow are not unopposed. There are creatures of light as well as creatures born from darkness but champion the light. These are the Nightbane. Ordinary people, many teenagers, able to shed their human facade and assume a supernatural alter ego. A monstrous, inhuman visage imbued with superhuman power and the stuff of magic. Written by C.J. Carella. • \$20.95 — 224 pages.

Beyond the Supernatural™ RPG

A game of horror, mystery, & dark secrets

BTS-2™ is a stark, plausible reality where ghosts, demons, psychics, and magic are real, yet remain unknown to the world at large. Player characters are part of the secrets, part of the problems, and humanity’s only true hope of dealing with the unexplained. Truly unique characters that will challenge and excite those who play them. New P.C.C.s include the Psychic Medium (and Spirit Guide), the Diviner and Autistic Psychic Savant, all with new and unique abilities. Characters like the Psychic Sensitive, Nega-Psychic and other original P.C.C.s get a face-lift, new powers, and more details. The secrets of the supernatural, ESP, and magic revealed. • \$22.95 — 192 pages. Written by Kevin Siembieda and Randy McCall.

Splicers™ RPG

Splicers™ is a new science fiction RPG set on a devastated world where machines rule, and human beings are vermin who are hunted and exterminated. The human struggle is complicated by a nano-virus that instantly turns metal objects touched by human flesh into killing machines. Consequently, humans have been forced to turn to organic technology to battle the world-dominating machines if they hope to reclaim any portion of their planet for themselves. Mega-Damage System — compatible with *Rifts*®, *Phase World*®, *Chaos Earth*™ and *Mechanoid Space*™. • \$22.95 — 192 pages. Written by Carmen Bellaire.

Palladium Books Inc.
12455 Universal Drive

Taylor, MI 48180 USA
www.palladiumbooks.com

Copyright 2004 Palladium Books Inc. All rights reserved, worldwide. Palladium Books®, Rifts®, Megaverse®, Nightbane®, The Mechanoids®, and After the Bomb® are registered trademarks of Palladium Books Inc. Heroes Unlimited, Ninjas & Superspies, Beyond the Supernatural, Splicers, and Rifts® Chaos Earth are trademarks owned and licensed by Palladium Books Inc.

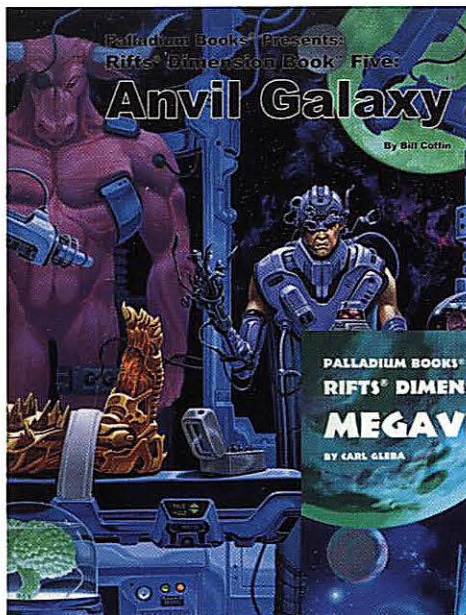

Available at
stores
everywhere

Also from Palladium Books®

The Rifter®

An ongoing sourcebook series for the entire Palladium Megaverse®. Each issue has optional (sometimes official) material for **Rifts®** and other Palladium RPGs.

- Optional O.C.C.s, monsters, weapons, and skills.
- Optional magic and/or super abilities.
- Adventures, gaming tips and Q&A.
- Rifts® source material & fiction.
- HU2, Palladium Fantasy & Nightbane® typical.
- The latest news and sneak previews.
- \$9.95 – 96 pages.

The Anvil Galaxy™

- Overview of the galaxy, the Threshold & the Core.
- Nearly 20 new alien races, including Star Elves & Zebuloids.
- Legends of the Cosmic Forge, Forge War & Cosmo-Knights.
- Planet creation rules and tons of adventure ideas.
- \$17.95 – 160 pages.

Megaverse® Builder™

- The Shifter expanded: his abilities and familiars.
- Two other O.C.C.s, new monsters, critters and weirdness.
- Rules and guidelines for creating alien dimensions.
- Dozens of Hook, Line & Sinker™ adventures and more.
- \$13.95 – 96 pages. Written by Carl Gleba.

Explore the Megaverse®

Naruni™ Wave 2 Rifts® Dimension Book Eight

Naruni Enterprises, arguably the most famous weapons dealers of the Three Galaxies, if not the entire Megaverse, have returned to Rifts Earth. This time it's personal as the Naruni are looking to stick it to the Coalition States, Northern Gun and others who helped the CS oust them from the planet before the Siege on Tolkeen. And they're doing it by selling weapons and armor to all of the Coalition's enemies.

A sourcebook filled with high-tech weapons, body armor, power armor, robots, vehicles and background on the Naruni. Alien technology, exotic weapons and ideas that will drive players wild; brought to you by Naruni Enterprises, the arms dealer with a heart (for revenge).

- More than 20 new weapons – pistols, rifles, rail guns, and more.
- Six new types of body armor, and seven new power armors – some with innovations that will blow you away.
- Five different robots, plus hovercycles, tanks and aircraft.
- Thermo-Kinetic Armor, Ripper Vibro-Swords, robot combat drones, the Sun Chariot and much more are part of this dynamic sourcebook.
- A perfect companion (and sort of preview) to the upcoming Rifts Mercenaries/Merctown sourcebooks.
- \$13.95 – 96 pages. Written by Siembieda, Bellaire and others.

**Rifts®, endless possibilities
limited only by the imagination!™**

\$13.95

Cat. No. 860

ISBN No. 157457-102-8

ISBN 1-57457-102-8



9 781574 571028