

# LEGENDS & LAIRS

5E  
system

## TRAPS & TREACHERY II

A SOURCEBOOK OF MORE  
DEADLY MACHINATIONS

Requires the use of the  
Dungeons & Dragons® Player's Handbook,  
Third Edition, published by Wizards of the Coast®

# LEGENDS & LAIRS

20  
system

## TRAPS & TREACHERY II



A SOURCEBOOK OF MORE  
DEADLY MACHINATIONS

# TRAPS & TREACHERY II

---

## CREDITS

### LEAD DEVELOPER

Wil Upchurch

### MANAGING DEVELOPER

Greg Benage

### WRITING

Ed Bourelle, Kurt Brown, Shaun Cashman, Mark Chance, Catten Ely, Lizard, Brian Patterson, Scott Stoecker, Paul Sudlow, William Timmins, Bree Zastrow

### INTERIOR ILLUSTRATIONS

Toren "Macbin" Atkinson, Paul Butler, David Griffith, Kenneth Kay, Brian Schomburg, Chris Seaman, Tyler Walpole

### GRAPHIC & COVER DESIGN

Brian Schomburg

### EDITING

Greg Benage & Wil Upchurch

### ART DIRECTION

Wil Upchurch

### LAYOUT

Wil Upchurch

### PUBLISHER

Christian T. Petersen

### PRINTING

Bang Printing

'd20 System' and the 'd20 System' logo are Trademarks owned by Wizards of the Coast and are used according to the terms of the d20 System License version 1.0. A copy of this License can be found at [www.wizards.com](http://www.wizards.com).

Dungeons & Dragons® and Wizards of the Coast® are Registered Trademarks of Wizards of the Coast and are used with permission.

## FANTASY FLIGHT GAMES

1975 W. County Rd. B2

Roseville, MN 55113

651.639.1905

[www.fantasyflightgames.com](http://www.fantasyflightgames.com)



# TRAPS & TREACHERY II

## CONTENTS

### CHAPTER ONE

NEW TRAPS: CR 1-5

5

### CHAPTER TWO

NEW TRAPS: CR 6+

78

### CHAPTER THREE

NEW POISONS

133

### CHAPTER FOUR

PUZZLES & CHALLENGES

154

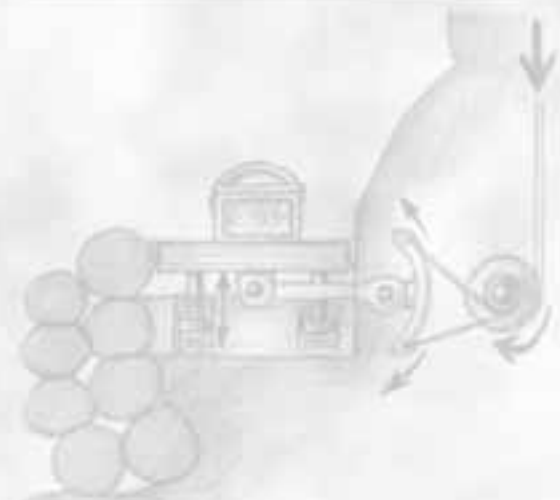

# INTRODUCTION

Emile Zola once said that the artist is nothing without the gift, but the gift is nothing without work. Putting together a book of this magnitude would not be possible without the hard work of many talented people. It is truly a group effort, and is every bit as satisfying as anything I've done in my life.

The task at hand this time was to follow up one of the most successful d20 releases of all time, *Traps & Treachery*. In some ways it was easy, the formula for success having been crafted before my arrival. In other ways it became a challenge to recreate that formula while putting forth a novel product that had the same electric feel to it. I believe that we have succeeded at this task, and I am proud to present you with *Traps & Treachery II*.

To all the players out there who have grown attached to their characters—I'm truly sorry.

Wil Upchurch  
Fantasy Flight, Inc.

## WELCOME

Fantasy Flight Games is pleased to present *Traps & Treachery II*, the fifth volume in our Legends & Lairs line of sourcebooks for the d20 System. *Traps & Treachery II* follows in the footsteps of its predecessor, offering even more fiendish traps, mind-bending puzzles, and heroic challenges that DMs can foist upon their players.

Chapter 1 and Chapter 2 contain more than 100 new traps to add to your game. Ranging from the simple traps of goblin and kobold tribes to the most nefarious magical inventions of the famed trapsmiths Perivax and Blackstone, these traps present a plethora of deadly options to throw against characters of any power level.

Chapter 3 details more than 80 new poisons, both mundane and magical, that can be used by players and NPCs alike. Several new types of poisons, including monstrous and prankster poisons, are detailed. In addition, this book presents new rules detailing the rarity of

poisons and the effects this can have on the game.

Chapter 4 presents tricks, puzzles, and challenges aplenty, providing hours of thought-provoking fun for both players and DMs. These situations offer characters a chance to highlight their non-combat skills and players a chance to exercise their brains.

## THE OPEN GAME LICENSE

*Traps & Treachery II* is published under the terms of the Open Game License and the d20 System Trademark License. The OGL allows us to use the d20 System core rules and to publish gaming material derived from those rules.

Material that is strictly rules related is Open Game Content. You can use this material in your own works, as long as you follow the conditions of the Open Game License. You can copy the material to your website or even put it in a book that you publish and sell.

Not everything in this book is Open Game Content, however. The names, mechanics, and game statistics of races, feats, skills, equipment, spells, and magic items, and rules derived from the d20 SRD are designated as Open Game Content. Descriptive text, unless otherwise noted, is closed content and cannot be republished, copied, or distributed without the consent of Fantasy Flight Games. A note at the beginning of each section describes the open and closed content found within.

All illustrations, pictures, and diagrams in this book are Product Identity and the property of Fantasy Flight Games, © 2002.

The Open Game License is printed in its entirety at the end of this book. For further information, please visit the Open Gaming Foundation website at [www.opengamingfoundation.org](http://www.opengamingfoundation.org).

# CHAPTER ONE

# NEW TRAPS:

# CR 1-5

CHAPTER ONE: NEW TRAPS: CR 1-5

*The dwarf moved down the passage, grumbling. Cress tried to hush the dwarf, fearing the tomb's ancient guardians would awaken to silence his complaints permanently. The tall human kept his rapier in his hand, even though he was certain it would be of no use should they encounter the spirits of the dead. He could smell the combined stench of sweat and leather as he fought to control his fears.*

*"Dammit, Sarina, if your god is protecting us I sure can't feel it," he said.*

*"Quiet down up there," said the priestess as she clutched the miniature silver harp that hung from a chain around her neck. "Rudan is the god of music and revelry, not silent death. Still, I have faith he will protect us from the horrors of this place."*

*The three companions continued creeping down the dark hallways, thankful their short friend could see through the shadows beyond their torchlight. Suddenly from up ahead they heard several voices crying out in the barking language of gnolls.*

*"They want us to throw down our weapons and surrender," said Sarina.*

*"Dammit, I can't see them!" said the dwarf.*

*"Nor can I," said Sarina, "they are beyond our torchlight. They say they are wielding bows!" Sarina turned to her companions, trusting their adventuring instincts far beyond her own.*

*"Quick, into those alcoves just ahead!" said Cress as he tumbled toward the left side of the corridor to avoid any oncoming arrows. In one swift motion, the black-clad rogue sprang to his feet and drew his crossbow.*

*The dwarf was about to follow his lead, but just as he started to jump to his right he saw the floor underneath the rogue rise up and dump him into a chamber beyond.*

*"Sarina, it's a trap!" said the dwarf. He then lowered his head and charged the gnolls, cursing their decision to come into this unholy place.*

## INTRODUCTION

This chapter presents full descriptions, game statistics, and illustrations of a variety of magical and mechanical traps. The trap names and statistics, as well as rules and mechanics derived from the d20 SRD, are designated as **Open Game Content**. Background text and trap descriptions are designated as closed content.

Several new concepts are introduced in this book in relation to the traps found herein. These new concepts are explained below.

## OUTDOOR TRAPS

In outdoor surroundings a character must use a Wilderness Lore check to place a trap; a Craft (trapmaking) check can still be used, but a -5 penalty is applied to the check as most traps rely on structures such as walls and rooms to hide their apparatuses. The Search DC required to find traps in the outdoors can actually increase over time due to the growth of underbrush and other such obstructions that hide any visible mechanisms.

To detect such traps, a character may use either Search or Wilderness Lore. If the character has 5 or more ranks in the skill he chooses not to use, he gains a +2 synergy bonus on his check. So, if a ranger with 6 ranks in Search decides to use his Wilderness Lore skill to search for traps, he gains the synergy bonus on his Wilderness Lore check.

Outdoor trap rules apply to any region that has wild vegetation or broken up landscape, and natural paths through these areas. It does not apply to roads, areas of worked stone, or similar surroundings.

## LARGE SCALE TRAPS

Traps are very much a staple of fantasy settings, from the poison needle of the common treasure chest to the morbid death oubliettes of the Snake King. It only stands to reason that, in such a culture, trap makers would be pressed into service by their rulers and commanders to create huge or elaborate traps designed to confound or destroy large numbers of warriors at a time, especially in siege settings. Thus you will find within these pages a number of large-scale traps that target dozens, rather than one or four victims at a time.

Here are some ideas on bringing such traps into the campaign:

**Battle:** The characters are enlisted in a battle against an enemy city or castle. Encountering a siege trap as a victim makes for an exciting moment, of course. If you wish to make the trap more central to an adventure, perhaps the characters are assigned the task of infil-

trating the castle or city and disarming the siege traps before a major offensive commences.

**Espionage:** The characters are hired to learn all they can about a city's defenses, including the existence and weaknesses of any hidden siege traps. This may entail bribing or blackmailing a few city officials as well as a good deal of skulking about in borrowed uniforms.

**Exploration:** Abandoned cities that have fallen into ruin hide many secrets—some of which may be long forgotten siege traps still armed and dangerous. Imagine the character's surprise and dismay if in entering a lost city they activate a massive unhinged wall or jaw gate.

**Accident:** A large-scale trap is accidentally tripped and the characters are either in its path or must protect those who are. The Well of Tentacles is an excellent candidate for this sort of scenario.

**Terrorism:** Someone, either an enemy outsider or unbalanced city official, is running around town activating all of the siege traps, which makes leaving or entering the city a dangerous proposition.

## TRAP ENHANCEMENTS

The following ideas are not pure traps per se; they are ways to make traps more cunning and deadly, especially for high-level parties that might trivially overcome many challenges.

### INVISIBLE MECHANISMS

The mechanics of a trap can be made *invisible*. This can be done by a 3rd-level mage with access to Craft Magic Trap and the *invisible object* spell from *Traps & Treachery*. The cost is 500 gp over and above any other costs for the trap. The effect is to make the trap much harder to detect, adding +5 to the DC of detecting the trap, and even then, the DM must rule there is some method of sensing or inferring that the trap is there. This enhancement is used primarily on locks, but is also useful anywhere a rogue visually inspects a mechanism for signs of a trap. Even if the trap is detected, Disable Device check DCs are also increased by 5, simply because it is harder to work on what you cannot see.

This adds +2 to the CR of the trap.

## SUGGESTION GEMS

A *suggestion gem* is created via the Craft Magic Trap feat, requiring a 5th-level caster with the ability to cast *suggestion*, 2,500 gp, and 100 XP. The gem is then integrated into an area near a trap, usually as part of a wall decoration or a mosaic on the ceiling. The *suggestion* made is invariably some action that will trigger the trap, causing invaders or thieves to pull random levers, place their hands into alcoves, look through peepholes, hastily grab the idol from the pedestal, and otherwise act without caution.

Once removed from its location, the magic of a *suggestion gem* is broken, although it is still a high-quality gem (usually worth 500 gp or more).

This adds +2 to the CR of the trap.

## ILLUSION DISGUISE

A relatively simple figment can be placed over the internal workings of a trap, making it seem to be a completely different trap and otherwise making it much harder to disable. In addition, illusions can be used to cover up joined stonework, hide pressure plates, conceal the space in the ceiling in which a deadfall is hidden, and so on. A mage with access to Craft Magic Trap and *silent image* can enhance a physical trap with an illusion for a cost of 500 gp and 20 XP. These illusions can have a range of effects, but the most common are:

**Disguise the mechanism.** This adds 5 to the Disable Device DC, unless the character makes a successful Will save (DC 15).

**Disguise the trap.** This adds 10 to the Search check to notice the trap, unless the character succeeds at a Will save (DC 15).

This adds +1 to the CR of the trap.

## SPRING LOADED

Some trap mechanisms are designed to work exceptionally fast, so fast that even a skilled rogue might find himself taken by surprise. A spring-loaded trap is usually placed on a chest or a door lock, and the primary effect is to negate all or part of a rogue's enhanced resistance to traps. For 2,000 gp, the trap negates the rogue's evasion ability. For 500 gp per

point of negated bonus, the trap negates one point of the rogue's uncanny dodge save bonus against traps. (In other words, for 500 gp, the uncanny dodge bonus is reduced by one, 1,000 gp buys a two point reduction, and so on.) The bonus can never be reduced below 0.

This adds +1 to the CR of the trap.

## FALSE DISABLING

It is a fact known to every trapmaker that, sooner or later, someone will try to disable his creation. Some focus solely on making better traps, while others try more devious tricks. This is an example of the latter. A False Disabling trap is designed to appear trivial to disable—an obvious wire must be cut, an obvious piece of metal must be bent back. Unfortunately, this action will not disable the trap, but will trigger it. The true DC of disabling the trap is unchanged, but it appears to be a much simpler mechanism than it really is, thus encouraging rogues to make a try at a task they might not be prepared for, take fewer precautions, etc. Any failure will trigger the trap. A Spot check (DC 25) is allowed just before the disable attempt to reveal the subterfuge.

This adds +1 to the CR of the trap.

## FALSE TRAPS

False traps are slightly less lethal than normal traps but far more frustrating. The main purpose of such traps is to confuse or slow a party of invaders while keeping the cost of building traps considerably lower than normal. For 100 gp, a skilled craftsman can create the appearance of hairline seams in a wall, construct an elaborate but meaningless mechanism in a lock, or set stones in a pathway so that they appear to be trigger plates. It requires a successful Spot check (DC 20) to identify a false trap for what it is. Any Disable Device checks automatically fail, but with each attempt the character gains a new Spot check to note the deception.

One particularly fun false trap, called False Hollow, requires Craft Magic Trap, *ghost sound*, 500 gp, and 20 XP to build. Characters who tap a wall or otherwise look for hollow spaces hear the faint echo that indicates a passage lurks just beyond a seemingly solid wall. Tremendous amounts of time could be spent looking for a secret door, or just



trying to break down the wall. (If more than five cubic feet of stone is removed from the wall in which a False Hollow has been placed, the spell is broken.) This false trap's primary use is to keep a party occupied, and noisy, thus attracting guards and keeping the party in one place while the guards approach.

False Traps should be considered CR 1 to 3, and the DM should consider an ad hoc XP award to any character that figures out the ruse without resorting to skill checks.

### LOCKPICK DESTRUCTION

There are several locks, usually door and chest locks, which are designed with complex mechanisms whose purpose is not to damage the thief, but his tools. The nasty bit is that in order to disarm these traps you need to put your tools into them, making even the slightest error extremely annoying.

Two common variants are the acid trap and the locking trap.

The acid trap usually has interior components made of ceramic and glass, or else the metal components are alchemically treated to resist acid. On any failed Open Lock or Disable Device check, the acid pours over the picks, destroying them unless the rogue succeeds at a Reflex save (DC 25) to yank them back. The rogue's bonus to Reflex saves due to uncanny dodge applies to this check.

The locking trap uses a set of gears and springs to clamp down on any picks or probes that have entered the lock. The picks are then held in the lock. Removing them without breaking them is difficult, requiring a successful Disable Device check (DC 25). Failure means that the tools are broken and the lock has been jammed or damaged, causing additional Open Lock checks to suffer a -4 penalty.

Locks with these mechanisms are considered CR 1.

## NEW TRAPS

The traps found within these pages are organized according to Challenge Rating, from lowest to highest.

## ALL WRAPPED UP

**Trap Type:** Binding Trap  
**Construction Type:** Magic  
**Activation Type:** Instant  
**Trigger:** Local; magic  
**Mechanism:** Magic  
**Effect:** Hindrance  
**Attack Bonus:** No attack roll necessary  
**Damage:** None  
**Save:** Reflex save (DC 14) avoids  
**Search DC:** 26  
**Disable Device DC:** 26  
**Challenge Rating:** 1  
**Construction Time/Cost:** 1 day; 500 gp; 20 XP

This is an amusing trap that is usually combined with an alarm. One big advantage of the trap is that it is not very dangerous. This is useful for inhabited buildings, where a servant or visitor can get lost.

When a character steps on the trap's symbol, *animate rope* is cast. This causes any rope that is carried by the character to move and *entangle* the bearer. If the target is not carrying any rope, the trap triggers but has no effect. The trap could be used on an item, perhaps with a command word override. Sometimes a rope is placed nearby so that the trap cannot fail. It is often hidden within a chandelier or curtain so as to avoid tipping off observant trespassers.

Subtle signs of struggle around the trap provide a clear sign for observant rogues. The wear marks are unusual, compared to normal traffic. The symbol is repeated elsewhere, but is engraved a bit more precisely here.

## CLOAK AND DAGGER

**Trap Type:** Pit Trap  
**Construction Type:** Simple mechanical  
**Activation Type:** Instant  
**Trigger:** Local; switch  
**Mechanism:** Gravity  
**Effect:** Ensnarement  
**Attack Bonus:** No attack roll necessary  
**Damage:** 2d6  
**Save:** Reflex save (DC 17) negates  
**Search DC:** 20  
**Disable Device DC:** 20  
**Challenge Rating:** 1  
**Construction Time/Cost:** 1 week; 1,000 gp

The Cloak and Dagger trap has two parts: one to fool victims and the other to catch them. It is primarily used by primitive humanoids such as kobolds and goblins to capture creatures that might be too powerful for them in a straight fight. The first part of the trap involves a wooden cage suspended in the branches of a tree by a single rope. About four feet from the trunk is a dagger pinning an old, ratty cloak, usually of a bright color, to the tree. The cloak semi-hides the rope, which is also pinned to the tree by the dagger. Removing the dagger releases the rope and drops the cage.

However, this is meant only as an obvious ruse. A character notices the rope and cage with a successful Spot check (DC 12). What makes the trap truly fiendish are the two 20 ft. deep, 5 ft. by 5 ft. pits on either side of the tree that are hidden by a cloth and covered with dirt. These pits make up the second part of the trap.

A clever individual will probably wish to remove the dagger and follow the old adage that says, "If it isn't nailed down, pick it up." By merely sidestepping the tree and grabbing the dagger from the side, a character does not have to worry about the cage, but falls in a pit instead.

A victim who falls in a pit takes 2d6 points of falling damage and must succeed at a Climb check (DC 20) to get out. A victim who actually fails to notice the cage before it falls may make a Reflex save (DC 15) to jump out of the way (possibly landing in a pit.) An individual trapped under the cage needs to make a Strength check (DC 18) to break free. In order to make the trap even deadlier, the creator may place snakes, scorpions, or other poisonous creatures in the pits.

The dagger is a normal, everyday blade and the cloak is smelly, full of holes, and completely worthless.

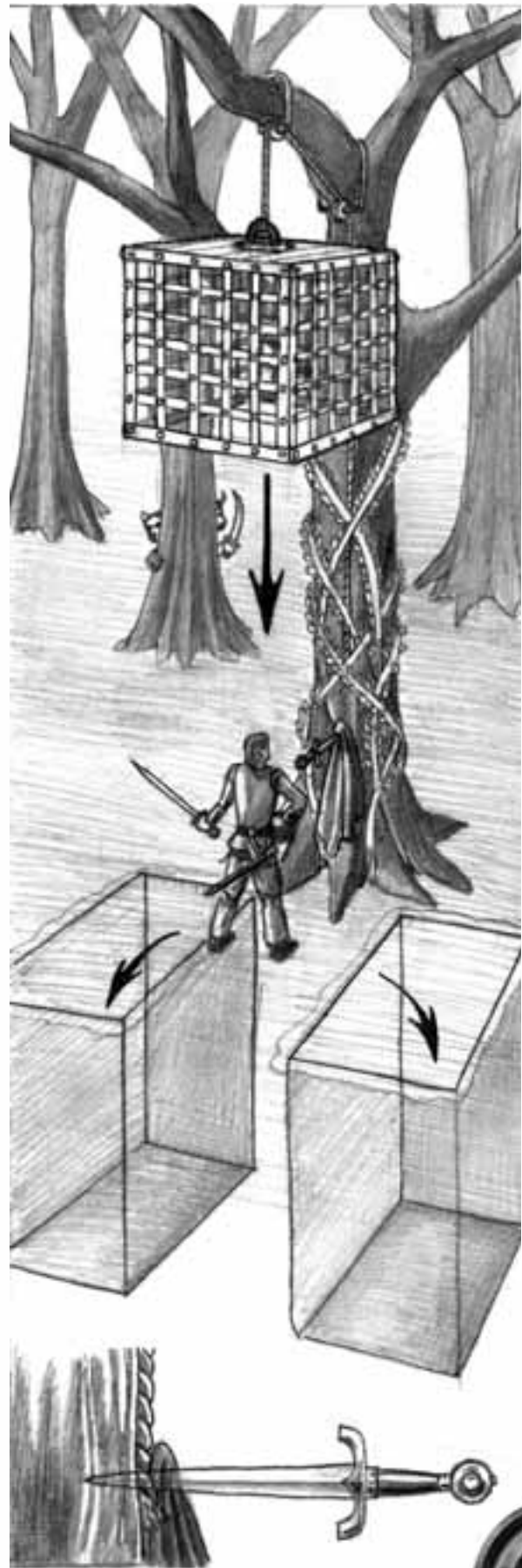

## CROSSFIRE

**Trap Type:** Crossbow Trap  
**Construction Type:** Simple mechanical  
**Activation Type:** Instant  
**Trigger:** Local; pressure plate  
**Mechanism:** Spring  
**Effect:** Injury  
**Attack Bonus:** +10 ranged  
**Damage:** 1d8 per bolt  
**Save:** None  
**Search DC:** 20  
**Disable Device DC:** 20  
**Challenge Rating:** 1  
**Construction Time/Cost:** 1 week; 1,000 gp

Crossfire is a simple mechanical trap designed to harm or kill intruders. The room that holds the trap is a small temple of sorts with an altar at the far end of the room. Raised, brightly colored tiles cover the floor, and the walls and pillars bear paintings that depict the exploits of a god and his followers.

The trap consists of crossbows held in hollow pillars to either side of the door. The pillars are

very close to the wall nearest to the door, so intruders must pass between them. The crossbows fire through small holes hidden in the designs on the pillars.

The trigger for the trap is the tile section between the pillars. As all the tiles are raised, the trigger is difficult to see. Stepping onto any of the trapped tiles sets off the trap. Two bolts, one from each of the adjacent pillars, shoot outwards toward the trespasser. If only one person stepped on the tile, he is the target of both. If two people triggered the trap simultaneously, one bolt is aimed at each. If more than two stepped forward, determine the targets randomly. Each crossbow holds only one bolt, so after one triggering the trap is rendered useless until reloaded.

The simplest way to disable the trap is to plug the holes from which the bolts shoot. Another possibility is to jam the trigger mechanism with pitons. Each pillar has a hidden door (Search DC 17) on the rear side where the trap can be reloaded. 2d4 bolts can typically be found in each pillar, and 30% of the time the bolts will be *blessed*.

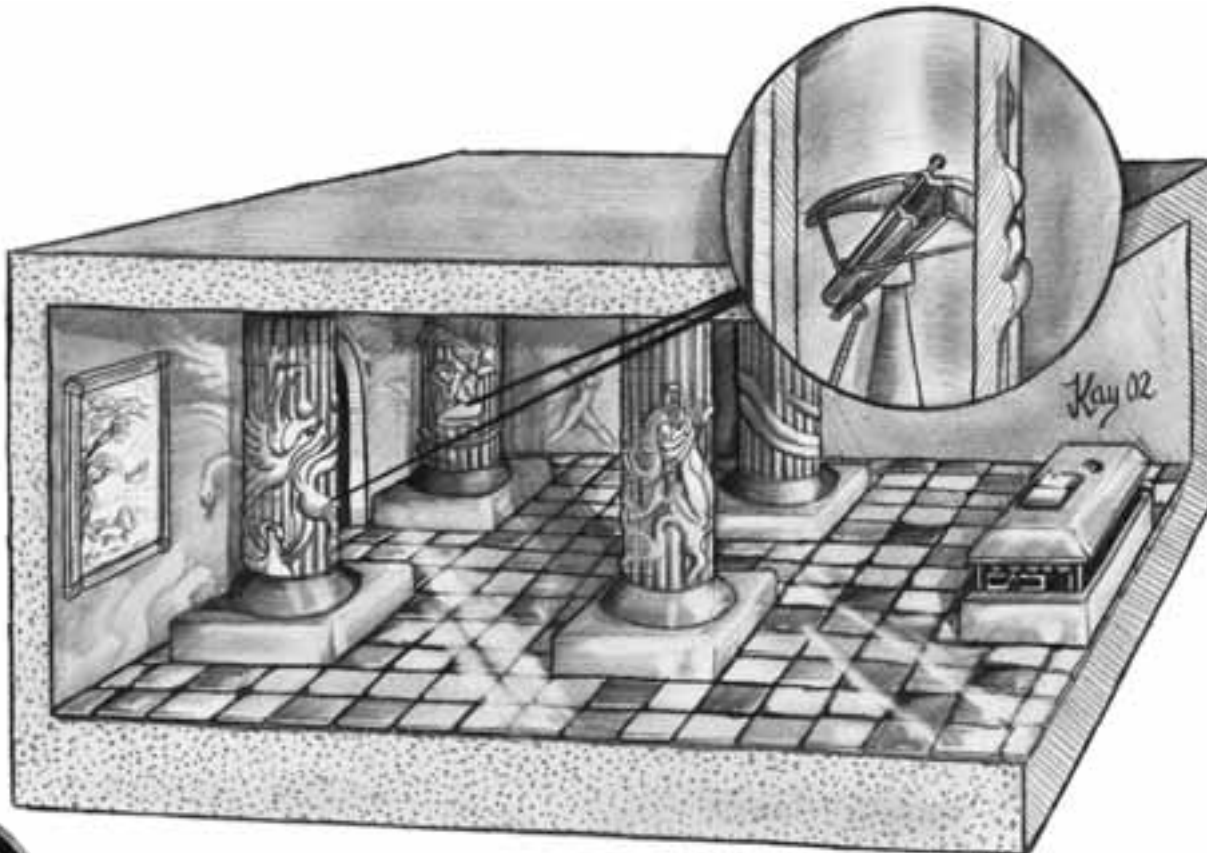

## HANGMAN'S LAST LAUGH

**Trap Type:** Poison Trap  
**Construction Type:** Simple mechanical  
**Activation Type:** Instant  
**Trigger:** Local; tripwire  
**Mechanism:** Tripwire  
**Effect:** Injury  
**Attack Bonus:** No attack roll necessary  
**Damage:** Poison  
**Save:** Fortitude save (DC 18) resists  
**Search DC:** 20  
**Disable Device DC:** 20  
**Challenge Rating:** 1  
**Construction Time/Cost:** 1 week; 1,000 gp

Hangman's Last Laugh is a simple trap typically used by primitive tribes of humanoids, such as goblins and kobolds. The trap uses a decoy to deliver a debilitating poison to curious interlopers. It is sometimes used as a hunting technique, although it is much more commonly seen protecting important tribal areas.

A hanged humanoid body is suspended several feet above the ground, the rope slung over a tree branch or outcropping of rock. The body is dressed normally, though the poor condition of the clothing suggests the body has been in its current position for quite a while. Preservatives are used to prevent rotting, and foul smelling herbs keep scavengers away from the body. A sign hung around the neck reads 'Die filthy human, die!' or something appropriate to the creature hanging there. The words are very small, the sign being designed to bring the victims as close to the poison as possible.

Tripwires are hidden (Spot check DC 15) in the grass surrounding the body. Tripping over the wires causes a small, spring-loaded blade to cut the rope holding up the body, dropping it to the ground. When the body hits the ground it splits open and releases a noxious poison. Moving the corpse causes the body to fall apart as well. The body is held together by crude stitches hidden beneath the corpse's clothing, and the poison gas is sealed in fragile sacks made from specially prepared animal stomachs.

When the body falls apart, the gas is released, affecting all creatures in a 10-ft. radius. Burned barla root is the most common poison used in Hangman's Last Laugh (Fortitude save DC 18, initial damage 1d2 Con, secondary damage 1d4+1 Con).



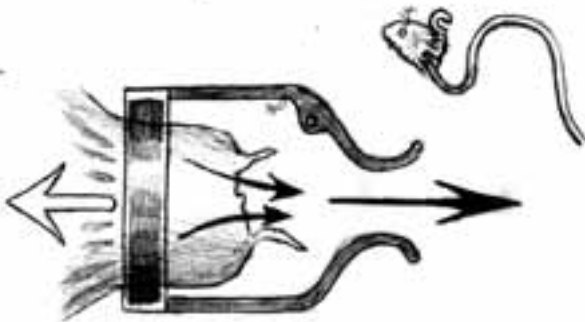
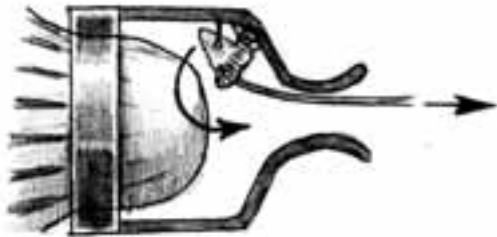

It is easy to avoid the Hangman's Last Laugh by stepping over the tripwire and not touching the body. Otherwise, following the tripwire to its source reveals the blade used to cut the rope (Disable Device check DC 20).

## INK MINE

**Trap Type:** Aquatic Ink Cloud Trap  
**Construction Type:** Simple mechanical  
**Activation Type:** Instant  
**Trigger:** Local; tripwire  
**Mechanism:** Spring, pressure  
**Effect:** Hindrance, identification  
**Attack Bonus:** No attack roll necessary  
**Damage:** None  
**Save:** Reflex save (DC 22) avoids  
**Search DC:** 20 (see text)  
**Disable Device DC:** 20  
**Challenge Rating:** 1  
**Construction Time/Cost:** 1 week; 1,000 gp

Aquatic races use ink mines around the perimeters of their Underdeep lairs to deter trespassers and provide a visual warning to their presence. When triggered, the ink mine launches a specially treated bladder that leaves a trail of opaque squid ink.

The tripwire for an ink mine can be placed along a sea or cavern floor or it can be suspended between two objects such as reef embankments. A suspended tripwire can become covered in drifting sediment and must be cleaned weekly or suffer a  $-2$  to its Search DC for each week that it goes without maintenance. A creature that comes into contact with the tripwire must make a Reflex save (DC 22) in order to stop itself from applying enough pressure to the wire to trigger the mine. Creatures with at least 5 ranks in Swim gain a  $+2$  circumstance bonus to this Reflex save.

When the ink mine is triggered, a piece of coral or other sharp material punctures a hole in the pressurized ink bladder. The release of the ink acts as a propellant, pushing the bladder  $2d4 \times 10$  ft. in a predetermined direction. The cloud, which spreads in a 20-ft. radius along the path of the bladder, provides total concealment and creatures within the cloud suffer the effects of total darkness. In calm water, the cloud dissipates in  $3d6$  rounds.

Although the tripwire for this trap is generally translucent, it is almost always the first thing a

successful Search check (DC 20) reveals. Disabling the ink mine is a simple matter of disconnecting the tripwire or removing the spring from the puncturing device. The delicate bladder holds about a gallon of concentrated ink and requires a Reflex save (DC 15) each round that it is handled to keep it from breaking.

## LONGPIT

**Trap Type:** Pit Trap  
**Construction Type:** Simple mechanical  
**Activation Type:** Instant  
**Trigger:** Local; pressure plate  
**Mechanism:** Gravity  
**Effect:** Injury  
**Attack Bonus:** No attack roll necessary  
**Damage:** 2d6  
**Save:** Reflex save (DC 21) to avoid  
**Search DC:** 20  
**Disable Device DC:** 20  
**Challenge Rating:** 1  
**Construction Time/Cost:** 1 week; 1,000 gp

The basic pit trap has many problems, and trap designers have found many solutions to them over the years. One of the major problems is that most pits will trap one, or perhaps two, intruders at a go, while extensive surveys by trapmaster Acand Deyryn have indicated the average number of individuals invading a complex is four. This makes it trivial for those who have been trapped to escape, if they survive the fall.

The Longpit is a simple, inexpensive, solution to this problem. The pit is usually built in a narrow corridor, and fills an area at least 40 ft. long by 5 ft. wide. The trigger is at the farthest point from the likely entrance to the corridor, so that the entire group will be standing over the mouth of the pit when it opens. The person who triggers the trap (usually the leader of the party) can make a Reflex save to avoid it; the rest simply fall in.

The pit is a minimum of 20 ft. deep, large enough to impose an obstacle when everyone is inside it. The walls are usually polished quite smooth, so climbing out is extremely difficult. (It is also possible to have a single wall that is easier to climb; this is an excellent place to use a Falling Wall or Burning Wall trap).

This trap is used only in areas where intruders are likely to be weak or not well equipped; it

does not pose a serious threat to more advanced adversaries. Detecting it is fairly simple; the very large open area beneath the trap door may echo oddly, and the floor itself vibrates slightly as it is walked upon. Disabling it is likewise simple. Once the trigger plate has been located, even a marginally skilled rogue can easily jam it. However, the low expense and general utility against minor threats makes this trap popular as a filter mechanism; it eliminates weak intruders early, preventing the expense and difficulty of rearming traps that were designed to deal with much more serious threats.

## MANTLE OF DREAD

**Trap Type:** Fear Trap  
**Construction Type:** Magic  
**Activation Type:** Instant  
**Trigger:** Local; magic  
**Mechanism:** Magic  
**Effect:** Hindrance  
**Attack Bonus:** No attack roll necessary  
**Damage:** None  
**Save:** Will save (DC 11) negates  
**Search DC:** 26  
**Disable Device DC:** 26  
**Challenge Rating:** 1  
**Construction Time/Cost:** 1 day; 500 gp; 20 XP

This trap is traditionally placed before the statue of a god. Anyone approaching is subject to the fear effects, and begins quaking in terror. Some temples to war gods place these traps to test the nerve of aspirants. Darker temples use the trap as atmosphere. It can also be placed so as to distract intruders, causing them to run into other, more dangerous traps. If placed near the entrance to a place of solitude or solemnity, it can screen out casual annoyances.

The trigger is based on body heat passing over it. Undead, plants, and other beings with no such heat do not activate the trap. It does not react to torches or other forms of heat, as it specifically keys on the body heat of normal creatures. A heat source like a torch will confuse the trigger, however, and block it.

Once activated, the trap casts *cause fear* on the target. The focus of the dread is typically the statue or icon of a god. The fear could also be of an entrance, or simply a feeling of terror emanating from a specific direction. The effect lasts 1d4 rounds.

The outlines of the trap are not hard to spot. Wavy black lines etched into the ground are clear to the trained eye. Chiseling one of the wavy lines deactivates the trap and its magical trigger.

## MEAL SPEARS

**Trap Type:** Spear Trap  
**Construction Type:** Complex mechanical  
**Activation Type:** Instant  
**Trigger:** Local; pressure plate  
**Mechanism:** Pressure, gear  
**Effect:** Injury  
**Attack Bonus:** +6 ranged  
**Damage:** 1d8  
**Save:** None  
**Search DC:** 21  
**Disable Device DC:** 21  
**Challenge Rating:** 1  
**Construction Time/Cost:** 1 week; 1,000 gp

Meal Spears is a mechanical trap designed to injure the unwary, who may be preoccupied with the room's other element.

The room that contains Meal Spears is a small dining hall, 40 ft. wide and 60 ft. long. A rectangular table surrounded by six short-backed chairs rests in the center of the room. A skeleton sits in the chair nearest to the door the PC's enter through, its skull resting on the table before it. A dagger lies next to the skeleton's head.

Ghostlike images inhabit the room, and they seem to be having a meal. When the characters enter, one of the ghosts, a woman, slowly walks behind the ghost of a man in the position of the skeleton, pulls a knife and sinks it into his back. The other dinner guests rise in shock and horror, and then the image fades out and repeats.

This illusionary dinner is meant to distract the PCs from the waiting trap. Underneath the skeleton's chair is a cleverly disguised pressure plate (Search check DC 21). When any additional weight is put on this large plate (for example, to examine the skeleton or grab the dagger) the trap is sprung. Several shortspears fire from holes in the walls opposite the dead skeleton. Anyone within 10 feet of the skeleton suffers 1d3 spear attacks. The spears have a ranged attack bonus of +6.

Disabling the trap can be accomplished in

two ways, either by jamming the pressure plate or noticing (Spot check DC 18) and plugging the holes from which the spears are fired.

## ROOM OF CUNNING OBSERVATION

**Trap Type:** Magical Detection Trap  
**Construction Type:** Magic  
**Activation Type:** Instant  
**Trigger:** Local; magic  
**Mechanism:** Magic  
**Effect:** Identification  
**Attack Bonus:** No attack roll necessary  
**Damage:** None  
**Save:** None  
**Search DC:** 26  
**Disable Device DC:** 26  
**Challenge Rating:** 1  
**Construction Time/Cost:** 3 days; 2,500 gp; 250 XP

The Room of Cunning Observation is somewhat unique in that characters may very well walk into it, suffer the full effect of the trap, and yet never be aware they have been in a trap at all! The room is usually large, at least 30 ft. long, and placed along a main route through the dungeon. The only exit from the room is a heavy door (Break DC 26) along with a very well made masterwork lock. The function of the lock and the door is to keep the party busy for at least a few minutes. Meanwhile, the trap does its work.

Inlays of semi-precious gems all around the room's walls serve as both decoration and concealment. A small number of these gems are part of a magical scanning system that casts *detect magic* on the party and then relays the results (as well as an image of the party) to a watcher via *clairvoyance*. The watcher thus knows who has the most powerful magic, and has some sense of what those items might be. He also has a chance to listen to any conversation that occurs in the room, which might provide more clues as to the nature of the party members.

Then, armed with this knowledge, dungeon denizens are dispatched to encounter the party later, utilizing their knowledge to the fullest. If someone has a *flaming burst* weapon, for example, they may have prepared with *potions of resist elements (fire)*. Many similar stratagems are possible.

The fact that there is even a trap to detect is somewhat difficult to ascertain. A rogue with a level or two of wizard or one or more ranks in Knowledge (arcana) might notice an odd pattern in the gems, or might feel a faint magical stirring in the room. A successful Scry check (DC 15) allows a character to notice that he is being magically scanned, but he cannot discern the nature of the effect. Disabling the trap is a matter of smashing the appropriate gems in order to disturb the matrix. Of course, during each round that this is going on, the trap still functions.

The Grove of Woodland Insight is a similar concept, but placed, as the name implies, in a woodland grove. The gems are hidden carefully among the trees and the watcher is usually stationed nearby. This setup is popular among elves, fey, and other woodland races, but evil humanoid races sometimes produce wizards or sorcerers, and they can build this spy station as well. Since a grove cannot delay a party the way a locked room can, this trap is usually built in a place ideally suited for a quick rest stop. In the case of benign races, an emissary may be sent out to meet the party in the grove and keep them engaged long enough for the scan to be completed.

## RUBY FLOWER

**Trap Type:** Explosive Trap  
**Construction Type:** Complex mechanical  
**Activation Type:** Instant  
**Trigger:** Local; switch  
**Mechanism:** Chemical  
**Effect:** Injury  
**Attack Bonus:** No attack roll necessary  
**Damage:** 2d6  
**Save:** Reflex save (DC 18) avoids  
**Search DC:** 21  
**Disable Device DC:** 21  
**Challenge Rating:** 1  
**Construction Time/Cost:** 1 week; 1,000 gp

Using two relatively inert chemicals that explode when mixed, the Ruby Flower is a trap particularly suited for use outdoors. The lid of the trap is strong enough so that it breaks only when something at least as great as a human's weight presses against it. The lid then breaks, causing the contents to mix and explode upward. Most animals are unable to trigger it due to their small size. Some traps are specifically designed for the step of a horse, which is

useful if friendly forces have no horses and potential invaders do.

The design of this trap is fairly simple. The switch is a metal rod with side flanges. Ceramic lids are baked onto the flanges. Ceramic pots are then filled with the first chemical. The containers are set under the lids and lashed tight, at which time a sealant is applied to the pottery. This whole assembly is then lowered and rotated into a lead-lined box with bars extending from the corners. The bars then rest under the containers, supporting them and suspending the assembly within the box. The box is filled with the second chemical, then the lid is attached and sealed. The device is then ready, and may be buried wherever desired.

When someone breaks the lid, it drives the central rod down, along with the flanges. This action squeezes the ceramic containers between the flanges and the crossbars, shattering them and mixing the chemicals quickly. The resultant reaction explodes upward. Though the chemicals cause some harm, the projected debris of the lid and box deals the primary damage.

After two years in the ground, the trap has a good chance of failing. Water leaches the lead from the container, letting the second chemical drain away.

The trap is normally not hard to pick out; a suspicious dip in a road's surface or a strange square panel in the floor can be telltale signs. The Ruby Flower is much more effective when placed along natural trails by a character with Wilderness Lore, as per the outdoor trap rules.

Disarming the Ruby Flower can be as simple as placing a flat, unyielding plate over the trap. With some flat stones as legs, a basic bridge circumvents the trap. Alternately, the lid of the box can be carefully pried off and the entire trap disassembled. A character may simply leave a visible marker or flag to warn others of the danger.

This trap sees significant use in warfare. While relatively expensive for killing a single soldier, the demoralization of random deaths of this nature can be quite significant. To this end, they are usually planted in roads, particularly if designed to be triggered only by



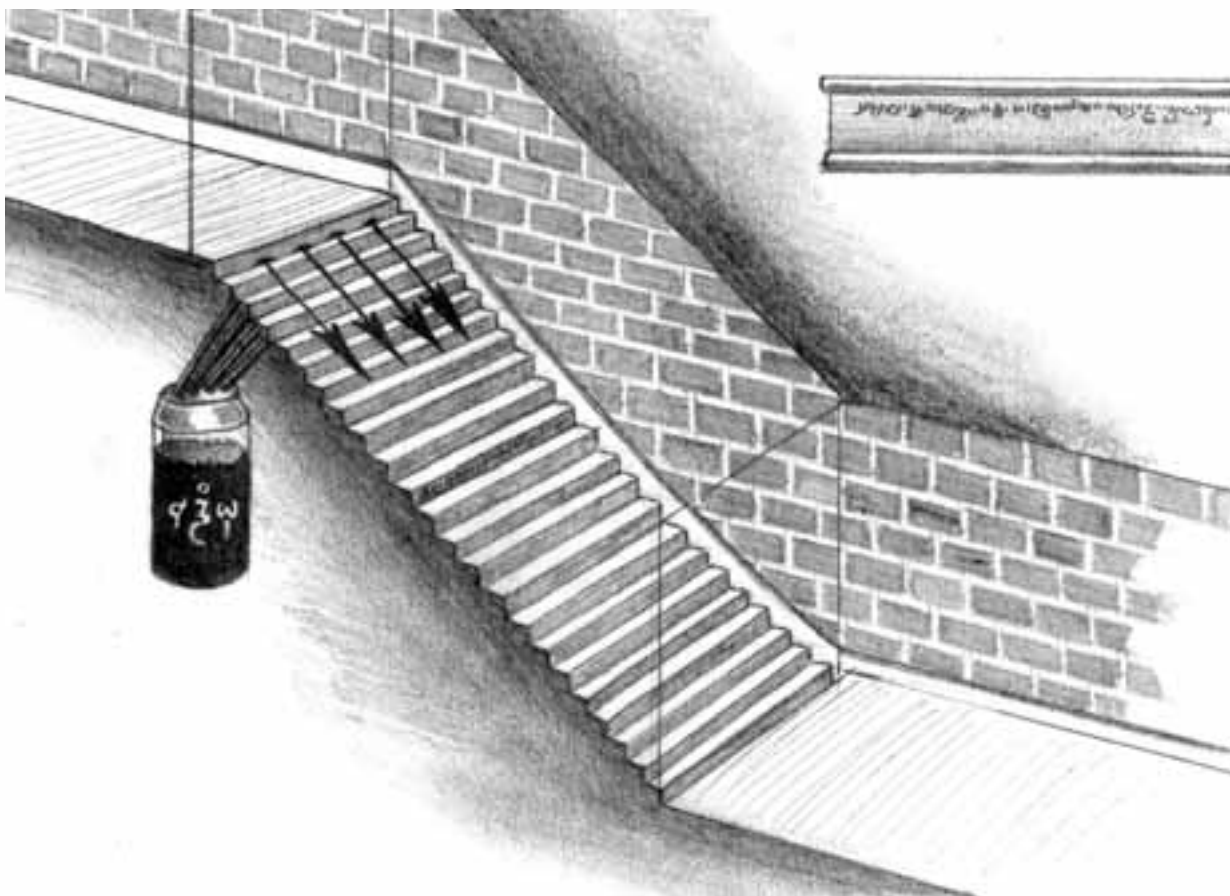

horses. There are more deadly versions, some using elaborate designs to spread the explosion (2d6 to everyone within 5 feet, CR 2; 2d6 to everyone within 20 feet, CR 4).

## SLIPPERY STAIRS

**Trap Type:** Stair Trap  
**Construction Type:** Simple mechanical, magic  
**Activation Type:** Instant  
**Trigger:** Local; magic  
**Mechanism:** Magic  
**Effect:** Hindrance  
**Attack Bonus:** No attack roll necessary  
**Damage:** See below  
**Save:** Reflex save (DC 18) avoids  
**Search DC:** 26  
**Disable Device DC:** 26  
**Challenge Rating:** 1  
**Construction Time/Cost:** 1 day; 1,000 gp; 20 XP

The Slippery Stairs trap sends a wave of slick oil down a flight of stairs to slip up and wash away anyone who triggers it. This trap works best on a staircase of at least 30 or more stairs with few handholds or railings. Setting up a nasty surprise at the bottom of the stairs

such as a trap door or empty suits of armor with weapons pointed upwards increases the deadliness of the Slippery Stairs.

The trigger is magical and activates when someone treads upon a specific stair designated by the trap's creator. Usually this trapped stair is situated halfway up the staircase for maximum effect. If the trapped stair is within 5 feet of the staircase top, a successful Reflex save not only avoids the trap, but also allows a victim to reach the top untouched. Otherwise, a successful saving throw implies that the victim has run down the stairs and gotten off in time or grabbed a handhold such as a railing to avoid being swept away.

The flow of oil follows the staircase regardless of design but must always travel with gravity. It cannot go uphill. At the bottom of the stairs, the oil abruptly stops flowing and leaves a slick residue that remains for 15 minutes before it magically dissolves.

A character who wishes to traverse the slick stairs must make a Climb check (DC 20) and a Reflex save (DC 20). Anyone on the stairs that manages to grab a handhold does not have to

make the Climb check. Victims of this trap take 1d6 points of damage for every 10 feet fallen. A Tumble check (DC 18) halves the damage taken in this manner.

The oil is magical and does not stain. It dissipates when removed from the stairs, so a character cannot collect any in a flask. Once the oil completely dissolves, the trap resets itself and can be triggered again.

## SPRAYED SURPRISE

**Trap Type:** Incapacitation Trap  
**Construction Type:** Magic  
**Activation Type:** Instant  
**Trigger:** Local; magic  
**Mechanism:** Magic  
**Effect:** Hindrance, identification  
**Attack Bonus:** No attack roll necessary  
**Damage:** None  
**Save:** Will save (DC 11) negates  
**Search DC:** 26  
**Disable Device DC:** 26  
**Challenge Rating:** 1  
**Construction Time/Cost:** 1 day; 500 gp; 20 XP

The intent of this trap is to disable potential intruders while not hurting them in any permanent sense. It is combined with an alarm, so that guards can subdue any remaining characters. Once bound, the characters can be interrogated, jailed, or whatever is appropriate. Less scrupulous types simply prefer the tactical advantage this trap gives them if sprung immediately before combat; those who escape the effects of the trap can be targeted first, and then the other intruders dispatched.

This spell trap is normally placed on a door at the head of a corridor. The placement ensures that the intruders are lined up within the spell effect. It casts *color spray* in a cone and sounds an alert for nearby guards. The trigger of the spell is based on darkvision, so invisibility or magical darkness can confound it. A key is usually set up, and the trap deactivates for 10 seconds when someone presents a badge with the key symbol.

Designs threaded into the surface of the door are, to a trained eye, clear indications of magic. A few simple applications with a chisel can destroy the trap and its magic trigger.

## THE FALSE DOOR

**Trap Type:** Door Trap  
**Construction Type:** Simple mechanical  
**Activation Type:** Instant  
**Trigger:** Local; spring  
**Mechanism:** Chemical  
**Effect:** Injury, hindrance  
**Attack Bonus:** No attack roll necessary  
**Damage:** 2d6  
**Save:** Reflex save (DC 20) partial  
**Search DC:** 20  
**Disable Device DC:** 20  
**Challenge Rating:** 1  
**Construction Time/Cost:** 1 day; 1,200 gp

The False Door trap is a simple mechanical trap used to teach unfamiliar visitors the dangers of snooping. It consists of a single oak door with nothing but a solid wall behind it. Some false doors are armed with a small explosive trap that deals 2d6 points of fire damage to anyone within 5 feet of the door when it is opened. Other false doors are sealed so that no amount of force will open it, confusing door-breakers to no end.

The explosive trap consists of two vials of chemicals, one on top of the other. When the door opens more than an inch, the top vial pours its contents into the second vial causing a chemical explosion. In addition to the simple explosive trap, the false door can be equipped with almost any other door trap available, although this will adjust the cost and time of construction accordingly.

The benefits of investing in a False Door trap are twofold: the costs and time involved are small and it is hard to accidentally set the trap off. Since the door doesn't go anywhere, the owner has no reason to ever touch it. Particularly clever trapmakers will install secret doors behind these false doors, expecting trespassers to overlook them in frustration after setting off a trap.

## THE GOOD SAMARITAN

**Trap Type:** Poison Trap  
**Construction Type:** Magic  
**Activation Type:** Instant  
**Trigger:** Local; creature  
**Mechanism:** Magic  
**Effect:** Injury  
**Attack Bonus:** No attack roll necessary

**Damage:** None  
**Save:** Fortitude save (DC 16) resists  
**Search DC:** 25  
**Disable Device DC:** 25  
**Challenge Rating:** 1  
**Construction Time/Cost:** 1 day; 60 gp; 10 XP

A favorite among goblins, the Good Samaritan tricks travelers into handling a deadly viper, a frayed lizard, or some other poisonous creature. The goblins first find the appropriate creature, tie it to a hunter's trap, cover it with the illusion of a harmless animal, and wait for a kindly individual to try to free it. Victims are often too surprised to even realize what has happened before the poison kills them.

Goblins often set this trap near a road or other well-traveled area. They hammer a spike into the ground and attach the poisonous animal with a rope or wire leash. Snakes require a metal clamp. Next, the goblin shaman casts an illusion on the deadly animal, making it look like a fox, rabbit, raccoon, fawn, dog, cat, or similar creature. The illusion creates the image and sound of the desired animal but cannot usually falsify a scent.

A passerby merely sees a harmless animal, caught by some cruel hunter and wailing in pain. The poisonous creature attacks anyone who tries to free it. Victims killed by the trap are plundered and then quickly removed from the scene. When the poisonous creature dies of starvation or dehydration, the goblins leave and set up a new trap elsewhere.

### FRAYED LIZARD

**Tiny Animal**  
**Hit Dice:** ½d8 (2 hp)  
**Initiative:** +2 (Dex)  
**Speed:** 20 ft., Climb 20 ft.  
**AC:** 15 (+2 size, +2 Dex, +1 natural)  
**Attacks:** Bite +4 melee  
**Damage:** Bite 1d2-3 + poison  
**Face/Reach:** 2 ft. x 2 ft./0 ft.  
**Special Attacks:** Poison  
**Special Qualities:** Low-light vision  
**Saves:** Fort +2, Ref +4, Will +0  
**Abilities:** Str 5, Dex 14, Con 10, Int 2, Wis 6, Cha 8  
**Skills:** Climb +8, Hide +6, Move Silently +4, Spot +8  
**Feats:** Weapon Finesse (bite)

**Climate/Terrain:** Forest  
**Organization:** Solitary  
**Challenge Rating:** 1  
**Treasure:** None  
**Alignment:** Neutral

**Poison (Ex):** The bite of the frayed lizard inflicts a deadly poison that deals 1 point of temporary Constitution damage each round until the subject dies. A Fortitude save (DC 12) resists the poison.

## TURN THE INVADER

**Trap Type:** Charm Trap  
**Construction Type:** Magic  
**Activation Type:** Instant  
**Trigger:** Local; magic  
**Mechanism:** Magic  
**Effect:** Hindrance  
**Attack Bonus:** No attack roll necessary  
**Damage:** None  
**Save:** Will save (DC 12) negates  
**Search DC:** 26  
**Disable Device DC:** 26  
**Challenge Rating:** 1  
**Construction Time/Cost:** 1 day; 500 gp; 20 XP

This is a favorite trap of enchantment sorcery guilds, one they are paid well to place in other guildhalls. It is effective in catching burglars in a rather peaceful way. The spell trap can also be cast on items, and is sometimes used this way as a cheap form of *geas*.

The trap casts *charm person* when touched. The target feels an obligation and allegiance to the owners of the building. The effect may not be immediately obvious. If the target is infiltrating, either by guile or moving unseen, she will alert guards and try to turn herself and any companions in to the authorities. The charmed character will be smart about it, however, and choose a good opportunity. The trap has 50 charges, so it is quite possible that a large group can be affected.

A guard or visitor who activates the trap may not be noticeably affected. In several halls, guildmasters have their guards walk through these traps on occasion, as a cheap way of testing loyalty. New guards will typically own up to cheating at cards or other minor infractions. Guards soon learn to keep their relations with the guild proper, or become experienced

enough to resist the magic.

The trap is pretty easy to spot and identify. The symbols are intended to blend into the patterns of the flooring, but the colors and precision of lines are somewhat obvious. Rubbing several of the lines with a metal implement disables the spell trap and the magic trigger.

## ALCOVES

**Trap Type:** Chute and Slide Trap  
**Construction Type:** Simple mechanical  
**Activation Type:** Instant  
**Trigger:** Local; counterweights  
**Mechanism:** Counterweights  
**Effect:** Ensnarement, injury  
**Attack Bonus:** No attack roll necessary  
**Damage:** 1d3  
**Save:** Reflex save (DC 25) avoids  
**Search DC:** 20  
**Disable Device DC:** 21  
**Challenge Rating:** 2  
**Construction Time/Cost:** 2 weeks;  
2,000 gp

Alcoves is a mechanical trap with an illusionary component to fool adventurers into triggering it and a monster component to deal damage.

This trap is placed in a straight corridor as it approaches a T-junction or an intersection. Sixty feet from the intersection are two alcoves, one on either side of the corridor. If any creature comes within 5 feet of the alcoves, an illusion is created at the intersection depicting two bow-wielding gnolls shouting in their native language.

The actual trap is hidden in the alcoves, and moving into either alcove causes the trap to be sprung. The rear wall of the alcove falls backward and the floor pivots upward. The counterweights that cause the trap to spring are sensitive, so anything over 20 lb. triggers the trap.

The victim slides down a slick, 10-ft.-long chute and into a chamber 15 ft. square. The fall causes only 1d3 subdual damage as the chamber contains foul and murky water to a depth of three feet. Once the victim is in the chamber, two zombies (MM 191) rise from the water and attack until destroyed.

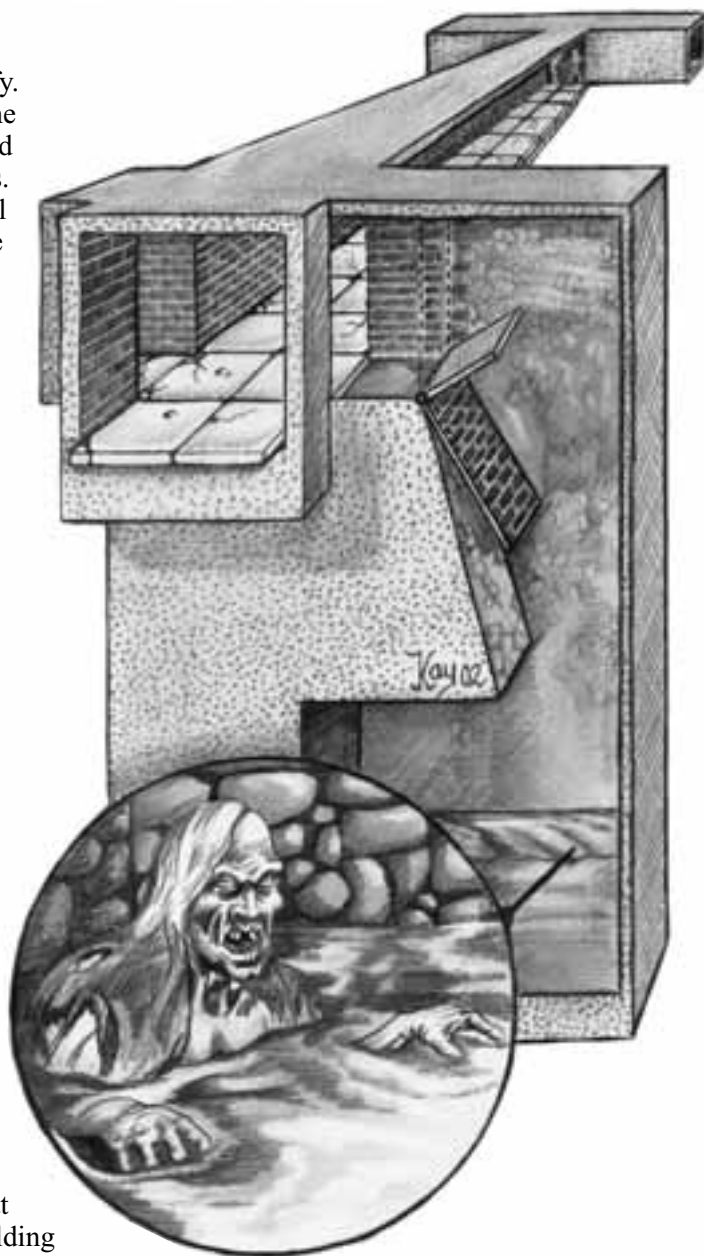

The chute is quite slick, and requires a successful Climb check (DC 25) to negotiate. The alcove wall is easy to open, but only from the outside. Trapped characters cannot open the pivoting wall from their side. With help from the other side, escape is quite easy, as one person can hold the trap open and lower a rope to any victims.

## COLLAPSING LADDER

**Trap Type:** Pit Trap  
**Construction Type:** Simple mechanical  
**Activation Type:** Instant  
**Trigger:** Local; switch  
**Mechanism:** Gravity, gear  
**Effect:** Injury  
**Attack Bonus:** No attack roll necessary  
**Damage:** 4d6  
**Save:** Reflex save (DC 22) avoids  
**Search DC:** 20  
**Disable Device DC:** 20  
**Challenge Rating:** 2  
**Construction Time/Cost:** 2 weeks; 2,000 gp

The Collapsing Ladder trap is meant to injure unsuspecting adventurers. The trap is in the guise of a 15-ft.-tall ladder leading up to a simple wooden trapdoor in the ceiling of an alcove.

The ladder itself is iron and quite sturdy; it is attached to the wall by thick metal rods. A rung 12 feet up the ladder is the trigger. Pulling that particular rung acts as a lever, which pulls on a steel pole running behind the wall. The steel pole holds the floor beneath the ladder and the rods that secure the ladder in place. The rung moves down slightly, triggering the release mechanism and prying the steel pole back and away from the ladder.

The floor beneath the ladder drops out while the ladder is released from the wall, dropping the ladder and any person on it into the 40-ft.-deep pit. Characters on the ladder can make a Reflex save (DC 22) to jump off and away from the pit before falling. Those who fail suffer 4d6 points of falling damage.

The trap is difficult to detect because of the cleverly disguised rung. Disabling the Collapsing Ladder involves propping up the lever rung so that when pressure is placed on it the rung does not release and trigger the trap. Careful characters can also merely avoid the trapped rung, assuming the first climber spotted the deception.

## FLASHBLIND

**Trap Type:** Item Trap  
**Construction Type:** Complex mechanical  
**Activation Type:** Instant  
**Trigger:** Local; switch  
**Mechanism:** Counterweight, gear  
**Effect:** Hindrance  
**Attack Bonus:** No attack roll necessary  
**Damage:** None  
**Save:** Reflex save (DC 21) avoids  
**Search DC:** 21  
**Disable Device DC:** 21  
**Challenge Rating:** 2  
**Construction Time/Cost:** 2 weeks; 2,000 gp

This trap sprays a fine magnesium powder and then ignites it, causing an intense flash of light and heat. The heat is enough to singe and possibly ignite paper within a foot or so of the trap. Also, anyone looking in the general vicinity of the trap must make a Reflex save (DC 21) or be blinded for 1d3 minutes.

Flashblind is a popular trap for chests, but it can be arranged for other containers or even doors. Item versions are usually one-shot traps, while those in more elaborate arrangements may work multiple times. In the latter case, Flashblind traps require a great deal of work to keep in proper working order.

The simple form of Flashblind is relatively easy to notice and disarm. A hook set near the locking mechanism of the trapped item triggers the trap. When the lock is opened properly, it blocks the hook. Otherwise the hook is free to drop when the chest opens. This motion engages gears near the hinge on the lid. Opening the lid now releases a counterweight, which drives the trap mechanism to fling out powder and sparks.

Noticing and pinning the hook in place can disarm this whole system. Another method is to simply turn the chest on its back and carefully open it. This prevents the counterweight from exerting any force. Item versions of the trap often use springs, and are not as vulnerable.

Combined with an alarm or placed near a pressure plate, Flashblind can lay the groundwork for more deadly responses such as guardian monsters.

# HALL OF DAGGERS

- Trap Type:** Animated Blade Trap  
**Construction Type:** Simple mechanical, magic  
**Activation Type:** Instant  
**Trigger:** Local; switch  
**Mechanism:** Counterweight  
**Effect:** Identification  
**Attack Bonus:** No attack roll necessary  
**Damage:** None  
**Save:** None  
**Search DC:** 20  
**Disable Device DC:** 20  
**Challenge Rating:** 2  
**Construction Time/Cost:** 2 weeks; 2,000 gp

Hall of Daggers is a simple trap that makes full use of sealed-trigger mechanisms and several silos of animated knives designed to attack curious trespassers.

This trap appears as an intersection in a network of passages or tunnels. The ceiling of the intersection is typically several feet higher than that of the connecting passages. This higher ceiling is supported by four large pillars, with one pillar placed in each corner of the intersec-

tion chamber. The pillars themselves serve no structural purpose and are merely storage silos for the 4d6 animated daggers.

A character who attempts to open one (or all if the DM chooses) of the chamber doors a series of counterweights activates to open several concealed trapdoors within the chamber's support pillars. As mentioned, once the pillars have opened, 4d6 animated flying daggers spring forth to attack any characters within the chamber and connecting halls. The daggers do not stop until destroyed or otherwise incapacitated. The daggers are treated as Small animated objects (MM 17) and possess a flying speed of 60 ft.

Several popular variations on this trap are the additional use of other "lock-based" traps to foil escape attempts and the use of several pit traps, as fleeing characters more easily overlook secondary hazards.

An especially curious or cautious rogue may notice the faint crevices created by the trapdoors carved within each of the pillars. Other warning signs may be traces of dried blood on the chamber walls or pillars. To disarm the trap, a rogue must jam the individual trapdoors on each pillar.

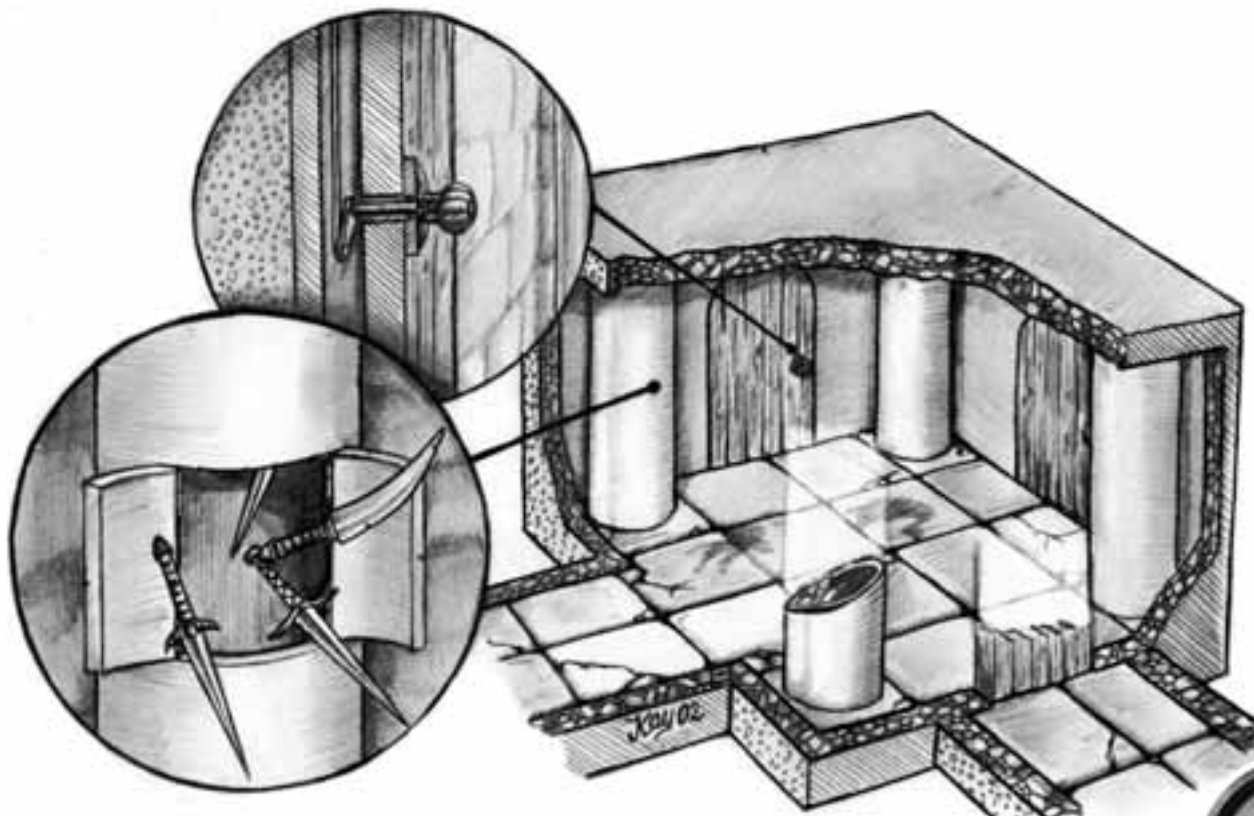

## HIDDEN DOOR MISDIRECTION

**Trap Type:** Pit Trap  
**Construction Type:** Complex mechanical  
**Activation Type:** Instant  
**Trigger:** Local; switch, trapdoor  
**Mechanism:** Gears, gravity  
**Effect:** Ensnarement, injury  
**Attack Bonus:** No attack roll necessary  
**Damage:** 2d6  
**Save:** Reflex save (DC 20) avoids  
**Search DC:** 21  
**Disable Device DC:** 25  
**Challenge Rating:** 2  
**Construction Time/Cost:** 2 weeks; 2,000 gp

This trap consists of a featureless stone door to the left of two levers. Each lever is in the up position, and has five marked positions.

Above the levers is engraved the following message:

“There is both a key and a door. The levers are neither.”

If the levers are moved at all, a trapdoor opens, requiring a Reflex save (DC 20) to avoid falling into a 20-ft. deep pit. The 10 ft. by 5 ft. trapdoor is placed right below the levers. It shuts one round after opening, making egress more difficult. Once the door is opened again, climbing out of the pit requires a successful Climb check (DC 20) as the walls are quite smooth.

The solution to the trap is to press against the door, causing it to depress to a depth of two inches before locking into place with an audible click. Doing so requires a successful Strength check (DC 14). At this point, moving the levers in any way causes the wall section of the levers to slide in, revealing an archway. Moving either lever in the space beyond resets the wall and mechanisms.

Searching can be done on the area, the levers, and the door. A successful search of the wall or the area around it detects the outlines of the trapdoor. Searching the wall may reveal that it might be moveable, from the scoring and suspicious gaps in the wall. The door is the most revealing, as a rogue will recognize attributes similar to pressure plates, based on the simple construction and a slight give to the door.

The trap is easy to disarm by wedging the trapdoor closed. Since the trapdoor does not activate unless the levers are moved, there is no danger of the trap activating while a disarm attempt is underway.

The Hidden Door Misdirection, as a somewhat complex door trap, is suited for a variety of purposes. It is not quite deadly, although the pit could be filled with monsters of some kind. The mechanism requires a manual reset after 15 uses, as well as periodic maintenance to keep the panels moving smoothly.

## JUMP TRICK

**Trap Type:** Invisible Wall  
**Construction Type:** Magic  
**Activation Type:** Instant  
**Trigger:** Local; magic  
**Mechanism:** Magic  
**Effect:** Injury, hindrance  
**Attack Bonus:** No attack roll necessary  
**Damage:** See below  
**Save:** None  
**Search DC:** 30  
**Disable Device DC:** 30  
**Challenge Rating:** 2  
**Construction Time/Cost:** 10 days; 10,000 gp; 400 XP

This is a relatively simple magic trap. On the floor is a *permanent image* depicting a 20 ft. by 20 ft. by 50 ft. deep pit, with what appears to be the broken remains of a bridge that once extended across. The gap of the bridge appears to be about 8 feet across. A *wall of force* blocks the corridor just in front of the pit. The fact that such walls are invisible is key to this trap.

Characters attempting to jump across the gap in the bridge are in for a big surprise, slamming into the *wall of force* and taking 1d3 points of subdual damage per 5 feet indicated on the Jump check.

Anyone that tests the sturdiness of the bridge feels a nice, solid surface. A rogue searching for traps has a slight chance of noticing the invisible wall by subtle distortions in the air where the *wall of force* blocks the passage. A pebble or other object tossed across the space bounces off the wall, assuming it travels far enough, and stops at floor level even over the pit. This spell cannot be disabled, per se, as the trap simply consists of a pair of permanent spells.

Once identified, it take a powerful spell to actually remove the wall, as *dispel magic* will not affect it. The wall does have a suppression contingency trigger. If someone mutters the word 'alfrazu' within sight of the wall, the wall becomes insubstantial for two rounds. It becomes substantial immediately if the word is repeated, allowing an NPC to run through and evade pursuers. Characters may attempt a Listen check (DC 20), success indicating they hear something muttered. If the check exceeds the DC by 5 or more, the PC hears the specific word used.

A Search check (DC 30) may find the spell trigger. If found, it becomes clear that it is a trigger to deactivate or modify the effect, not a conventional triggered spell. A successful Disable Device check (DC 30) destroys the trigger, but this merely makes the wall harder to bypass rather than bringing it down, since the command word no longer functions.

This trap is suited for a range of levels. It serves as a fairly simple, though expensive, front door to a mage's lair, or to the headquarters of an organization. Higher level parties can simply force their way through, by using divinations to figure out how to get through, or by destroying the *wall of force*. Lower level parties can still do quite well, generally by interrogating NPCs. They could go to a nearby town and gather information on the area, get a former guard drunk, or something similar.

An option more suited for tombs and uninhabited locations is a *one way wall*. The spell trigger in this case is a proximity switch. It allows the PCs in, but when they try to leave, the force blocks them. In this case, low-level parties may be forced to chip around the magic barrier.

### ONE WAY WALL

Evocation [Force]

**Level:** Sor/Wiz 8

**Components:** V, S, M

**Casting Time:** 1 action

**Range:** Close (25 ft. + 5 ft./2 levels)

**Effect:** Wall whose area is up to one 10-ft. square/level or a sphere or hemisphere with a radius of up to 1 ft./level

**Duration:** 1 minute/level

**Saving Throw:** None

**Spell Resistance:** No

This spell is identical to *wall of force*, except that the caster can designate one side of the

wall as passable. In effect, this creates a one-way barrier through which creatures on one side may walk or cast spells freely. The spell is often used to trap intruders in an area, or to create a near-impervious barrier through which a mage can launch attacks at his enemies.

*Arcane Material Component:* One powdered gem of at least 100 gp value.

## LEG SHREDDER

**Trap Type:** Barbed Leg Trap

**Construction Type:** Simple mechanical

**Activation Type:** Instant

**Trigger:** Local; trapdoor

**Mechanism:** Gravity

**Effect:** Ensnarement, injury

**Attack Bonus:** No attack roll necessary

**Damage:** 1d6

**Save:** Reflex save (DC 20) avoids

**Search DC:** 20

**Disable Device DC:** 20

**Challenge Rating:** 2

**Construction Time/Cost:** 2 weeks; 2,000 gp

The Leg Shredder is a trapdoor disguised as a step, which opens into a 24-inch deep compartment lined with flexible metal barbs. Generally built at the midpoint of a stone staircase, the trapdoor blends almost seamlessly among the other steps.

Creatures of small, medium or larger size that step on the trapped stair must succeed at a Reflex save (DC 20) or have one of their legs slip through the trapdoor and become anchored by the downward pointing barbs. A creature stuck in the compartment suffers a -2 penalty to attack rolls, suffers a -4 penalty to effective Dexterity and cannot move. Creatures taking a full-round action to make a Strength or Escape Artist check (DC 20) to pull free from the trap suffer an automatic 1d6 points of damage regardless of success or failure. A successful Disable Device check (DC 20) takes 1d4 rounds to complete and allows a creature to withdraw from the compartment without taking damage.

A successful Search check (DC 20) allows a creature to recognize the step as being a hidden trapdoor. If the Leg Shredder was added into an existing stairway instead of being built into the stairway as it was constructed, the Search DC is only 18 due to variations in



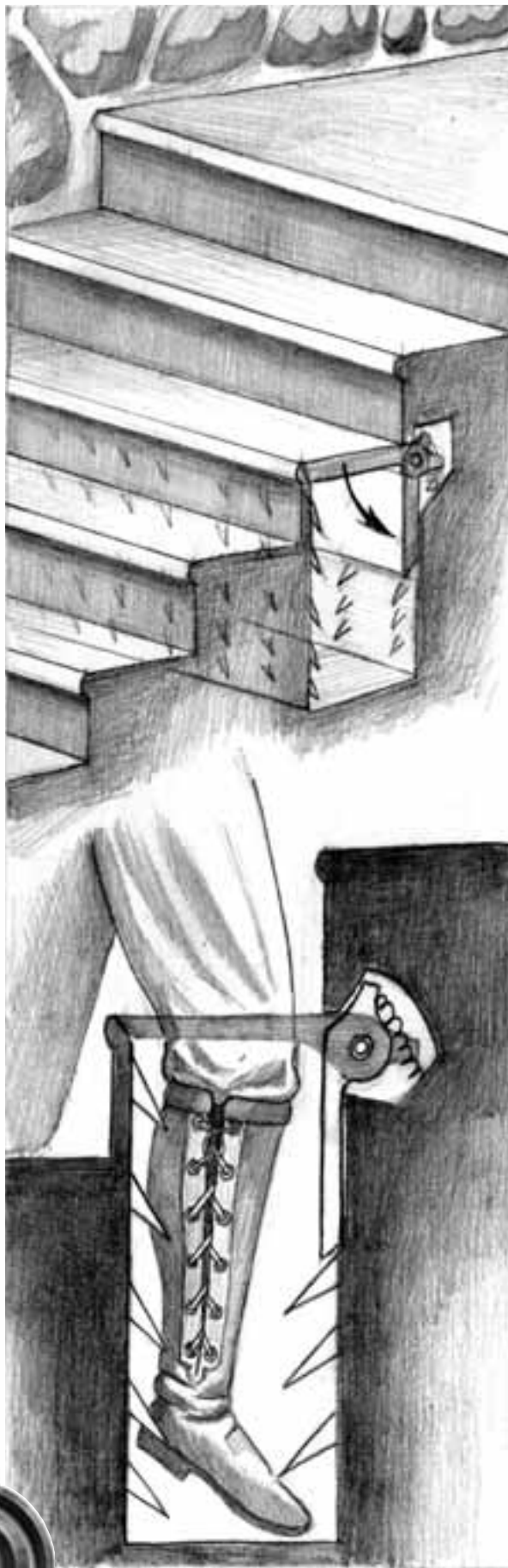

stone color and craftsmanship. Disabling the Leg Shredder is a simple matter of jamming the trapdoor or filling the compartment beneath the step with rubble or garbage.

## PERSONAL DARKNESS

**Trap Type:** Blinding Trap  
**Construction Type:** Magic  
**Activation Type:** Instant  
**Trigger:** Local; magic  
**Mechanism:** Magic  
**Effect:** Hindrance  
**Attack Bonus:** No attack roll necessary  
**Damage:** None  
**Save:** Fortitude save (DC 12) negates  
**Search DC:** 27  
**Disable Device DC:** 27  
**Challenge Rating:** 2  
**Construction Time/Cost:** 1 day; 1,000 gp; 40 XP

This trap is usually crafted as part of a larger design. It is frequently placed midway along a narrow ledge or unstable bridge. Blinding traps of all kinds are popular, as they can have immense tactical and psychological impact on their targets.

The spell trap casts *blindness* on the target. If the save is failed the effect is permanent, requiring magic to cure. One effect of blindness is a  $-4$  penalty to Dexterity-based skills. This becomes quite significant on a narrow ledge or bridge, where Dexterity-based skills are going to be used at least a few times. The CR of the bridge is considered separately from the Personal Darkness trap.

The Personal Darkness spell trap is fairly easy to pick out, as far as magical traps go. The lines and symbols forming it are small but distinct. They are clearly different from natural patterns of stone or wood. Once spotted, the trap can be stepped over with a successful Dexterity check (DC 12). Disarming it requires chiseling two lines into the area of the trap, breaking the spell's magic and ruining the magic trigger.

## SCARLET HOWLER

**Trap Type:** Mark and Alarm Trap  
**Construction Type:** Complex mechanical  
**Activation Type:** Instant  
**Trigger:** Local; light sensor  
**Mechanism:** Chemical

## LIGHT SENSOR TOOLS

Many of the traps in these pages use complex mechanisms that employ light-sensitive materials and light sensors to activate and deactivate their devices. Over the years many devices have been designed to help a rogue overcome these tricky mechanisms. Three such devices are presented below.

**Mirror armature:** This device is a telescoping pole set with a number of small arms and mirrors. It can be adjusted to stretch across up to 12 feet of space, allowing rogues to examine suspicious areas from afar or disable light-based traps more easily. Though it exerts little power, it is designed to minimize vibration and can be adjusted with great precision, as can each of the crosspieces. It can handle up to three separate light trails, assuming they cross within two feet of one another.

The mirror armature can be used to assist in Disable Device checks on traps using light-based switches, giving a rogue a +2 equipment bonus to such checks. It also allows a rogue to examine traps and suspicious areas from afar, meaning that even if she somehow triggers the trap, she might be out of its range of effect.

It requires a Craft (trapmaking) check (DC 22) to make this device. It is hardness 2, hp 5. Note that if the mirror armature takes damage it requires a successful Craft (trapmaking) check (DC 15) to adjust it into working order.

**Cost:** 200 gp; **Weight:** 10 lb.

**Mirror frame:** A much larger version of the armature, the mirror frame consists of four adjustable sides. It functions in much the same way as the smaller version, and still has a reach of 12 feet. However, it can handle up to 10 light trails that do not even approach one another. This is usually overkill, except in regions where light sensors are used quite frequently.

The Craft (trapmaking) check to create the mirror frame is DC 24, and the final product has hardness 2, hp 15. If damaged at all, it requires a Craft (trapmaking) check (DC 18) to get into working order. Unless otherwise noted, it provides the same benefits as the armature.

**Cost:** 800 gp; **Weight:** 30 lb.

**Smoker:** This device is a simple ceramic smudge pot, wrapped in rope to keep it from breaking. By using a slow match and a bit of charred wood, a rogue can create a decent amount of smoke useful for several purposes, from smoking out bees, checking for light sensors, or sending signals. A smoker produces less smoke than a smokestick, but it lasts for up to two hours before needing to be refilled. Additionally, with a little practice, anyone can properly char the wood pieces needed to refuel it (Wilderness Lore check DC 10).

**Cost:** 10 gp; **Weight:** 3 lb.

**Effect:** Identification

**Attack Bonus:** No attack roll necessary

**Damage:** None

**Save:** None

**Search DC:** 21

**Disable Device DC:** 25 (spray nozzle only)

**Challenge Rating:** 2

**Construction Time/Cost:** 2 weeks; 2,110 gp

In many cases, killing anyone who enters the wrong room of your castle is excessive. Curious children or youths, lost servants, and unwise but otherwise harmless villagers being torn to ribbons by deathtraps can be a political nightmare in some societies. The Scarlet

Howler trap generates a loud alert and sprays trespassers with a dye. It is fairly harmless, and even the scarlet dye is only a mild irritant if it gets in the eyes. The mechanism is sophisticated, however.

A *continual flame* is set in one wall. The light shines through a hole in the wall and crosses the space. A material that changes shape due to exposure to light is the heart of a small light sensor in a hole in the opposite wall. Under normal circumstances, the light crosses from one wall to the other, lighting the sensor and keeping it in an off position. If something blocks the light the sensor goes dark, and the switch is engaged.

The first stage of the trap is the mixing of two chemicals. The reaction expands rapidly and is used to propel the scarlet dye out of a sprayer in the ceiling. The escaping gas then goes through a whistle, producing the alarm. The sound draws guards, while the dye makes it clear who triggered the alarm. With a bit of ingenuity, it is also possible to determine what people were up to or where they were standing from the patterns of the ink marks around the room.

The dye sticks to clothing and flesh for a day or two, but is relatively easy to wash off. The trap must be reset with more chemicals and dye after each use. Designing the trap to be automatically reset is difficult, as the dye tends to clog the light sensor after a short time unless it is regularly cleaned.

Experienced thieves wary about light sensors can use fine flour or smoke to look for them. This light system lacks the concave and flat lens combination that more sophisticated mechanisms use. There is a telltale pinpoint of light around the light sensor, a clear indication of its presence. There may also be signs of ink residue. The head of the sprayer in the ceiling is a strong hint as to the nature of the trap.

Once identified, the simplest way of avoiding the trap is crawling under the thread of light. This requires a Dexterity check (DC 16) to perform without triggering the trap.

Actually disabling the trap is impossible without either a mirror armature (see sidebar) or inventive use of magic. The sprayer is difficult to jam properly, and difficult to access without tripping a switch. In addition, there is no way for an observer to know about the alert noise. Even if the nozzle is disabled, activating the trap still produces the alert.

The trap as presented is a rather high-end version of the mechanism. Though traps like this are not dangerous, they can be vital in protecting secure areas. Given the difficulty of acquiring light sensors, pressure plate versions are also common (Search check DC 22, Disable Device check DC 23, CR 3). Those uninterested in avoiding bloodshed may substitute poison or acid for the dye, making a particularly deadly trap (CR 4+).

## SLIDE ROOM

**Trap Type:** Slide Trap  
**Construction Type:** Complex mechanical  
**Activation Type:** Instant  
**Trigger:** Local; trapdoor  
**Mechanism:** Counterweights  
**Effect:** Injury  
**Attack Bonus:** See below  
**Damage:** See below  
**Save:** Reflex save (DC 20) avoids  
**Search DC:** 21  
**Disable Device DC:** 21  
**Challenge Rating:** 2 or 6  
**Construction Time/Cost:** 2 weeks; 2,000 gp or 6 weeks; 6,000 gp

Slide Room is a simple trap that takes advantage of an unprepared or inattentive party by providing an ordinary scene to hide its dangers.

A Slide Room appears to be a simple bedroom, and is most effective when placed near other such rooms in a dungeon or castle so as to hide its true purpose. Simple furnishings fill the room, though all sit against the walls.

The trap is sprung as soon as a creature weighing at least 100 lb. steps halfway into the room. Once this happens, the floor tilts forward rapidly due to the counterweights underneath the room. The pivot point is along the wall where the PCs entered. The room's furnishings, however, do not fall because they are bolted to the walls.

PCs at least halfway into the room must make a Reflex save (DC 20) to avoid sliding into the waiting pit. The DC is reduced to 15 for those less than halfway into the room.

There are two variations of the Slide Room trap: a 20-ft.-deep spike trap (CR 2) and a shallow acid pit (CR 6). The spiked pit deals 2d6 points of damage for the fall and the character falls on 1d4 spikes, each having a +10 melee attack bonus and dealing 1d4+2 points of damage. Being immersed in acid deals 10d6 points of damage per round.

The floor springs back up after 1d4 rounds, resetting itself and trapping characters in the pit. A short ledge rings the pit, allowing those who fall in to climb out fairly easily (Climb check DC 15). However, they must still find a way to lower the floor before they can escape.

Observant adventurers can detect the trap because the furniture is not flush against the floor. Disabling the trap is difficult, though, because all of the moving parts are below the room.

## SEEPER TRAP

**Trap Type:** Item Trap  
**Construction Type:** Simple mechanical  
**Activation Type:** Extended  
**Trigger:** Local; heat activated  
**Mechanism:** Spring  
**Effect:** Injury, hindrance  
**Attack Bonus:** No attack roll necessary  
**Damage:** Fatigued  
**Save:** Fortitude save (DC 17) resists  
**Search DC:** 25  
**Disable Device DC:** 20  
**Challenge Rating:** 2  
**Construction Time/Cost:** 2 weeks; 2,000 gp

This ingenious trap employs a rather basic design. The handle of a sword or other weapon is crafted with small gaps and spaces within. These spaces have a poison-laden wax carefully worked into them. To all appearances, it looks to be an elegantly crafted wooden handle.

Thereafter, anyone using the item for more than one round warms the wax sufficiently to cause the poison to seep out of the wood and into the hand that wields it. This process is nearly undetectable, requiring a Spot check (DC 25) by the wielder to notice.

A leather gauntlet or wrapping over the grip will slow the seeping of the poison to four rounds of combat. But once soaked into the gauntlet or wrapping, the poison takes effect within a round of further use.

The trap is detectable in the unusual construction of the grip. A character taking time to examine it carefully may suspect something is

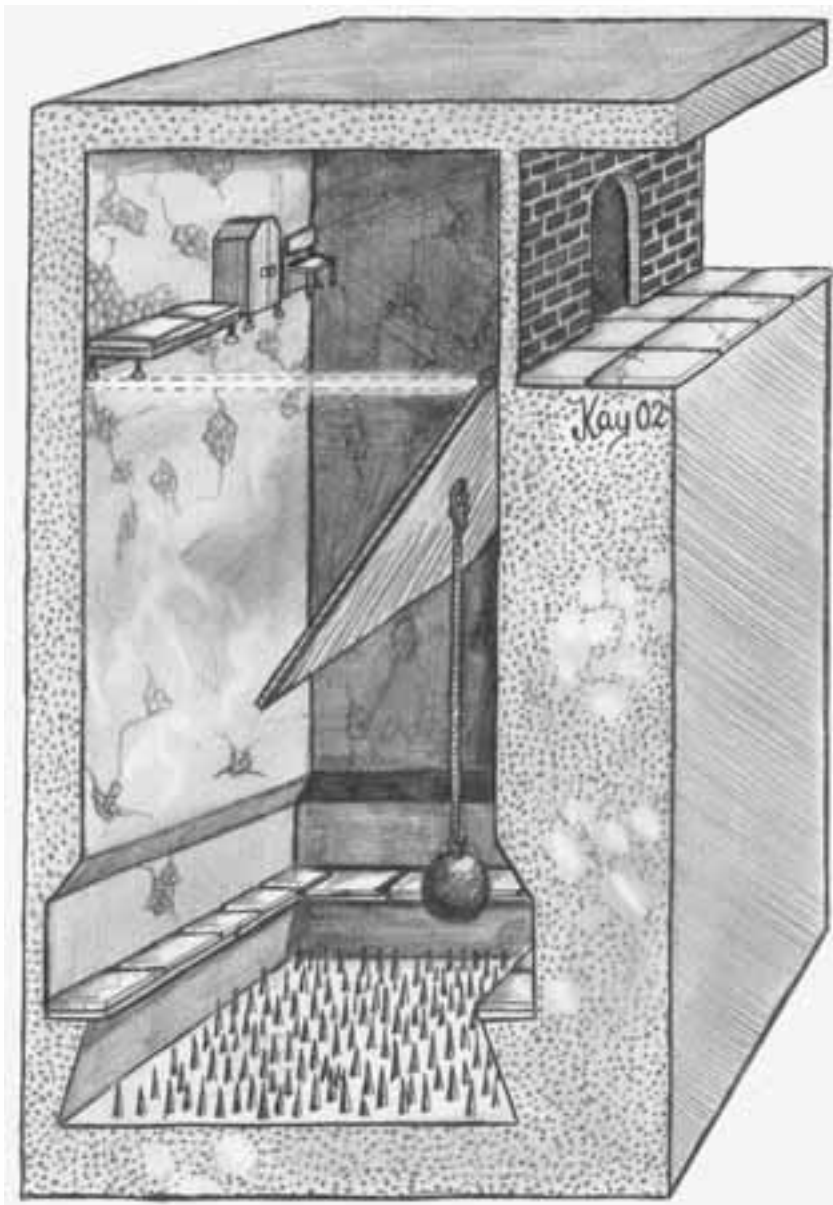

up, as the wood appears oiled or waxed more than one would normally expect.

Disarming the trap is rather easy. The grip can be replaced, or heat can be carefully applied to drain all the wax from the wood.

Alternately, the grip can be sealed under either a coating, more wood, or well-designed leather wrappings. These are a bit more difficult to pull off than merely melting the wax from the wood, and may require a Craft (weapon-smithing) check (DC 20) to perform.

The save listed is for bearmad poison, but any contact poison can be substituted.

## Glyph Eggs

*Glyph eggs* are inexpensive spheres that release arcane or divine spells when shattered. They are covered in detail in Fantasy Flight Games' *Spells & Spellcraft*.

The advantage of the Snap Trap over hiring a mage to imbue a trap with magic is flexibility. A trap's effect may be altered (rendered more or less deadly or to deliver a different brand of inconvenience) merely by exchanging one egg type for another. Some devious trap maintainers may even vary a specific trap's effect from one encounter to the next, which could take characters by surprise.

For those who do not have access to *Spells & Spellcraft*, a few sample *glyph eggs* are presented below. Use the attendant CRs for determining the appropriateness of the trap and add the price of the egg to the trap price.

Spell Effect	CR	Price
<i>Shatter</i> (area affect only)	2	300 gp
<i>Sound Burst</i>	2	300 gp
<i>Web</i>	2	300 gp
<i>Fireball</i>	3	750 gp
<i>Spike Growth</i>	3	750 gp
<i>Stinking Cloud</i>	3	750 gp

## SNAP TRAP

**Trap Type:** Glyph Egg Trap  
**Construction Type:** Complex mechanical  
**Activation Type:** Instant  
**Trigger:** Local; switch  
**Mechanism:** Spring  
**Effect:** Varies  
**Attack Bonus:** No attack roll necessary  
**Damage:** Varies  
**Save:** Varies  
**Search DC:** 21  
**Disable Device DC:** 25  
**Challenge Rating:** See the "Glyph Eggs" sidebar  
**Construction Time/Cost:** 2 weeks; 2,000 gp

Building protective traps into chests and strongboxes is an expensive process requiring the services of skilled specialists. For those desiring a less costly alternative to a custom-built mechanical trap or hiring someone to cast a *fire trap* spell, and for those who may wish to transfer traps from one enclosure to another from time to time, the Snap Trap is a viable solution.

The Snap Trap is a powerful mousetrap-like device set in a metal frame that may be adjusted to fit snugly within the lids of rectangular chests of up to three feet in diameter. Once

installed, the trap may be armed by placing a *glyph egg* (see sidebar) in the receptacle and winding the spring that powers the drive bar. Closing the lid sets the trap.

There is no way of detecting a Snap Trap by examining the outer surfaces of the chest, making it a subtle trap for those unfamiliar with such designs. It may be possible to detect a suspicious weight in the chest's lid by manipulating it, but this is difficult to do with heavy chests and in any case won't reveal the nature of the trap.

Adding to the trap's utility, physically disarming the trap is nearly impossible since opening the lid more than a hair's width sets it off. Extremely skilled thieves may be able to run wires into the innards of the chest and knock the egg out of its socket, but those capable of such feats are rare. Those in the know may safely open the chest by uttering the egg's command word, which renders it inert. The egg is still lost when the trap goes off, but no harm comes to the opener.

## Sticky Situation

**Trap Type:** False Floor and Alchemical Glue

**Construction Type:** Simple mechanical

**Activation Type:** Instant

**Trigger:** Local; pressure plate

**Mechanism:** Gravity

**Effect:** Ensnarement; alarm

**Attack Bonus:** +12 melee

**Damage:** None

**Save:** Reflex save (DC 20) to avoid

**Search DC:** 20

**Disable Device DC:** 20

**Challenge Rating:** 2

**Construction Time/Cost:** 2 weeks; 2,000 gp

This is a very basic trap, one that is easily constructed even by technically inept beings. Since the trap is not directly lethal, it is very suitable for low-level adventurers. It consists of a fairly small pit, perhaps a foot deep or so, dug into a section of corridor (usually a 5 ft. by 5 ft. square), and covered with a weakened layer of the same material used as flooring elsewhere in the corridor. The pit is then filled with alchemical glue very similar to that used in tanglefoot bags (PHB 114). The underside of the covering is lined with tiny bells.

When a person walks across the covering, it breaks, causing the trespasser to become stuck in the glue while the bells ring to alert nearby guards or monsters to the intruder. In some cases, this will cause guards to be summoned to deal with the interlopers; in others, wild beasts will be unleashed to run down the corridor. In some cases the guards might just line up 20 feet away from the victim and engage in a little target practice.

If the trap location has been abandoned for a while, then new inhabitants might have learned about the gluepit and set it up for their own use. It is possible that a particularly strong or potent creature might react to the chime, causing some interesting tension as the players attempt to free a stuck comrade while they hear something large and dangerous lumbering towards them.

A rogue may spot a slight discoloration or gap where the weaker floorboards join the strong ones. Small gobs of dried glue may be seen on the walls near the trap. There may be a distinctive, but faint, odor to the glue that a trained rogue can detect.

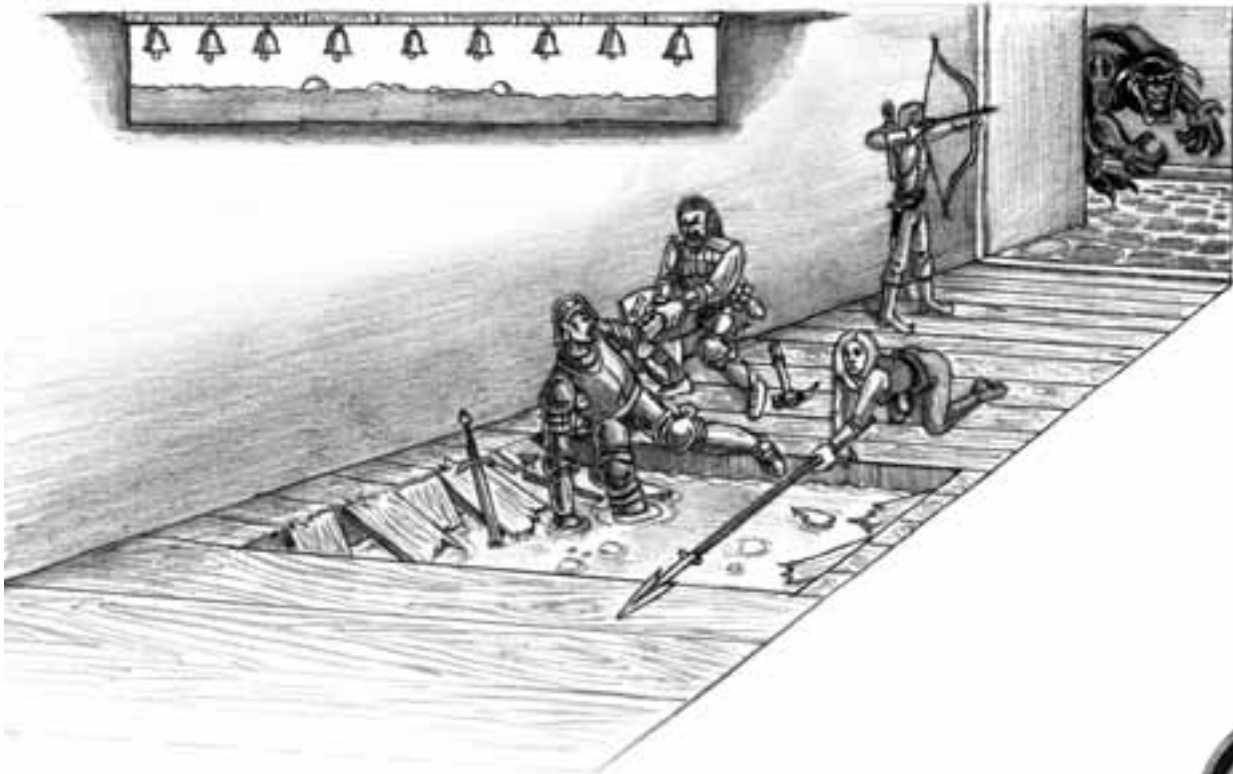

## THE CRYPT

---

**Trap Type:** Monster Trap  
**Construction Type:** Simple mechanical  
**Activation Type:** Extended  
**Trigger:** Local; switch  
**Mechanism:** Gravity  
**Effect:** Identification  
**Attack Bonus:** No attack roll necessary  
**Damage:** None  
**Save:** Reflex save (DC 22) avoids  
**Search DC:** 24  
**Disable Device DC:** 20  
**Challenge Rating:** 2  
**Construction Time/Cost:** 2 weeks; 2,000 gp

The Crypt is one of the numerous, even classic, traps that utilizes the simple elements of hidden compartments, tripwires, and monsters to injure trespassers or the overly curious.

The Crypt (or variations of such) may be found in all manners of dungeon complexes, strongholds, castles, or subterranean networks. In most cases, the trap is placed within a well-worn hall or passage. The passage may be any size the builder chooses, but with the nature of the mummies' effectiveness depending on close-quarters combat, a smaller, more narrow passage is preferred.

The first step of this trap is activated when a character breaks the tripwire that extends across the length of the passage. A successful Reflex save (DC 16) allows a character to avoid the tripwire without breaking it, as long as he noticed it before he tripped it. If the tripwire is broken, a series of simple latches is released, allowing four inset stone slabs to fall into storage areas beneath them.

Behind the four slabs await four mummies. Naturally, the mummies attack anyone in the passage once they are released. For many builders, undead creatures are ideal guardians because of the low cost of maintenance involved in their upkeep.

It is important to remember that the listed challenge rating is for this trap only, not for the mummies described above. DMs using this trap may choose to modify the creatures used to adjust to her players' average party level.

A keen-eyed rogue may notice the tripwire that extends across the passage floor. Other

signs of foul play may be the stench of the mummies' rot that hangs in the stale passage-way air. To disarm the trap, a rogue need only avoid the tripwire or secure the tripwire with a successful Disable Device check (DC 20).

## TRICK COIN

---

**Trap Type:** Deadfall Trap  
**Construction Type:** Simple mechanical  
**Activation Type:** Instant  
**Trigger:** Local; tripwire  
**Mechanism:** Gravity  
**Effect:** Injury  
**Attack Bonus:** No attack roll necessary  
**Damage:** 4d6  
**Save:** Reflex save (DC 15) avoids  
**Search DC:** 20  
**Disable Device DC:** 20  
**Challenge Rating:** 2  
**Construction Time/Cost:** 2 weeks; 2,000 gp

A single silver piece carefully positioned on the floor and attached to a thin wire acts as the trigger for this trap. Picking up or moving the coin pulls the wire and opens a sliding gate in the ceiling, which dumps stones on everything within 15 ft. of the coin.

Victims caught by the falling stones take 4d6 points of damage, with a Reflex save (DC 15) avoiding damage altogether.

The victim can keep the coin as long as he survives the trap. This trap can be set in a dungeon hallway, a room, or basically anywhere with a ceiling. If the trapped coin is hidden amongst a pile of other coins, the Search DC increases to 26 due to the challenge of locating such a well-hidden trigger.

## BLACKSTONE'S CHAIN FIST

---

**Trap Type:** Net Trap  
**Construction Type:** Complex mechanical  
**Activation Type:** Instant  
**Trigger:** Local; switch  
**Mechanism:** Gravity, counterweight  
**Effect:** Ensnarement, injury  
**Attack Bonus:** +8 melee  
**Damage:** 2d6  
**Save:** Special  
**Search DC:** 21  
**Disable Device DC:** 21  
**Challenge Rating:** 3  
**Construction Time/Cost:** 3 weeks; 3,000 gp

Blackstone's Chain Fist is typically constructed in a room with few furnishings and roughly equal dimensions; to work properly the trap must have four walls. In the temples, palaces and mausoleums where the trap is most often deployed, such spartan anterooms are not at all uncommon.

The trap consists of a series of vertically aligned chains anchored in the center of the ceiling, fanning outward along the ceiling, down the walls, and running back to a central point beneath the floor—where they are attached to a very heavy counterweight. A large pressure plate in the center of the room releases the weight, activating the trap.

Detecting the trap is difficult, because the chains are hidden from sight, usually beneath a thin layer of plaster matching the surrounding surface or behind breakaway wood veneer. Unsprung traps are very difficult to detect, as are expertly reset traps, but clumsily reset traps may be betrayed. Poorly applied plaster may not quite match the wall's texture or coloration, revealing thin discolored lines running down the walls. Wood veneer may be crudely applied or its varnish could imperfectly match the surrounding wood. In such cases—which usually arise when humanoids are maintaining a trap designed by more skilled or careful folk—the Search DC is reduced to 15.

The pressure plate is the most likely aspect of the trap to be detected. Disarming the trap is a matter of disabling the pressure plate.

The trap is activated when someone steps on the pressure plate, dropping the counterweight. Chains burst from the wall with great speed, gathering people (and objects) within their steely meshes, and mashing them into a painful vise of flesh at the center of the room. With a successful Reflex save (DC 20), people positioned at the outer edges of the trap can escape its clutches by twisting through the chains as they fly past, because the gaps between the chains average seven to 10 inches in width. Those standing just within an opening to the room escape with a successful Reflex save (DC 15). The unfortunate people standing within 10 ft. of the trigger do not receive a saving throw; by the time the chains reach them, there are only four-inch gaps between them.

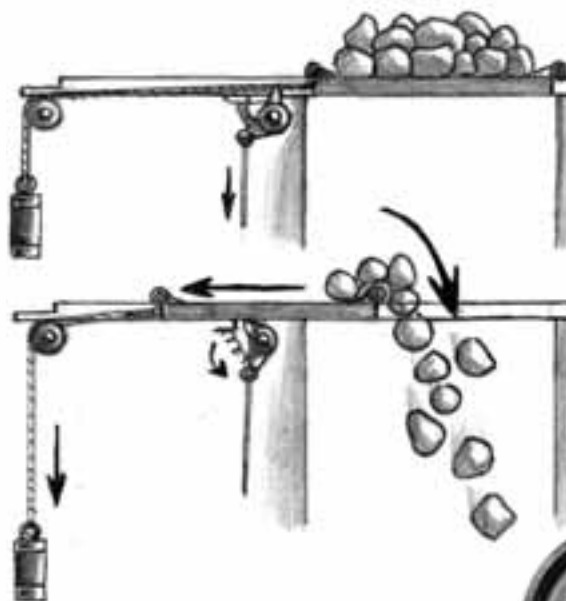



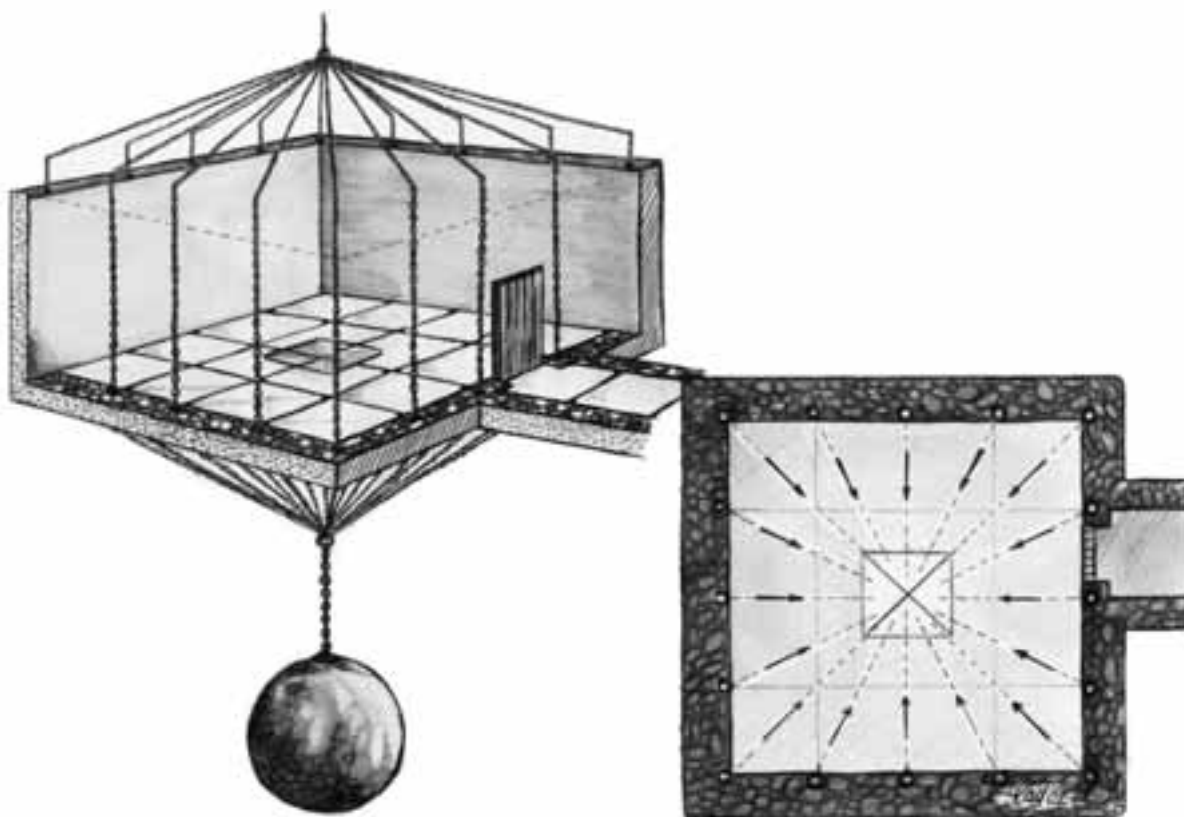

The counterweight exerts considerable pressure on those caught within the trap—the damage inflicted is due to constriction within the stout chains. Additional damage might result from self-inflicted wounds; those who fail to drop sharp weapons or lanterns as the chains sweep them up may find cause to regret it. There is a 50% chance that any piercing or slashing weapon deals its damage to a random trapped character on the round after the trap is sprung.

If allies remain at large, escaping Blackstone's Chain Fist is a matter of snapping a few chain links with a small pry bar or saw (readily available in any thieves' kit), or of detaching the chains from the anchor in the ceiling by loosening the now-exposed bolts. Escaping from within the trap is a bit more difficult. Movement is severely restricted, and getting at tools or weapons might well be impossible. The Chain Fist is a Large net with a Strength bonus of +2, so the trap's Grapple DC is +14.

*Variations:* More deadly versions of this trap may be created by placing items in the room that will inflict damage on anyone who is caught in the chain vice along with them.

Possibilities include heavy iron spheres, large spiked caltrops and terra cotta bottles of deadly acid. Such additions do make the presence of a trap a good deal more obvious.

## BOOKCOVER BLADE TRAP

**Trap Type:** Item Trap  
**Construction Type:** Complex mechanical  
**Activation Type:** Instant  
**Trigger:** Local; switch  
**Mechanism:** Spring  
**Effect:** Injury  
**Attack Bonus:** No attack roll necessary  
**Damage:** 2d6  
**Save:** Reflex save (DC 15) avoids  
**Search DC:** 21  
**Disable Device DC:** 27  
**Challenge Rating:** 3  
**Construction Time/Cost:** 3 weeks; 3,000 gp

A popular item trap, this thick book cover contains numerous sharp blades that are secreted away in thin slots arranged on all sides of the book. A particularly common design uses two vertical and two horizontal bands of iron, jointed carefully and bolted to the wooden cover. The metal lock is arranged in such a way that

the application of acid is likely to burn through and damage the book itself. The cover design, even without a trap, makes the book extremely difficult to open; doing so requires a successful Craft (bookbinding) check (DC 24) or Open Lock check (DC 21).

Once unlocked or picked, a bar is slid into the lock, letting the band around the cover swing free. Moving the bar also uncovers a small bit of light sensitive material. When exposed to light, it releases the mechanism and various blades all over the cover snap out, causing 2d6 points of damage to anyone holding the book. This can be averted by carefully covering the light sensitive area with a hand or cloth before sliding back the bar. Once the bands blocking the cover swing open, the bar can be slid back into place, blocking the sensor. The book can now be used normally.

If the trap is sprung, the blades remain protruding from the book until a mechanism on the inside of the cover is turned. This pulls the blades back in and winds the spring. While the blades are protruding, handling the book (picking it up or moving it) requires another Reflex save (DC 10) to avoid 1d6 points of damage.

Noticing a Bookcover Blade trap is relatively simple, as the slots for the blades are difficult to conceal. Examining the lock itself shows no sign of a trigger, which is a strong indication that the trigger can be found in another part of the mechanism.

There are several ways to disable this trap. Careful application of acid or cutting tools can cut the arm that holds the cover closed, avoiding the lock entirely. This is not a simple or easy process, taking 1d4 hours to complete without damaging the book inside. Trying to access the springs and mechanisms of the blades is significantly more difficult.

If a character succeeds at his Disable Device check by 5 or more, he gets a clue that the light sensors are in some way involved. Such a success means the lock can be opened without actually breaking the mechanism, by either covering the sensor with wax in the dark, or using a cloth. This level of success takes a normal length of time.

Although not as common as other traps due to the complexity of the mechanism, light sensors

are particularly popular with dwarves, as they allow mechanisms to be used safely with little effort. Though easy to disarm, light sensors wear slowly and are harder to tamper with directly than switches or other activation methods. The blade mechanism can also be used with other items, such as thrones, chests, or the shafts of weapons. In these cases, activation is more commonly based on a pressure switch.

## CAT'S CLAW

**Trap Type:** Spike Pit  
**Construction Type:** Simple mechanical  
**Activation Type:** Instant  
**Trigger:** Local; pressure plate  
**Mechanism:** Gravity  
**Effect:** Injury  
**Attack Bonus:** No attack roll needed  
**Damage:** 4d6  
**Save:** Reflex save (DC 23) avoids  
**Search DC:** 21  
**Disable Device DC:** 24  
**Challenge Rating:** 3  
**Construction Time/Cost:** 3 weeks; 3,000 gp

Cat's Claw is a deadly trap designed to injure unwary adventurers. The trigger is a hidden pressure plate on the floor. Should a character step on the plate, two metal trapdoors on the ceiling, colored to match the surrounding stone, are released and the ceiling panels 10 feet ahead and 10 feet behind swing out away from the trigger plate. In the ceiling behind the pressure plate is a row of spikes, previously hidden.

Loaded in the ceiling cavity ahead of the pressure plate is a scooplake mechanism shaped like a cat's paw. After the plate is triggered, gravity takes hold and the scoop swings down and lifts the character that triggered the trap unless he makes a successful Reflex save (DC 23). Should the save fail, the paw lifts the character into the spikes in the indentation in the ceiling, which are curved in the same shape as the scoop for maximum effect. The spikes deal 4d6 points of damage to anyone trapped in the scoop.

Anyone in the corridor 10 ft. behind the character who triggers the trap must also make a Reflex save (DC 17) to avoid being hit by the metal trapdoor that drops open to reveal the spikes. If the character fails this save, he takes 1d6 points of damage as the trapdoor smashes into him.

Disabling the trap requires someone to either jam the pressure plate in the floor or jam the ceiling panels by placing a 10-ft. pole or similar item between the ceiling and floor. Resetting the trap is difficult. The pressure plate must be reset, but only after the scoop has been set back into the ceiling. Clever trapmakers attach the scoop to a winch that can be turned to draw it back into its resting position, but this adds an additional layer of complexity (as well as an additional 1,000 gp) to the trap's construction. Otherwise it takes a Strength check (DC 25) to reload the scoop.

## DOOR JAM

**Trap Type:** Crushing Trap  
**Construction Type:** Complex mechanical  
**Activation Type:** Instant  
**Trigger:** Local; switch  
**Mechanism:** Gears  
**Effect:** Injury  
**Attack Bonus:** No attack roll necessary  
**Damage:** 4d6  
**Save:** Reflex save (DC 22) avoids  
**Search DC:** 23  
**Disable Device DC:** 21  
**Challenge Rating:** 3  
**Construction Time/Cost:** 3 weeks; 3,000 gp

Door Jam is a clever trap designed to crush unwary thieves and trespassers.

The trap involves an ordinary door, which may or may not be locked depending on the whim of the trap's creator. The trap itself is not in the door or lock, but behind the door. A flat metal lever sticks out of the floor to a height of eight inches immediately behind the door. Opening the door more than a few inches causes the lever to move backwards, triggering the trap.

Once the lever is pushed, it pulls a wire that is tightly wound around a series of pulleys underneath the floor. The other end of the wire is connected to a metal bar that holds a stone block, behind which is a tightly wound spring. The metal bar stops the spring from shooting out, but when the bar drops, the stone shoots forward and strikes those within 5 feet of the door, dealing 4d6 points of damage to anyone that fails a Reflex save (DC 22).

Disabling the trap can be a problem; the door must be taken off its hinges so that it does not strike the trigger. Otherwise, any Small

character can squeeze through the door with a successful Escape Artist check (DC 15). Once on the other side, the wire can be disabled with relative ease. If the trap is noticed before it triggers, the door can be pushed open with a pole and the trap triggered harmlessly. Discovering the trap can be accomplished by seeing a faint outline of the stone or noticing the trigger before the door opens too far. Resetting the trap is a difficult and frustrating task, as the bar that holds the stone in place is very difficult to line up since it locks into place under the stone. It usually takes multiple attempts by several workers, one pushing on the stone and another jiggling the lever.

## FELLBANK'S DEADLY INSTRUMENTS

The half-mad gnome bard Fellbank was a master craftsman of musical instruments, but his twisted nature led him to create trapped instruments for clients, primarily bards, who had offended him in some way. Most of his unpleasant creations were destroyed by the victim or his family members after doing their bloody work. Alas, more than a few found their way into estate auctions or into the hands of eccentric collectors of the macabre. In these cases, the dangerous instruments were thereby unleashed on an unsuspecting public.

Bards and musicians who know of Fellbank's legacy are always just a little hesitant when picking up a superb instrument of unknown origin; for the unwary player, his next performance could be his last. A successful Bardic Lore check (DC 30) reveals the origin of any instrument examined, and a Knowledge or Craft (musical instruments) check (DC 25) reveals the same information.

**Note:** Under ordinary circumstances, only rogues may use Search to detect complex traps. However, because of their great familiarity with musical instruments, at the DM's discretion bards may also detect Fellbank's traps with a Search check.

Two of Fellbank's most deadly and notable creations are detailed on the opposite page.

## FELLBANK'S DULCIMER OF DOOM

**Trap Type:** Item Trap  
**Construction Type:** Complex mechanical  
**Activation Type:** Instant  
**Trigger:** Local; switch  
**Mechanism:** Gear  
**Effect:** Injury  
**Attack Bonus:** No attack roll necessary  
**Damage:** See below  
**Save:** See below  
**Search DC:** 25  
**Disable Device DC:** 21  
**Challenge Rating:** 3  
**Construction Time/Cost:** 3 weeks; 4,000 gp

This magnificent trapezoidal wooden zither is gilt with gold and etched with artful scenes of fauns reclining on the banks of sylvan lakes. The two hammers used to play the instrument are silver. Fellbank presented this dulcimer as a wedding present to a court bard who wooed a lady of the court away from him. The bard never triggered the trap and it remains dormant, a work of rare but deadly beauty.

The dulcimer may be played safely for extended periods of time. Indeed, it can be used forever by those who know the secret of avoiding its deadly features. Attached to a number of its strings are tiny toggles keyed to a small mechanism box buried within the instrument's interior. When a trapped string is struck by one of the hammers, the toggle flips a minute switch within the box. When the wire stops vibrating, the switch clicks back to its original position. The toggling of switches does nothing until a specific chord is struck and all the switches are toggled at once. When this occurs, a coiled spring drives a small steel rod into a pressurized glass vial, shattering it and releasing a cloud of ungol dust. The dust cloud fills one cubic foot of space in a round and has the following statistics: magic poison, inhaled DC 15; 1 Cha; 1d6 Cha + 1 Cha (permanent loss). Each time the dulcimer is used in a performance, there is a non-cumulative 5% chance that the deadly chord will be struck, causing the trap to be sprung.

A person using and caring for the instrument will not detect the trap; it is too subtle to be discovered by accident, even when changing the strings. Disarming the trap is a matter of opening the dulcimer and removing the mechanism (opening the instrument will deface it, sadly). Avoiding the trap is as simple as declining to play the chord that activates it.

## FELLBANK'S LOATHSOME LUTE

**Trap Type:** Item Trap  
**Construction Type:** Magic  
**Activation Type:** Instant  
**Trigger:** Local; magic  
**Mechanism:** Magic  
**Effect:** Injury  
**Attack Bonus:** No attack roll necessary  
**Damage:** Curse  
**Save:** Will save (DC 16) negates  
**Search DC:** 29  
**Disable Device DC:** 29  
**Challenge Rating:** 3  
**Construction Time/Cost:** 4 days; 3,500 gp; 140 XP

Unlike most of the trapped instruments Fellbank chose to inflict upon others, the Loathsome Lute was one of his favorite personal instruments. He magically trapped it to punish any apprentice or fellow musicians with the gall to play it without his leave.

Fellbank's Loathsome Lute is, in spite of its name, a masterwork lute of rare beauty and elegance, one of Fellbank's masterpieces. It is rather small, to accommodate Fellbank's slight frame, but produces a surprisingly rich sound.

The magic trigger is activated when someone strums the lute for more than five minutes without a break. The lute discharges a *bestow curse* spell upon the player that inflicts an effective six point decrease in Charisma. Uttering the word "cherub" in Gnome disarms the trap for a six-hour period; uttering the Gnome word for "harpy" rearms it.

Detecting the trap will prove to be a challenge for most rogues. There are no visible physical components to betray the lute's pure magical nature, and the lute's construction is, if anything, even more luxurious than the components of the trap itself.

The trap's magic is contained beneath the lute's frets; prying them up reveals minute runes set in silver, each making up a portion of the curse. Carefully filing or cutting away the runes and replacing the frets with new ones destroys the curse, allowing Fellbank's lute to be played safely. An unsuccessful attempt to disable the trap sets it off.

## FRODERICK'S ILLUSORY FLOOR

**Trap Type:** Illusion-Covered Pitfall  
**Construction Type:** Simple mechanical, magic  
**Activation Type:** Instant  
**Trigger:** Local, trapdoor  
**Mechanism:** Gravity  
**Effect:** Injury, movement  
**Attack Bonus:** No attack roll necessary  
**Damage:** 4d6  
**Save:** Reflex save (DC 20) avoids  
**Search DC:** Special  
**Disable Device DC:** 25  
**Challenge Rating:** 3  
**Construction Time/Cost:** 3 weeks; 3,500 gp; 20 XP

Not all traps with magical elements involve complicated enchantments and the Craft Magic Trap feat. Froderick's variation on the all-too-common illusory floor is one example of this fact. Instead of simply covering a hole with a permanent illusion, a trick too easy to defeat since illusions do not have actual substance with which to thwart tapping or gravity, Froderick covered not only the hole but also 15 feet of collapsible floor on either side of the hole with a permanent illusion.

As a result, poking and prodding ahead does not reveal the illusion, for it covers solid material. Once more than 50 lb. passes more than 5 feet across a collapsible section, the floor gives way, pivoting sharply down. The trespasser plunges through the permanent illusion into a steeply angled funnel that leads to a 40-ft. drop into a lower dungeon level. The collapsible floor sections spring back into place once there is no more weight on them, although they are sometimes set to delay for several rounds in case a trapped character's friends wish to follow him.

A Search check cannot reveal this trap, but interacting with the floor in this manner does permit a Will save (DC 20) to notice that the floor is an illusion. If this saving throw fails, no Search check, no matter how high the result, detects the trap. The simple act of probing ahead with a staff or pole, for example, is not sufficient interaction to allow the Will save to notice the illusion. A falling character can attempt a Reflex save (DC 20) to halt his drop into the vertical shaft. In most cases, he still falls through the "floor," but halts his descent in the funnel.

Disabling the collapsible floor sections is difficult. It requires the rogue actually entering the funnel without falling into the pit and then wedging the sections in place from the underside.

## IMPALING TREE

**Trap Type:** Impaling Defense Trap  
**Construction Type:** Magic  
**Activation Type:** Instant  
**Trigger:** Local; magic  
**Mechanism:** Magic  
**Effect:** Injury  
**Attack Bonus:** +8 melee  
**Damage:** 4d6  
**Save:** Reflex save (DC 17) partial  
**Search DC:** 28  
**Disable Device DC:** 28  
**Challenge Rating:** 3  
**Construction Time/Cost:** 1 week; 2,500 gp; 100 XP

This trap is usually worked into the trunks of trees that hold elven scouts or lookout posts. Such trees are found scattered throughout most forests with a large elven population, and can be identified by the keen-eyed by the small platforms built into the upper layers. Such platforms often hold supplies and ammunition, so they are ideal targets for bandits.

Unfortunately for those who would rob the elves, even an abandoned tree is not unprotected. A fairly simple ritual creates an Impaling Tree. Anyone climbing it without first speaking a safeword finds the tree sprouting long, lethal spikes from the trunk and branches. A Reflex save halves the damage, but the sudden shock can cause even a skilled climber to fall. A Climb check (DC 28) is required to avoid plunging from the tree. The spell usually does not activate until a climber is at least twenty feet up, so the fall often finishes what the spikes began.

Should a climber survive the spikes and retain their grip, there is a slight boon. The now-spiky tree is much easier to climb, reducing the Climb check DC for the remainder of the ascent by 5.

Possible means of detecting this trap include noticing odd lines carved very subtly in the trunk of the tree, flowing along the lines of bark but glistening with eldritch power. There may be odd distortions in the bark where the

spikes had previously erupted, or a character might notice a corpse riddled through with what at first seem to be arrow wounds, but which on closer examination were clearly made by something else.

Disarming the trap can be accomplished by making careful incisions in the bark in order to disrupt the spell.

## INFECTIOUS MELODY

**Trap Type:** Enchantment Trap  
**Construction Type:** Magic  
**Activation Type:** Instant  
**Trigger:** Remote; magic  
**Mechanism:** Magic  
**Effect:** Ensnarement  
**Attack Bonus:** No attack roll necessary  
**Damage:** None  
**Save:** Will save (DC 17) negates  
**Search DC:** 30  
**Disable Device DC:** 30  
**Challenge Rating:** 3  
**Construction Time/Cost:** 3 day; 3,100 gp; 150 XP

The Infectious Melody trap can be placed on a music box or a musical instrument to prevent theft. A command word, which usually only the owner knows, activates and deactivates the trap. When deactivated, the magically trapped object can be handled normally. When activated, merely touching the object triggers the trap, causing the musical object to begin playing a magical tune that compels anyone who hears it to dance.

Only those who hear the first few notes of the magical melody are so affected, and they dance as long as they are physically able to hear the music. A Will save (DC 17) negates the enchantment. The song ends in five rounds if the one who triggered the trap made her saving throw. Affected victims enjoy the music so much that they have no desire to leave the area. An affected individual suffers one point of temporary Constitution damage for each 10 minutes spent dancing. When the victim's Constitution reaches 0, he drops to the floor dead.

The musical instrument plays until deactivated or no victims remain within its area.

## LIGHTNING AND MIRRORS

**Trap Type:** Lightning Magic  
**Construction Type:** Magic  
**Activation Type:** Instant  
**Trigger:** Local; tripwire  
**Mechanism:** Magic  
**Effect:** Injury  
**Attack Bonus:** No attack roll necessary  
**Damage:** 5d6  
**Save:** Reflex save (DC 12) partial  
**Search DC:** 21  
**Disable Device DC:** 28  
**Challenge Rating:** 3  
**Construction Time/Cost:** 2 days; 250 gp; 10 XP

The Lightning and Mirrors trap is a simple tripwire that activates a *lightning bolt* and fools the victim into walking straight into it. The bolt deals 5d6 damage and hits all targets in its path. The trap is set at a point in a hallway where travelers are approaching a T-junction.

Two mirrors, one carefully placed on the wall directly across from the approaching corridor and the other on the left corridor create the illusion of a four-way intersection. Travelers coming from the southern corridor will think that the passage branches to the right, to the left, and continues straight ahead.

A Spot check (DC 25) allows a character to figure out that the northern corridor is merely an illusion. A victim activates this trap by stepping on a tripwire placed at the end of the corridor so that the trap goes off just as the character reaches the T-junction. A wand on the eastern corridor made to look like a torch holder immediately fires a *lightning bolt* towards the junction and the unfortunate victim. However, the mirrors reflect the bolt, giving the victim the impression that the lightning is coming from the north passage.

The victim can try dodging down any of the four passages. If the victim chooses south, the direction he just came from, he will dodge the *lightning bolt* altogether. If the victim chooses north, he slams into the mirror, shattering it and stunning himself, and takes full damage from the *lightning bolt*. If the victim chooses east or west, he may make a Reflex save (DC 14) to take half damage.

## MAGNETIC WALL

**Trap Type:** Arrow Trap  
**Construction Type:** Magic  
**Activation Type:** Instant  
**Trigger:** Local; switch  
**Mechanism:** Spring  
**Effect:** Injury  
**Attack Bonus:** +4 ranged  
**Save:** None  
**Search DC:** 20  
**Disable Device DC:** 28  
**Challenge Rating:** 3  
**Construction Time/Cost:** 3 weeks; 3,000 gp; 250 XP

The Magnetic Wall trap not only harms intruders, it also pins them to a wall. A 10 ft. by 10 ft. stone-tiled room with one entrance and one exit houses the trap mechanism. The doors to the room are made completely of wood with stone hinges. On the rightmost wall, several dozen arrow tips lie in notched holes. A large stone enchanted with a strong magnetic property on one side lies hidden behind the opposite wall. Before activation the enchanted side of the stone

faces away from the room. Stepping on a specific tile in the center of the room triggers the trap. When the pressure plate below the tile is depressed, a series of ropes spins the enchanted stone 180 degrees so that the magnetized side now faces the wall with the arrows. All metal is immediately drawn to the leftmost wall. A victim carrying a metallic object, such as a sword or bag of gold, can make a Reflex save (DC 16) to drop the object before getting dragged along. Victims wearing metallic armor receive no save and are automatically thrown against the wall (armor crafted partially of metal, such as studded leather, allows a Strength check (DC 15) to act normally for the round). The arrow tips, all 24 to 36 of them, fire from their holes. Victims pinned to the wall are considered stunned for the purposes of the arrow attack. The arrows deal 1d4 damage each and the DM can roll 1d10 to determine how many arrows strike a single target.

Freeing magnetized objects from the wall by pulling requires a Strength check (DC 22). Sliding an object along the wall to free it requires a Strength check (DC 16). Individuals in metal armor can free themselves by slipping out of the

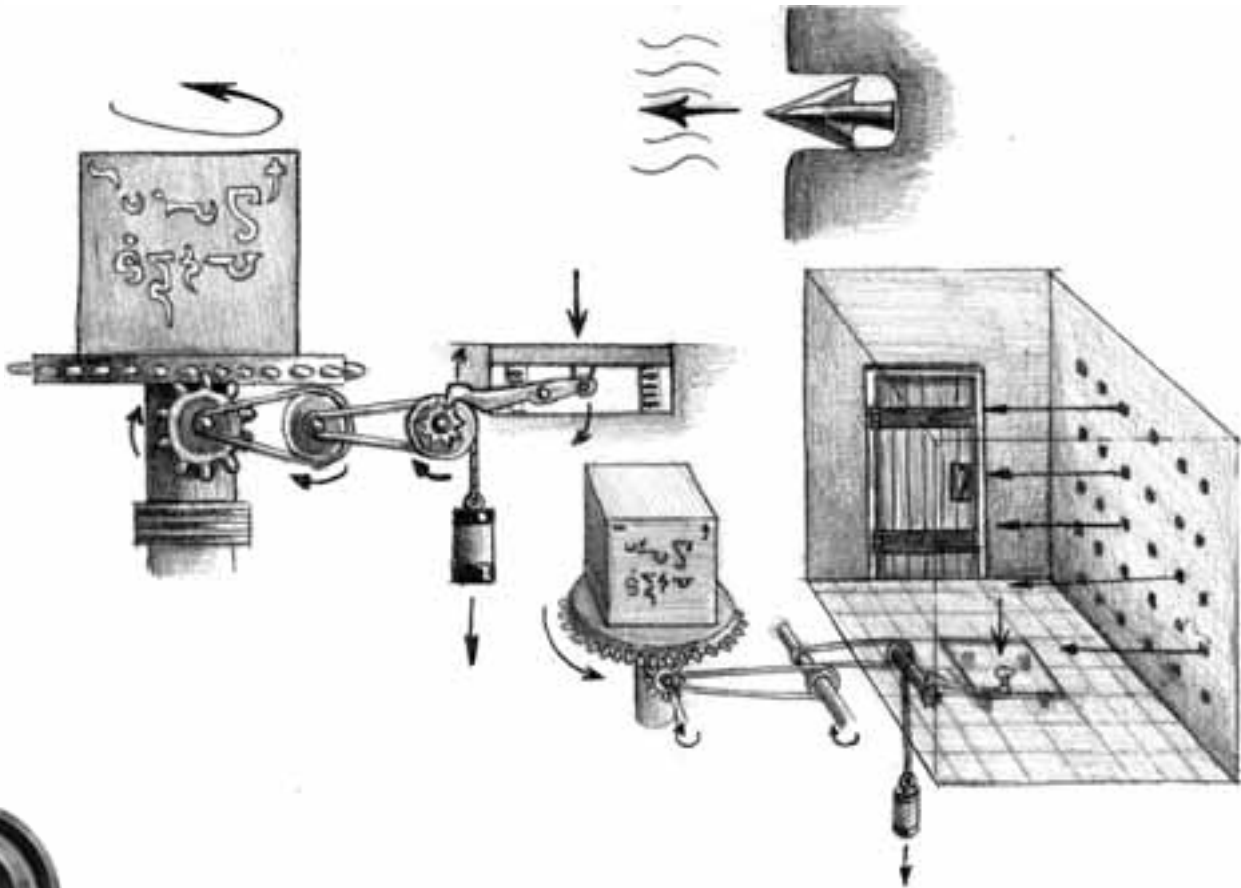

armor with a successful Escape Artist check (DC 18). Victims hit by an arrow and pinned against the wall must remove each arrow with a Strength check (DC 16) before they can be freed.

## MOGRO'S SPRING-LOADED SLAYER

**Trap Type:** Pit Trap  
**Construction Type:** Complex mechanical  
**Activation Type:** Instant  
**Trigger:** Local; trapdoor, gear  
**Mechanism:** Gravity, spring  
**Effect:** Injury  
**Attack Bonus:** No attack roll necessary  
**Damage:** 2d6 falling and 2d6 spikes  
**Save:** Reflex save (DC 22) avoids  
**Search DC:** 21  
**Disable Device DC:** 21  
**Challenge Rating:** 3  
**Construction Time/Cost:** 3 weeks; 3,000 gp

Mogro's Spring-Loaded Slayer is an insidious creation of the mad archpriest Mogro. The dungeon levels beneath his temple have quickly become the stuff of legend and traps such as this are but one reason why. The Slayer uses a combination of a simple pit trap, a spring-loaded platform, and a set of concealed ceiling spikes to foil the efforts of trespassers or aspiring dungeon crawlers.

This trap is found within dungeon complexes, castles, or strongholds of the wealthy or mad. It is generally placed within a simple stonework passageway, so as not to attract suspicion. The trap is activated when a trespasser steps onto the trapdoor placed over a 20-ft.-deep stone pit. A character who makes a successful Reflex save (DC 22) avoids falling into the pit. Those who fail their save fall into the pit and suffer 2d6 points of damage. Additionally, when the trapdoor is opened, a series of gears activates a release mechanism that is situated over the pit. The gears open a storage compartment that releases a set of metal spikes that drop and lock into place 5 feet above the open pit.

The final step of this trap is activated when a character lands at the bottom of the pit trap. The pit's floor is actually a spring-loaded platform that is released when a character lands on it. The platform springs upward, launching the victim towards the ceiling spikes. A character that is launched into the spikes suffers an additional 2d6 points of damage.

Surviving characters have another problem: the passageway is now blocked. The only methods of continuing involve climbing either down the pit and back up or over the platform. Doing either has dire consequences. The trap is crafted to respond to any weight, either below or above, that is placed on it before it resets. If any character attempts to bypass it before this happens (20 minutes after it is initially set off), the platform lurches to crush them. If the character is climbing over the platform (Climb check DC 10), it presses up once again, forcing the character into the spikes for 2d6 points of damage unless a Reflex save (DC 22) is made. Characters climbing down into the pit are fine until they reach the bottom, at which time the platform falls down on them for 5d6 points of damage with no save. In addition, the character is now pinned beneath the platform and trapped within the pit.

A sharp-eyed rogue may notice the contours of the hidden trapdoors on the floor and ceiling of the passageway. To disarm the trap, a rogue need only jam the trapdoor in the floor or cover it with a large object.

While Mogro originally conceived the Slayer, the design has slowly slipped out across the free lands (distributed typically by rogues who have survived forays into the famous lower temple levels). As such, the design has seen many creative and sadistic variations, with poisons and spell additions being the most popular.

## NO FLY ZONE

**Trap Type:** Dispel Magic  
**Construction Type:** Magic  
**Activation Type:** Instant  
**Trigger:** Local, magic  
**Mechanism:** Magic  
**Effect:** Injury  
**Attack Bonus:** No attack roll necessary  
**Damage:** See below  
**Save:** Will save (DC 18) negates  
**Search DC:** 28  
**Disable Device DC:** 28  
**Challenge Rating:** 3  
**Construction Time/Cost:** 3 days; 2,500 gp; 100 XP

Rumor has it that this trap was first commissioned, believe it or not, by a rogue; if this is true, however, the rogue's name is now lost to history. The legend has it that the



rogue fell in with a party of adventurers and had a profitable, if risky, career for a time. After a year or two of skulking around forgotten tombs and abandoned castles, he found a lot of his utility wasting away. The party wizard casually tossed around *knock* spells to open chests and, especially annoying to the nimble rogue, used *fly* spells to make the need for climbing skills superfluous. Thus it was that this trap was conceived, and a cunning plan hatched to lure the entire party into the dungeon where it had been placed. The final fate of the party is unknown; sages suspect that the trap worked well, and then, without a wizard, the party was destroyed by a demon or similar creature that is immune to non-magic attacks. No one knows for sure, but the mechanism of the trap has spread to many lands.

This trap is usually baited thus: a valuable treasure or important passageway is placed high off the ground (at least 60 feet) but in such a position as to be visible from below. The walls leading up to the area are especially smooth and slick, making passage by climbing very difficult.

About 50 feet up, or 10 feet below the goal, a *dispel magic* (5th caster level) is triggered. The wizard has just enough time to yelp before she plummets toward the ground. Particularly nasty variants of this trap have additional *dispel magic* spells set to trigger incrementally down the wall, so that even a *feather fall* spell will be negated.

Detecting this trap requires sensing the odd aura surrounding the walls, having some foreknowledge of this sort of trick, or seeing an oddly mangled skeleton in the center of the room.

## PIT GALLERY

---

**Trap Type:** Pit Trap  
**Construction Type:** Complex mechanical  
**Activation Type:** Instant  
**Trigger:** Local; tripwire  
**Mechanism:** Counterweight  
**Effect:** Injury  
**Attack Bonus:** See below  
**Damage:** See below  
**Save:** Reflex save (DC 23) avoids  
**Search DC:** 21  
**Disable Device DC:** 21  
**Challenge Rating:** 3  
**Construction Time/Cost:** 3 weeks; 3,000 gp

Pit Gallery is a complex mechanical trap designed primarily to injure, but also to capture, intruders. The room is designed to appear as a small art gallery with six paintings signed by Claus De Vonn, an obscure artist possibly known to the viewer (Bardic Knowledge check DC 23 or Knowledge (art) check DC 28). A stone table stands on a mosaic pattern in the center of the room. The paintings are all poorly rendered portraits of well-known nobles. They would not fetch a worthy sum on the open market, but the sculpted frames are made of pure silver and could be sold fairly easily (45 gp each).

Pulling any of the frames causes the trap to spring. The floor collapses, its pivot point at the center of the room, sending all viewers tumbling into a pit trap. Anyone standing next to the table or doorway receives a +2 bonus to his Reflex save. Those who fail the save tumble into the 20-ft.-deep spiked pit trap, taking 2d6 points of damage from the fall as well as possibly impaling themselves on several spikes. 1d4 spikes strike each character for 1d4+2 points of damage per spike. The spikes have a +10 melee attack bonus.

After it is sprung, a series of gears, pulleys, and counterweights are set to immediately close the apparatus. The process is fairly quick, requiring only six rounds to reset. Only pulling another picture frame or destroying the gears from below can stop the reset mechanism.

The only way to disable the trap from above is to cut the wires behind each picture frame. Each picture requires a separate Disable Device check in order to completely neutralize the trap. It would be easy to sabotage the trap by destroying the mechanisms that release and reset the floor, but this can only be accomplished after the trap is sprung.

## SOWER OF CHAOS

---

**Trap Type:** Charm Trap  
**Construction Type:** Magic  
**Activation Type:** Instant  
**Trigger:** Local; magic  
**Mechanism:** Magic  
**Effect:** Hindrance  
**Attack Bonus:** No attack roll necessary  
**Damage:** None  
**Save:** Will save (DC 13) resists  
**Search DC:** 28

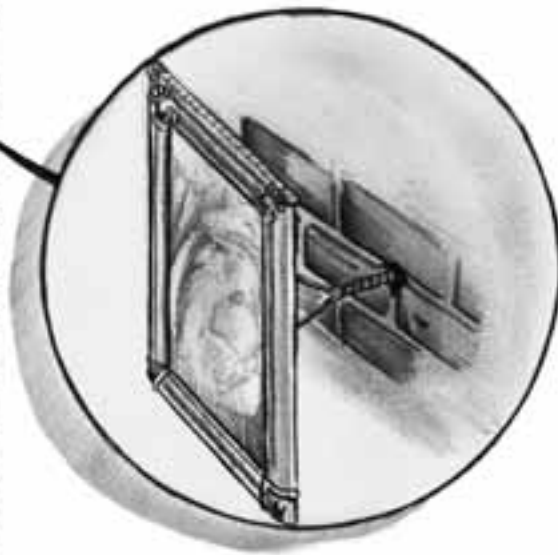

**Disable Device DC:** 28  
**Challenge Rating:** 3  
**Construction Time/Cost:** 4 days; 2,000 gp; 80 XP

This can be quite a deadly trap, depending on the party, using magic to turn them against each other. The sigil can be on a door, a chest, or along the floor; it also works quite well as an item trap.

The trap itself combines *message* and *suggestion* to silently tell the triggering character one of two messages, depending on how it was set up.

The first message is straightforward: “*These people you are with, they are working against you. You must destroy them soon.*”

The second is subtler and works well for games in which characters have a lot of depth. The message is “*You can really trust your friends. You should tell them your deepest, darkest secrets, now.*”

There are obviously many other messages that can be crafted to suit each particular party. Items with such magic on them may provoke paranoia or protectiveness of the item, at least

until the spell trap runs out. Such magic may also work as a kind of *geas*.

## SPIDER ON THE BRIDGE

**Trap Type:** Bridge Trap  
**Construction Type:** Magic  
**Activation Type:** Instant  
**Trigger:** Local; magic  
**Mechanism:** Magic  
**Effect:** Ensnarement  
**Attack Bonus:** No attack roll necessary  
**Damage:** See below  
**Save:** Reflex save (DC 13) avoids  
**Search DC:** 24  
**Disable Device DC:** 24  
**Challenge Rating:** 3  
**Construction Time/Cost:** 1 day; 1,500 gp; 60 XP

Spider on the Bridge is a magic trap designed to both entangle and possibly kill intruders. It is best placed on a narrow bridge that runs next to a wall, ideally over a body of water that is home to aquatic dangers such as snakes or sharks. Halfway across the bridge is the trigger for a *web* spell: an arrangement of smooth black rocks arrayed upon the ground to resemble the eyes of a spider. Any creature walking past the stones without



mouth the password triggers the trap.

Should the trap be set off, a *web* spell fires from the wall, causing all within 20 feet of the trigger to make a Reflex save (DC 13) to avoid being entangled in the spell.

Those who make their initial save are subject to the second portion of the trap. Due to the narrow footing, those dodging the *web* must succeed at another Reflex save (DC 20) or plunge off the bridge. They take no damage from the fall (2d6 if there is no water) and must swim to safety while dealing with the creatures in the lake.

As the trap has no mechanical portion, detection is difficult. A rogue must make a successful Search check (DC 24) to detect the active magic. He may sense an odd energy in the area of the trigger or notice a sticky residue on the ground just before the stones. Disabling the trap is equally difficult; it would be easier to simply avoid the trap by leaping over the trigger. Climbing to the point at which the spell is cast requires a successful Climb check (DC 15), and disabling the trap requires a successful Disable Device check (DC 24) while clinging to the wall.

## STEP IN BLAST

**Trap Type:** Fire Trap

**Construction Type:** Magic, simple mechanical

**Activation Type:** Instant

**Trigger:** Local; magic

**Mechanism:** Magic

**Effect:** Injury

**Attack Bonus:** No attack roll necessary

**Damage:** 5d6

**Save:** Reflex save (DC 13) partial

**Search DC:** 28

**Disable Device DC:** 28

**Challenge Rating:** 3

**Construction Time/Cost:** 2 days; 1,500 gp; 60 XP

This lovely little trap combines misdirection, magic, and side effects to throw a party into chaos. The layout is a corridor 40 ft. long, 20 ft. wide, and 6 ft. high. The floor is set a few inches lower than the preceding and following area, and is covered with several inches of tar, the surface almost level with the floor outside the corridor. A series of flat stepping stones are set across the way, inscribed with a variety of sinuous patterns. Each is a 2-ft.-diameter disk extending up an inch out of the tar. One is set about 3 feet from the previous, making 15 in all. The design is meant to suggest the tar is deep or might conceal dangers, encouraging the characters to stay on the stones.

Jumping from stone to stone requires a successful Jump check. Characters taking a running jump must also make a Balance check

(DC 12) for each stone or fall into the tar.

The eighth stone has the spell trap on it, and triggers any time more than 50 lb. is placed upon it. Activating the trap releases a *fireball*, dealing 5d6 points of damage to anyone within 20 feet. The fire ignites the tar within 20 feet of the trigger point, creating an area of flame.

Characters within this 20-ft. radius must move out of the corridor or take an additional 1d6 points of damage per round in which they remain inside the flames. Movement out of the area can be along the stepping stones or directly through the tar. If the character moves through an area of burning tar, his feet become covered in the stuff. He takes 1d4 points of damage per round until he can scrape the burning tar off his feet, a standard action.

On the second round, the fire begins to spread, filling the entire 40-foot length of corridor. This is otherwise like the first round for anyone in the area of fire. In addition, on this round anyone within the corridor or up to 10 feet beyond is subject to smoke inhalation (DMG 89). Each subsequent round the area of smoke expands 20 feet in each direction.

The smoke and the flames last another 3 rounds (5 in all). At the end of the fifth round, the fire burns out, and the smoke extends 70 feet beyond the corridor in both directions. In two rounds the smoke clears enough so that there are no further smoke inhalation checks.

The design certainly encourages characters to inspect the area carefully. One common assumption may be that one of the stones is loose, causing someone to slide into the dangers of the tar. Poking at the tar near one end shows it to be shallow, but intruders are unlikely to conclude that it is safer to cross through the tar. The patterns of the middle stone are subtly different and more intricate than the rest, a hint of something unusual. Careful chiseling breaks the pattern, destroying the trap and allowing safe passage over the stones.

## THE GRINNING SKULL

**Trap Type:** Gas Trap  
**Construction Type:** Simple mechanical  
**Activation Type:** Extended  
**Trigger:** Remote; lever  
**Mechanism:** Pressure

**Effect:** Ensnarement  
**Attack Bonus:** No attack roll necessary  
**Damage:** Poison  
**Save:** Fortitude save (DC 18) negates  
**Search DC:** 20  
**Disable Device DC:** 25  
**Challenge Rating:** 3  
**Construction Time/Cost:** 3 weeks; 3,350 gp

The Grinning Skull trap is designed to incapacitate victims for later disposal by guards or wandering monsters. A silver-inlaid etching in the shape of a skull with a tiny hole in the left eye socket hides the trap. This etching could be on a wall, alcove, door, pedestal or floor, and serves as the center point for a cloud of sleeping gas. Contained in a pressurized tube, the gas erupts from the trap when a specific lever is depressed.

The gas cloud has an initial 10-ft. radius burst and quickly spreads an additional two feet per round for five rounds. The gas remains in the vicinity for one minute before dispersing. Victims that are caught in the cloud and fail a Fortitude save (DC 18), fall into a deep slumber for 1d4x10 minutes. Waking a sleeping character counts as a standard action and requires loud shouting or slapping.

Pouring water down the left eye socket clogs the tube and renders the gas harmless.

## THE POISONED STONE

**Trap Type:** Needle and Deadfall Trap  
**Construction Type:** Simple mechanical  
**Activation Type:** Instant  
**Trigger:** Local; switch  
**Mechanism:** Pressure, gravity  
**Effect:** Injury  
**Attack Bonus:** +10 ranged  
**Damage:** 1d4 (needles) plus poison and 4d6 deadfall  
**Save:** Reflex save (DC 22) avoids  
**Search DC:** 20  
**Disable Device DC:** 20  
**Challenge Rating:** 3  
**Construction Time/Cost:** 3 weeks; 3,000 gp

The Poisoned Stone trap utilizes two simple elements, a poisoned needle trap and a large deadfall, to severely punish the curious.

Placed within narrow corridors in dungeon complexes and underground cav-

erns, the first stage of this trap is activated when a character steps on a concealed pressure plate within the trapped passage. The pressure plate triggers two different effects, which activate simultaneously. First, a pressure-loaded poisoned needle gun is fired into the area of the pressure plate. The needle is coated with poisons that slow or paralyze the victim (DMG 80). A wounded character suffers 1d4 points of damage as well as the poison's effects.

As the needle is fired, a second mechanism releases a large stone deadfall from above the pressure plate area. A character in this narrow area must make a successful Reflex save (DC 22) or suffer 4d6 points of damage. The character is also considered pinned. A successful Strength check (DC 20) is required to escape from the weight of the stone block.

A rogue may notice either the slightly discolored pressure plate in the floor or possibly smell the odor of the poison within the gun. A rogue need only jam the pressure plate with a dagger or climbing piton to diffuse this trap.

## TIME'S UP

---

**Trap Type:** Item Trap  
**Construction Type:** Simple mechanical  
**Activation Type:** Instant  
**Trigger:** Local; chemicals  
**Mechanism:** Gravity  
**Effect:** Injury  
**Attack Bonus:** No attack roll necessary  
**Damage:** 5d6 plus poison  
**Save:** Fortitude save (DC 20) resists  
**Search DC:** 20  
**Disable Device DC:** 22  
**Challenge Rating:** 3  
**Construction Time/Cost:** 2 weeks; 5,000 gp (includes cost of chemicals and hourglass)

This trap is a simple design that takes advantage of a violent alchemical mixture to slay those who cannot leave well enough alone. An ornate brass hourglass lies on its side on top of a chest, table, or on the floor of a room full of other items. A casual glance at the hourglass reveals that the sand is all on one side of the twin glass globes, filling it half way. In reality, the sand is a dry chemical mixture, and the empty globe is half full of a clear liquid that reacts violently with the contents of the other globe. As long as the hourglass is left on its side, nothing happens. Once it is tilted so

that the sand and liquid begin to mix, the trap is sprung in one of two equally deadly ways.

Examining the hourglass carefully reveals two clues that indicate that all is not as it seems. The liquid is the first clue, while the second is that there are tiny holes drilled in the glass near the middle of the item, allowing air to enter as the chemicals mix and poisonous gases to vent from the item.

If the hourglass is tipped so that the dry chemicals sift into the clear liquid, the resulting reaction is vigorous, but not explosive. In this case, a clear, odorless poison gas vents from the hourglass filling a 10 ft. by 10 ft. area in two rounds. The poison typically causes weakness and nausea in its victims unless the character makes a successful Fortitude save (DC 18).

If the hourglass is tipped so that the liquid flows into the powdered mixture, the reaction is much faster and much more spectacular. After one round the hourglass explodes violently, spraying the room with glass and metal shards and dealing 5d6 points of damage to those within 20 feet of the explosion's point of origin. This is also the result of smashing the hourglass, whether deliberately or by accident.

If the hourglass is carelessly picked up and thrown into a backpack or other container, the DM should assign a 50% chance that either event results and proceed accordingly.

## VARLET VISE

---

**Trap Type:** Net Trap  
**Construction Type:** Complex mechanical  
**Activation Type:** Instant  
**Trigger:** Local; switch  
**Mechanism:** Gravity, counterweight, gear  
**Effect:** Ensnarement  
**Attack Bonus:** No attack roll necessary  
**Damage:** None  
**Save:** Reflex save (DC 22) avoids  
**Search DC:** 22  
**Disable Device DC:** 25  
**Challenge Rating:** 3  
**Construction Time/Cost:** 3 weeks; 3,000 gp

Blackstone's Chain Fist pioneered the idea of concealing chain net traps within walls, but his design had a major flaw—it could only be placed in symmetrical rooms. Other trap designers adapted his concept to corridors, giv-

ing rise to the Varlet Vise.

The Varlet Vise consists of two chain nets, cross-woven with five-inch openings, concealed in facing walls and attached to counterweights via a pulley system. The most common manner of concealing the nets is running them into grooves in the walls and covering them with plaster. Some variations nestle the chain beneath the mortar of decorative tiles with wide, deeply recessed grooves. As with Blackstone's Chain Fist, the pressure plate is the most exposed aspect of the Varlet Vise, and the easiest place to disarm it. Detecting a reset trap where mortar has not been reapplied requires a simple Search check (DC 15). The blackened chains may be glimpsed within their niches if a light is shone directly into the recesses.

When the pressure plate is set off, the counterweights pull the chain nets out of the walls at great speed. The nets meet in the middle of the room, trapping whatever they caught up along the way in a new vertical chain link fence standing lengthwise along the corridor.

The trap inflicts no damage, but those caught in it are considered pinned. Victims making a successful Escape Artist check (DC 20) can worm their way free. Releasing people from the trap requires an outside ally to cut the chains running along the ceiling and floors. Once free of the weights, the chain walls can be pulled apart. It is also possible to cut a hole in the net, but this takes a good deal longer.

*Variations:* Builders occasionally place the Varlet Vise near arrow slits or within bowshot of an emplacement or guardpost. Riddling an enemy with arrows while she is caught fast usually makes short work of her.

## VENGEANCE UNLEASHED

**Trap Type:** Item Trap  
**Construction Type:** Magic  
**Activation Type:** Instant  
**Trigger:** Local; magic  
**Mechanism:** Magic  
**Effect:** Hindrance  
**Attack Bonus:** No attack roll necessary  
**Damage:** None  
**Save:** Will save (DC 13) negates  
**Search DC:** 28  
**Disable Device DC:** 28

**Challenge Rating:** 3

**Construction Time/Cost:** 2 days; 1,500 gp; 60 XP

Many relics and important items have curse traps on them. The specific curse depends on the item and the intent of the curse layer. The sacred book of the god of Trickery might opt for an amusing comeuppance, while a dagger consecrated to the Mistress of Plagues will have a darker effect.

The activation of a trap can also be specific. A book's trap could be triggered when opened, or when it is read. A dagger's trap may spring when drawn, used, or when it first spills blood. The spell trap can also be set to activate with a mere touch. Once in operation, the curse remains on the character regardless of what is done with the item.

A trap typically has 50 charges, ready to curse anyone that tampers with the relic. Note that once a curse is set on someone, the trap will not affect that person again unless the curse is lifted.

Possible curses include:

- The character has a -4 penalty to all Charisma-based checks when dealing with people of authority.
- When entering a town for the first time the character must roll a Charisma check. If the check result is less than 15, townspeople will be convinced that the character is a hated villain. A character already openly hated can still be inconvenienced when entering the town in disguise.
- -6 to all attempts to Hide, Move Silently, or otherwise evade attention.
- -6 to all attempts to Bluff, Diplomacy, Disguise, Forgery, Intimidate, or otherwise manipulate others.
- The character cannot heal naturally, even with application of the Heal skill.
- When first entering combat, the character has a 50% chance of dropping held weapons and shields. During combat, any time he draws or picks up a weapon or shield, he has a 50% chance of dropping it. This happens after the character attempts to use it, so he loses whatever action he was about to

take and must use an additional action if he wants to pick it up again.

- Whenever the character goes to sleep, there is a 25% chance that any sleep in the next 24 hours will be plagued by nightmares. Either normal or restless sleep applies to naps or periods of rest the character attempts for this entire period. A nightmare result means the character has not rested and cannot regain arcane spells.
- Animals react poorly to the character, including mounts. Any Animal Empathy, Handle Animal, Ride, and similar skill checks are made with a -6 penalty. This has little effect on familiars or a paladin's mount, other than making them a little touchy with the character.
- The character is at -8 when making Fortitude saves against disease.
- The character becomes paranoid. He is constantly spotting NPCs and PCs out of the corner of his eye rifling through his things, looking at him cruelly, or otherwise acting suspicious. Characters that are already paranoid are inspired to extremes.
- The character becomes blind to threats. As a result he suffers a -6 penalty to all Listen, Search, Spot, and initiative rolls.
- The markings of the trap are hard to make out. A rogue is most likely to notice the trap when appraising the item, or otherwise examining it closely. Obscured by whatever artwork is on the item are characteristic runes and markings outlining the trap. Dripping sealing wax in just the right spot disperses the curse magic.

## VERMIN PIT

**Trap Type:** Vermin-Filled Pit Trap  
**Construction Type:** Magic  
**Activation Type:** Instant  
**Trigger:** Local; magic, switch  
**Mechanism:** Gravity, magic  
**Effect:** Injury  
**Attack Bonus:** No attack roll necessary  
**Damage:** 4d6 fall plus spell  
**Save:** Reflex save (DC 20) avoids  
**Search DC:** 20 (27 for magic)  
**Disable Device DC:** 27  
**Challenge Rating:** 3  
**Construction Time/Cost:** 3 weeks; 3,500 gp; 100 XP

The very simplicity of pit traps makes them less useful—everyone knows about them, expects them, and takes steps to avoid them or minimize the damage from them. Thus, the evolutionary cycle of traps continues, with each new design trying to prove itself superior by finding variations on a theme. This is one such variation.

A simple panel, which opens up when pressure is placed on a switch, usually covers the pit itself. The pit is fairly deep (40 ft.) and thus requires some effort to escape. The walls of the pit are smooth, making climbing difficult (Climb check DC 23) unless someone lowers a rope down. Unfortunately for the person or persons stuck in the pit, there is more to this trap than a simple pitfall.

One round after the trap is activated, a *summon swarm* spell is cast. The swarm so summoned will be fixed at the time of casting, but is usually something quite nasty. Each round, another swarm appears, filling another 5 ft. cube of the pit, until the entire pit (usually 5 ft. wide by 40 ft. high) is completely filled with writhing vermin. Anyone in the pit must climb *through* the swarms, suffering all effects as described in the spell. The spells reset when the trap is reset.

Anyone trying to help the person trapped in the pit must consider the effects of the swarm. Forcing a rope down to the victim exposes them to the ravaging insects. A *fireball* can clear away most of the swarms, but if it is cast before the entire cycle of summoning is complete, the caster will most likely need to cast again. Vermin-affecting spells are the most useful. Anyone in the party who can cast *summon swarm* can attempt to counterspell the spells cast by the pit.

Detecting the magical nature of the pit involves recognizing the arcane symbols that line the upper surface of the pit, or noticing the odd, eldritch sparkle that comes from the crystals placed at strategic locations along the inside of the pit.

## VESHER'S KILLING CUBE

**Trap Type:** Monster Trap  
**Construction Type:** Complex mechanical  
**Activation Type:** Extended  
**Trigger:** Local; switch  
**Mechanism:** Gravity  
**Effect:** Ensnarement, injury

**Attack Bonus:** No attack roll necessary  
**Damage:** 2d6 plus 1d6 acid  
**Save:** Reflex save (DC 16) avoids  
**Search DC:** 21  
**Disable Device DC:** 25  
**Challenge Rating:** 3  
**Construction Time/Cost:** 3 weeks; 3,000 gp

Vesher's Killing Cube is a creation birthed in the mind of the lich trapsmith, Vesher. Known for his talents in trapsmithing as well as his ruthless reputation (cultivated by such creations as the Terrible Tumbler and the Vicious Grinder), each new trap that Vesher creates is unleashed upon a terrified world. By using a series of simple switches, a falling stone barricade, and a gelatinous cube (MM 145), Vesher's Killing Cube has quickly become the bane of many inexperienced dungeon crawlers across all of the free lands.

This trap may be found in dungeon complexes, castles, wizard's towers, or the strongholds of paranoid nobles. It is generally placed within a 10-ft.-wide stone passageway, although alternative mediums may be used. It is recommended that the materials used to create this trap match those used to build the area in which it is placed (such as iron, wood, or marble). Doing so will decrease any cause for added suspicion.

The trap is activated when an unsuspecting character steps upon a simple floor switch (a stone or wood panel, for example). Stepping onto the switch releases a series of three trapdoors. The first two trapdoors release the stone barriers that are held within the ceiling of the passageway. These barriers are 10 feet wide, generally 2 feet thick, and cover the entire width of the passageway. Any character directly underneath a falling barrier must make a successful Reflex save (DC 16) in order to avoid being hit by it. A character that makes his Reflex save may choose to move onto either side of the barrier. Characters underneath a falling barrier who do not make a successful Reflex save suffer 2d6 points of damage and are considered to be pinned (DMG 85) by the barrier. A successful Strength check (DC 20) is required to lift the stone barrier and free a pinned character.

Characters who are trapped between the walls experience this trap's final step as the falling barriers trigger the release of a 10 ft. by 10 ft. trapdoor that is placed over the area. A gelati-



nous cube (MM 145) falls out of the trapdoor, automatically engulfing all those trapped within. Engulfed characters must make a successful Fortitude save (DC 16) or be paralyzed for 3d6 rounds by the gelatinous cube's acidic slime. Additionally, engulfed characters suffer 1d6 points of acid damage each round while trapped within the creature's body.

A rogue who is searching for traps may notice several clues that lead him to discover this danger. One sign may be the slight difference in height of the loose panel in the passageway floor. Also, a rogue may notice one (or all) of the trapdoors hidden within the passage ceiling. Due to a lack of maintenance, a tiny amount of the gelatinous cube's paralyzing slime may secrete through the trapdoor and onto the passageway floor.

There are several ways to disarm or avoid Vesher's Killing Cube. The rogue's first option is to simply avoid the pressure plate in the passage floor that activates the trap. Other options for disarming this trap are jamming the pressure plate with a climbing spike (or similar item) or jamming the trapdoors in the ceiling of the passage.



## NOTE ON MONSTER TRAP CRs

Many of the traps presented in this book feature monsters as part or all of the actual danger involved in a trap. In such cases, the CR listed in the stat block does not take into account the CR of the monster involved. Experience should be awarded separately for the trap as well as the monsters.

## BLACK GARDEN

---

**Trap Type:** Grappling Trap  
**Construction Type:** Magic  
**Activation Type:** Instant  
**Trigger:** Local; magic  
**Mechanism:** Magic  
**Effect:** Ensnarement, injury  
**Attack Bonus:** No attack roll necessary  
**Damage:** 1d6 per attack  
**Save:** None  
**Search DC:** 29  
**Disable Device DC:** 29  
**Challenge Rating:** 4  
**Construction Time/Cost:** 2 days; 2,000 gp; 80 XP

A Black Garden turns the target area into a major obstacle for a significant length of time. The trap can be used at entrances in lands where large animals are rare. Otherwise it is set up within a complex, placed to prevent access to important rooms. The tentacles created are potentially deadly, throttling characters that cannot evade them.

The Black Garden is popular with particularly unpleasant gnomes, especially those who live underground. Neither the trigger nor the spell reacts to creatures smaller than Medium-size. This allows gnomes and other small races to dart in and attack freely even while the trap is active. The spell trap casts *Evard's black tentacles* in the surrounding area. 1d4+7 tentacles are created within a 15-ft. radius. Each tentacle is 10 ft. long, has saves of Fort +2, Ref +2, and Will +5, AC 16, 7 hit points, +7 attack bonus, Strength 19, and is immune to spells that do not cause damage (except for *disintegrate*). The spell effect lasts seven hours.

There is a slight smell of fish accompanying the trceries that make up the spell trap, which could be a clue to an observant rogue. A small drop of acid or some other solvent poured onto three faint symbols disrupts the trap and destroys its magical trigger.

## BRAGO'S ANGER

---

**Trap Type:** Monster Trap  
**Construction Type:** Simple mechanical, magic  
**Activation Type:** Extended  
**Trigger:** Local; switch, magic  
**Mechanism:** Magic, counterweight  
**Effect:** Identification, injury  
**Attack Bonus:** No attack roll necessary  
**Damage:** None  
**Save:** Fortitude save (DC 18) negates  
**Search DC:** 29  
**Disable Device DC:** 29  
**Challenge Rating:** 4  
**Construction Time/Cost:** 1 day; 2,350 gp; 14 XP.

Brago's Anger takes a simple *polymorph other* spell and combines it with the trained fury of a hill giant to place a greedy character in a potentially fatal situation.

This trap is placed in a large stronghold, dungeon, or underground passage, as it should be able to accommodate the size of Brago (who stands 12 feet tall). It should be placed in a larger room, typically an audience chamber or trophy room of some sort. The trap itself is triggered by a large gem of any type placed into the chest of an ornate statue of a wizard or other adversary of the DM's choosing. A successful Appraise check (DC 15) values the gem at no less than 2,000 gp. This will typically be enough to lure a greedy character into the trap.

When touched, the gem casts a specific *polymorph other* spell onto the character. A Fortitude save (DC 18) allows a character to overcome the spell's effects. If a character fails the saving throw, she is *polymorphed* into a form identical to that of the statue, depending on the adversary the DM has chosen. The only restriction is that the adversary must be a Medium-size humanoid, must meet the specifications of the *polymorph other* spell, and must have performed the acts that have trained Brago to react as he does today.

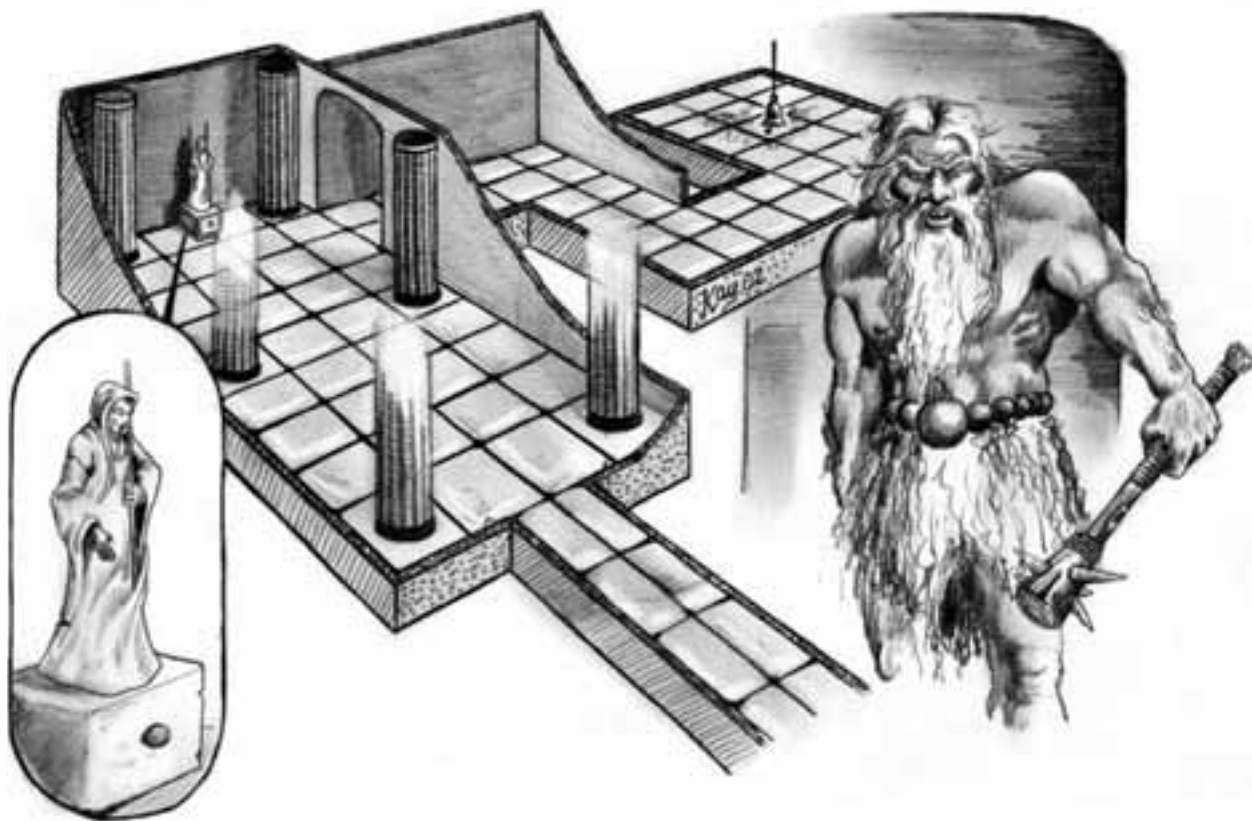

Once the gem has been touched (regardless of the spell's outcome), it sinks slightly into the statue, activating a series of counterweights that rings a bell in Brago's chamber located nearby. Once Brago hears the bell, he flies into a rage and charges into the trapped chamber to attack anyone in the room. If a character has been *polymorphed* by the gem, Brago attacks that character directly and without hesitation, only stopping when the character is dead or escapes, no matter what actions other characters may take against him.

The reason for this is that the adversary depicted by the statue killed Brago's wife several years ago, only weeks after he began the construction of this lair. For several years, the adversary would tease Brago with beatings, spells, and the use of a simple bell. Now after years of abuse, Brago identifies the sound of the bell with the adversary and attacks him on sight. The fact that Brago has killed the adversary (or someone who looked like him) hundreds of times over the years means nothing as he has gone quite insane. Instead he takes the reverted corpses of his victims and eats them, waiting for the real adversary's return.

A simple *detect magic* spell enables a character

to identify the magic on the gem. A keen rogue may notice the groove that allows the gem to sink into the statue, which activates the bell in Brago's chamber. She may also detect the faint trails of dried blood that lead from the hall into the passage that leads to Brago's chamber. To disarm it, she need only jam the mechanism with a dagger or similar object.

## BREATHTAKING CORRIDOR

**Trap Type:** Poison Gas  
**Construction Type:** Simple mechanical  
**Activation Type:** Extended  
**Trigger:** None  
**Mechanism:** Poison gas  
**Effect:** Injury  
**Attack Bonus:** No attack roll necessary  
**Damage:** Pooling breather poison  
**Save:** Fortitude save (DC 12) negates  
**Search DC:** 30  
**Disable Device DC:** None  
**Challenge Rating:** 4  
**Construction Time/Cost:** 4 weeks; 4,000 gp

This is a fairly basic trap that relies on the undetectable nature of a poison gas. The trap begins with a corridor that slopes downward and leads to a door. Beyond

the door the corridor extends for around 100 feet, continuing to slope downward slightly. It then slopes back up at its midpoint, eventually leading to another door. The corridor between the two doors is filled with pooling breather poison. Though this poison is not particularly potent, the advantages of transparency, long life, and lack of odor are significant.

Since the corridor is tilted, the party enters the poison as if entering pooled water. The first indication of trouble will be from the shortest members then up to the tallest. Also, regular torches and lanterns (but not *continual flame*) will gutter out once they are immersed in the gas. Undead or other beings that do not require oxygen are unaffected.

Torches may be the first signs of trouble if they are held low and thus encounter the gas first. Familiars and other animals close to the ground are also affected before humanoids.

Once immersed in the gas, the initial effect is shortness of breath. The first Fortitude save and poison effect kick in at this point. If the character retreats to fresher air and takes deep breaths, the gas can be cleared from the lungs. If a character passes out while in the gas, suffocation effects proceed.

There is no distinct way to disable this trap. The locked door has three good locks on it, each requiring a successful Open Lock check (DC 30) to bypass. Once open, a character can simply hold her breath and run through. An easier method would be two applications of *knock*, cast while outside the effect of the poison. The boundaries of the gas can be determined with a flame.

When the door is open, a *gust of wind* can be used to push the gas out and dilute it. After a few minutes, the gas pools again, but only at half the length it covered before. Another gust brings the distance to a third of the original. No further gusts significantly disperse the gas.

There are magic sigils near the door that, when the gas is diluted, open valves near the ceiling, replenishing the trap automatically. This is not a quick process, and the reservoir of gas is limited. Filling the hall from one-third length to full takes about a day. Though these sigils may alarm characters who notice them (Search DC 30), this is their only function. If dispelled, the corridor simply does not refill with gas.

The Breathtaking Corridor is most effective when combined with undead guardians. With a turn in the hallway below the gas line, undead can also be protected from ranged attacks. Combined with a permanent *animate dead* and *magic mouth* (such as in the Tomb of Perennial Guardians trap from *Traps & Treachery*), the system can function for quite some time.

Tombs or lairs of undead are both useful locations for such a trap. Dwarves may also set up these corridors as access tunnels, relying on hearty constitution and their innate resistance to poisons. A dwarf may be able to hold her breath a long time while passing through these areas, and is unlikely to be carrying an open flame because of his darkvision.

DMs gathering information on the height of party members might want to make a point of doing so well before the party encounters this trap. Another trap that seems height related could misdirect suspicions about the intent of gathering such information.

There are other variations using different gases, though the design relies on the substance being heavy and inert. One form in dwarven mines uses the corridor as a metalseep gas catch basin. There is no middle door in this version. Air flows through the bent corridor, warm from passage through concentrated amounts of firemetal. Airflow is sluggish, allowing the heavier metalseep gas to sink into the corridor. Though not always intended as a trap, it can be placed to induce such an effect. There is no obvious effect of gas exposure, making this a particularly subtle attack. Only one Fortitude check is required per visit unless the character dawdles. Such a trap has a Challenge Rating of 3.

## DARKMETAL CLAWTRAP

**Trap Type:** Bladed Snare Trap  
**Construction Type:** Complex mechanical  
**Activation Type:** Instant  
**Trigger:** Local; switch  
**Mechanism:** Spring, gears  
**Effect:** Ensnarement, injury  
**Attack Bonus:** No attack roll necessary  
**Damage:** 2d6  
**Save:** Reflex save (DC 25) avoids  
**Search DC:** 25  
**Disable Device DC:** 25  
**Challenge Rating:** 4  
**Construction Time/Cost:** 4 weeks; 4,000 gp

The Darkmetal Clawtrap appears as an ornate doorlock. Bands of metal radiate from it along the door. One piece of the lock is made of a metal that changes shape in the presence of light. Anyone attempting to operate the lock, whether to pick it open or even using a proper key, activates the trap if light is hitting this sensor.

The door requires a Strength check (DC 35) to break down. Disabling the lock is difficult, but not impossible (Open Lock check DC 25). It is somewhat easier if the character knows of the properties of light sensors (Craft (trapmaking) check DC 29), making it DC 21.

The radiating metal bands snap out and close like jaws when the trap goes off. A character gets a Reflex save to pull his hand away in time. Failure causes 2d6 points of damage, and leaves his hand caught by the jaws. Harmlessly extricating a hand from the claw requires an Escape Artist check (DC 30). The check succeeds with a result of 20 or more, but the character takes 1d6 points of damage when freeing his hand. Failure results in 1d6 damage without extrication.

In total darkness, the key operates normally. Failure to properly open the lock still triggers the trap, however. Note that once activated, the trap is manually reset. In addition, the lock cannot be accessed without resetting the mechanism.

The trap requires some maintenance, both to fix any damage to the mechanism and to remove any victims that did not survive it.

## FIELD OF RUIN

**Trap Type:** Siege Trap  
**Construction Type:** Magic  
**Activation Type:** Magic  
**Trigger:** Special  
**Mechanism:** Magic  
**Effect:** Hindrance  
**Attack Bonus:** No attack roll necessary  
**Damage:** None  
**Save:** None  
**Search DC:** Special  
**Disable Device DC:** 31  
**Challenge Rating:** 4  
**Construction Time/Cost:** 6 days; 3,000 gp; 120 XP

It is said that an army travels on its stomach. Supply lines make or break an army whether it is on the move or encamped for a siege far

away from home, especially in the winter months when foraging yields poor results.

The Field of Ruin is a large-scale magical trap that strikes at the belly of an invading force. It consists of four large standing stones, positioned in a rough square centered on an area a passing army is likely to march through, such as a road, ford, or mountain pass. The stones, perhaps a mile from one another, are often disguised in some way to mask their function when examined by enemy patrols and advance skirmishers. The stones are often disguised as the centerpiece of a shrine, hidden inside barns or caves, or secreted in thickets or bogs.

Detecting the trap is more than a matter of discovering a single stone; the runes engraved on a lone stone suggest merely that those who erected it were seeking some magical effect. As more stones are unveiled, however, a clearer picture of their function emerges. The Search difficulty for locating and identifying this trap therefore decreases as more of the stones are found: the Search DC for one stone is 40; for two stones 35; for three stones 30; and for all four it drops to 25.

The trap is magically attuned to some attribute its constructors fear in a likely enemy. When a sufficient number of beings with that attribute enters the circle of stones, the trap triggers, magically befouling all food and water carried by the offending beings. Food decays or becomes inedible slime, while water turns to seawater.

The Field of Ruin continues to function until it no longer detects the requisite number of enemy, then goes dormant once again. In this way, an entire army might pass through the stone circle over a two-hour period and lose its entire food and water supply. It could be hours before company commanders become aware of the problem, increasing the difficulty of determining where the army encountered the trap.

Those who erect the trap set the attribute to which the trap is attuned and the number of beings bearing that attribute that must enter the Field of Ruin to trigger it. A small kingdom plagued by goblin attacks may set their trap to activate when a group of 40 or more goblins enters the Field of Ruin. A large kingdom fearing attack by a neighboring empire may set it to activate only when a group

of 300 or larger enters, regardless of their race or composition.

Disarming the Field of Ruin requires locating at least three of the stones and chipping the runes and sigils away. The stones then lose their potency and the trap is ruined. Casting *purify food and water* restores spoiled supplies within the range of the spell.

The Field of Ruin is obviously most devastating in areas where replacing spoiled food and water is difficult. Deserts, tundra, and desolate steppes all make excellent choices. Most settlements using the Field of Ruin are careful not to place it too close to its farms and villages. Doing so would only encourage enraged invaders to take it out on their people and strip them of the resources they need to survive.

The Field of Ruin is not merely a defensive trap. One creative team of clerics mounted a daring expedition to plant a Field of Ruin on the bottom of an enemy's harbor just before a critical grain shipment arrived, plunging the kingdom into famine and forcing it to sue for peace.

## FLIP CORRIDOR

**Trap Type:** Pit Trap  
**Construction Type:** Complex mechanical  
**Activation Type:** Instant  
**Trigger:** Local; pressure, switch  
**Mechanism:** Counterweight, gear, gravity  
**Effect:** Ensnarement, injury  
**Attack Bonus:** No attack roll necessary  
**Damage:** 3d6 or 5d6  
**Save:** Reflex save (DC 26) avoids  
**Search DC:** 22  
**Disable Device DC:** 22  
**Challenge Rating:** 4  
**Construction Time/Cost:** 4 weeks; 4,000 gp

This 20-ft. section of corridor is actually a separate structure, set up on an axis. It is locked in place with a relatively simple two-step mechanism. Each end of the corridor has a trigger based on weight. If an end receives 150 lb. or more, the trigger is released. The trap is sprung when both triggers have opened.

The corridor moves only slightly during triggering, but it is perceptible (Spot check DC 15). Due to the design of the trigger, a character could step into the corridor, back off,

and step back in again without having any obvious effect.

Once the character reaches the opposite side, even by moving a small distance from the midpoint, the second trigger is released. A single individual weighing at least 150 lb. needs to reach the opposite end of the corridor for this to happen.

Each trigger releases a ratchet holding the axis in place. When both are released, the weight of its occupants swings the corridor to a vertical alignment. Once this happens, another mechanism slowly pulls the corridor back to a horizontal position and locks it in place.

The corridor is bare and with a surface of solid marble. Magic combined with expert craftsmanship provides a surface with no features on which to hold. It is somewhat slick, though it provides decent footing when walking through it. Once the corridor is vertical, however, the surface provides insufficient friction for anything short of magic.

A character may only take free actions before the room spills onto its side, and it requires a Concentration check (DC 20) to cast quickened spells. If the character is within a few feet of either end, he may make a Reflex save (DC 26) to escape the corridor; otherwise no save is allowed.

The pit is 30 ft. deep and has a locked service entrance. That door requires a Strength check (DC 30) to batter down, as it has no visible lock mechanism on the pit side.

Damage from the fall depends on where the character is when the corridor goes vertical. Base damage is 3d6 points for falling into the pit, +1d6 per 10 feet of corridor through which the character falls. Note that the corridor can swing in either direction, depending on which direction the characters were traveling when they triggered the trap.

The corridor may have an external lock mechanism in a remote location so that inhabitants can use the corridor without trouble. This lock simply bolts the corridor in place, so the mechanism does not register any pressure.

A perceptive character might note the slight gap along the ceiling and walls at either end of the corridor section. Furthermore, the gap

along the walls is distinctly curved, giving the character a possible clue as to function. A character with Knowledge (mathematics) or a similar skill can calculate the probable length of corridor that is mobile. Similarly, once the corridor is actually entered, the corridor moves slightly down under the pressure.

Disarming the trap is a simple matter of carefully spiking the gap along the floor and ceiling. If only the floor is spiked, the far side of the corridor still triggers, but without any visible result. The danger is that at this point, the wedges have been worked loose, so when the party returns in the other direction, the other trigger activates when they cross back over the midway point. If only the ceiling is spiked, the wedges work themselves loose once the party enters the corridor. This will be rather obvious, but may have no visible result.

This trap is useful in lairs and fortresses of various kinds, not only underground. It has a number of mechanical parts that need attention. The reset mechanism is a little delicate, and may require parts to be replaced or greased to work properly. The Flip Corridor's largest advantage is that there is no need for a source of energy, as motion ultimately comes from the victims. Though the trap can get stuck open, under rare circumstances, its mechanism is at rest when ready to be triggered.

Access tunnels and rooms flank the corridor so artisans and trapmakers can access the parts. If the corridor does not have a normal lock to bolt it in place, the system can be locked down manually in these side rooms.

## FRAGMENTATION BOOK

**Trap Type:** Item Trap  
**Construction Type:** Simple mechanical  
**Activation Type:** Instant  
**Trigger:** Local; light sensor  
**Mechanism:** Spring  
**Effect:** Injury  
**Attack Bonus:** No attack roll necessary  
**Damage:** 4d6  
**Save:** Reflex save (DC 20) avoids  
**Search DC:** 27  
**Disable Device DC:** 21  
**Challenge Rating:** 4  
**Construction Time/Cost:** 4 weeks; 4,000 gp

This is a popular way to trap books that does

not involve magic. Light sensitive metal is crafted into numerous slivers and affixed to a thin sheet of vellum. Another sheet is then glued to the surface, forming a new sheet only slightly thicker than usual. This page is combined with others to be bound in the final book. The entire process is completed in darkness to reduce the risk of mishap.

When anyone opens the book to that page in lit surroundings, the trap goes off. Light penetrates the thin surface of vellum. The metal snaps into new shapes because of the light, causing an explosive effect. Numerous sharp bits of metal are thus sprayed into the face of the reader, dealing her 4d6 points of damage. A successful Reflex save halves this damage.

This trap also deals some damage to the pages above and below the trapped page, so owners tend to place unimportant text on the pages bracketing the trap. This is one of several possible clues to the presence of the trap. Another potential clue is that users of such books often use weak glue to keep the page from being accidentally exposed during normal use. Characters familiar with traps should understand what these clues signify.

To disarm the fragmentation trap, a character must first identify the likely page or pages to be trapped. They can then be examined by touch, but only while in darkness. The stiff outlines of the metal in the page are obvious, and serve to confirm the nature of the page. All that remains is to cut out the page in question, or to seal the pages around it more firmly.

Some variants of this trap keep thieves guessing. One in particular uses a spring design, so that the effect is triggered by cutting the page or bending it more than 20 degrees from its natural direction in the book. Since bending a page is a common way of checking to see if it has a Book Blade trap, this mechanism particularly preys on thieves only familiar with the normal version of the trap.

Mages often use this trap in combination with a more conventional magic trap. The logic is that anyone capable of detecting and dispelling the first trap will not expect a non-magical trap. Since this trap has become common in some regions, this expectation is no longer the case. Still, it is difficult for any one person to handle both a magic and mechanical trap.

Fragmentation book traps have also seen use with other items, often placed on the inside of some container. These trapped items are placed specifically to harm thieves, as the presence of the trap pretty much precludes normal use of the item. It can also be used as a method of assassination, such as affixing these fragments to the inside of a gift box.

## HAVE A SEAT

**Trap Type:** Teleport Trap  
**Construction Type:** Magic  
**Activation Type:** Instant  
**Trigger:** Local; magic  
**Mechanism:** Magic  
**Effect:** Movement  
**Attack Bonus:** No attack roll necessary  
**Damage:** None  
**Save:** Will save (DC 19) negates  
**Search DC:** 30  
**Disable Device DC:** 30  
**Challenge Rating:** 4  
**Construction Time/Cost:** 4 days; 4,500 gp; 120 XP

The magus Therimin never cared much for guests of any sort and devised dozens of fiendish ways to deal with them. One of his favorite tricks involved a comfy chair and a nearby swamp. Therimin liked to think about the dawning moment of confusion his victims felt just before they took a bath in the grimy waters.

Just touching the chair does not activate the trap. A victim must completely sit down and rest against the back of the chair to trigger it. Anyone sitting in the chair when the trap triggers must make a Will save (DC 19) or the chair *teleports* the unwanted loafer several miles away and approximately 5 feet above the waters of a swamp.

## JAW GATE

**Trap Type:** Siege Spike Trap  
**Construction Type:** Complex mechanical  
**Activation Type:** Instant  
**Trigger:** Remote; switch  
**Mechanism:** Counterweight, gears  
**Effect:** Hindrance, injury  
**Attack Bonus:** +15 melee  
**Damage:** 4d6  
**Save:** Reflex save (DC 16) avoids  
**Search DC:** 24

**Disable Device DC:** 24

**Challenge Rating:** 4

**Construction Time/Cost:** 4 weeks; 4,000 gp

Battering rams are the bane of every besieged city and keep; once the settlement's gate doors are breached, defending it becomes much more difficult. Jaw Gate is a siege trap designed to confound the battering ram before it can do its damage.

Built around an opening that is located within a gate tower, the Jaw Gate consists of a cluster of huge iron spikes that slide from holes within the walls of the gate tower to catch the battering ram as it strikes the gate (the spikes hit the ram five to 10 feet behind its tip). Guards within the tower activate the trap by pulling a lever. The lever releases a series of massive counterweights hidden within the walls of the gate tower. Driven by the counterweights, a network of gears propels the spikes out from the walls of the gate's interior, causing them to bite deep into the ram or other war machine.

Since the guards wait until the ram has struck the gate itself, there is no opportunity for those handling the ram to steer it clear of the trap; the spikes are too quick for that. Freeing a spiked ram requires its wielders to hack away the wood surrounding the spikes and wrest the ram free. The counterweights can be reset and the spikes retracted in 15 rounds, allowing them to menace invaders again; but defenders rarely retract the spikes when a ram is caught fast.

Though not intended to target individuals, the spikes inevitably impale some of the soldiers manning the ram. While there are a dozen spikes on either side, they are spaced out considerably, and no more than two can strike a single person.

The spike holes are sealed with wooden plugs in peacetime, though no effort is made to conceal them. Deducing the presence of the trap is therefore not all that difficult for someone, as long as they are given a few moments to examine the inner walls of the gate tower. The trap may be activated with the plugs in, but it deals only half damage in this case.

Disarming the trap requires access to the trap machinery located in the bowels of the gate tower. (Note that there are two trap mechanisms, one for each inner wall of the gate tower, and they are often located in separate

rooms.) A would-be saboteur must bypass both the gate and its guards to get to the trap mechanisms. Smashing the gear assemblies or cutting the chain connecting them to the counterweight is the easiest way of disarming the trap. There is no way of disarming the trap from the gate area itself.

Though city officials frown on the casual use of the Jaw Gate, they are equally effective in stopping wagons and carriages barreling through the gate; more than one fleeing noble or criminal has been stopped by this trap.

## PALADIN'S BANE

**Trap Type:** Corrosive Dust Trap  
**Construction Type:** Complex mechanical  
**Activation Type:** Instant  
**Trigger:** Local; switch  
**Mechanism:** Pressure  
**Effect:** Hindrance  
**Attack Bonus:** No attack roll necessary  
**Damage:** None  
**Save:** Reflex save (DC 20) avoids  
**Search DC:** 22  
**Disable Device DC:** 25  
**Challenge Rating:** 4  
**Construction Time/Cost:** 4 weeks; 4,000 gp

This trap uses a pressurized blast of air to disperse a cloud of alchemical dust from a disguised nozzle when a switch is triggered. The dust, created from the antennae of a rust monster, cause metal to dissolve into rusted flakes.

This trap is most commonly built into a bas relief sculpture above a wood or stone door that acts as the switch. Opening the door, even slightly, releases a cloud of dust that fills a 5-ft. space on each side of the door. Creatures within this area must make a Reflex save (DC 20) to escape the dust as it hisses from its hidden outlets. Any creature that fails its Reflex save is covered in dust, causing exposed metal to corrode and fall to pieces, becoming useless immediately. Magic armor, weapons, and other items made of metal must succeed at a Reflex save (DC 20) or be dissolved. Wood, stone, and other nonmetallic materials are unaffected.

A successful Search check allows a perceptive creature to notice the nozzle hidden within the intricate sculpture. Further investigation identifies the door as the switch that pulls a hidden pin when opened. Disarming the trap requires

the pin to be disconnected from the door before opening it. Jamming the nozzle only disables the trap's effects on one side of the door.

Creating the corrosive dust used in this trap requires a pair of rust monster antennae that have been separated from the aberration for less than two days and a successful Alchemy check (DC 35). Some alchemy shops in larger cities may have, or be able to create, this substance at a market price of 550 gp. The price of the corrosive dust is included in the initial construction cost.

## PERIVAX'S CRUSHING BANDS

**Trap Type:** Spring-Loaded Door Trap  
**Construction Type:** Simple mechanical  
**Activation Type:** Instant  
**Trigger:** Local; switch  
**Mechanism:** Spring  
**Effect:** Injury  
**Attack Bonus:** No attack roll necessary  
**Damage:** 4d6  
**Save:** Reflex save (DC 20) avoids  
**Search DC:** 22  
**Disable Device DC:** 22  
**Challenge Rating:** 4  
**Construction Time/Cost:** 4 weeks; 4,000 gp

Perivax's Crushing Bands is a simple door trap that is used by nobles to punish trespassers and meddlesome thieves.

This trap can be found in any type of stronghold, dungeon complex, or crypt. Although the original design came from the mad trapsmith Perivax, this trap has made its way across several continents, along with several variations that have been developed over the years. One popular variation for this trap is the use of odorless contact poisons coating the iron bands.

The trap itself appears to be a large, reinforced door. The materials used to construct the door are left to the builder, the only similarity being the use of four heavy iron bands that are joined together by a central band on the door. While appearing as reinforcement for the door, the bands serve a more sinister purpose.

Any character attempting to open the door activates the trap. As the doorknob is jarred, a series of simple mechanisms within the door activate to release all four of the highly tensioned, spring-loaded iron bands to



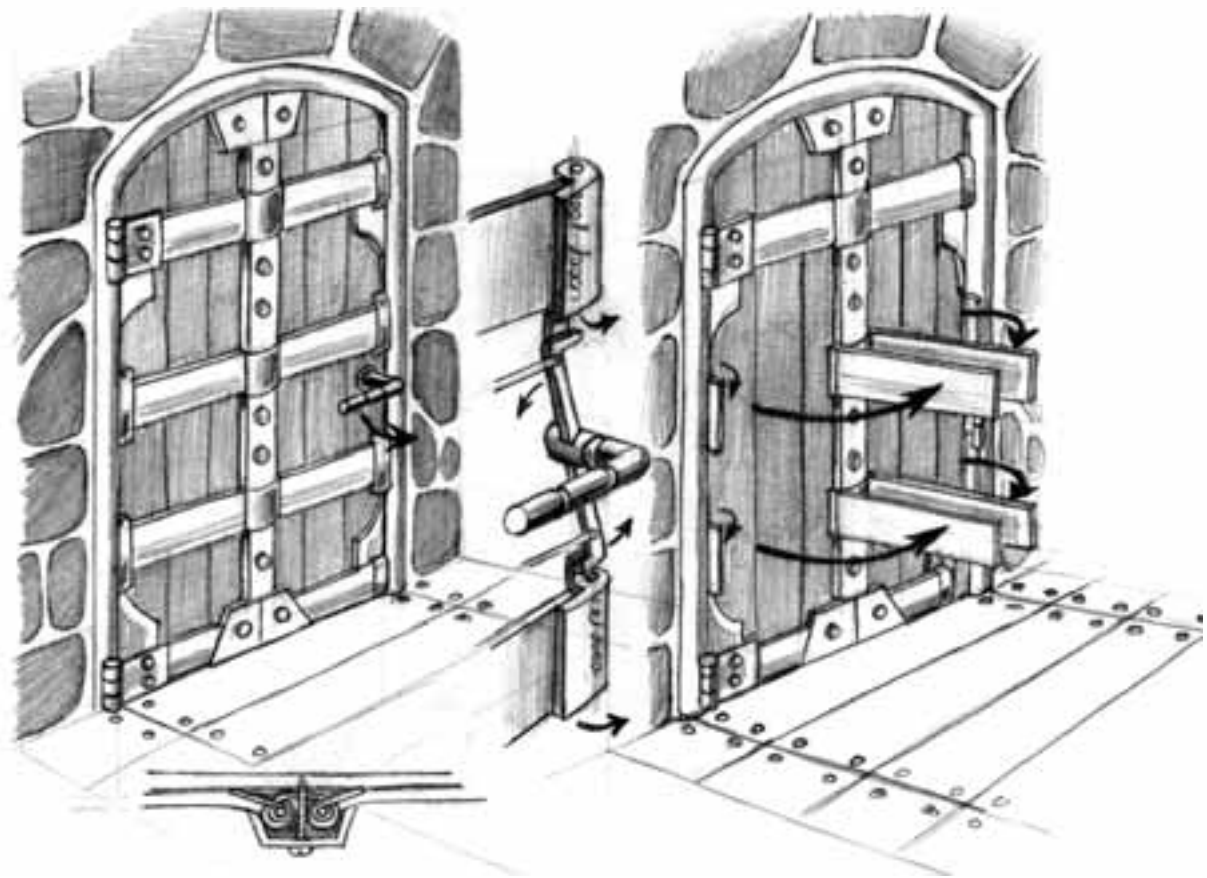

crush the unsuspecting character. A successful Reflex save (DC 20) allows a character to avoid the four bands as they crash together. If a character fails to avoid the iron bands, she suffers 4d6 points of damage and is considered pinned within the bands. A successful Strength or Escape Artist check (DC 20) is required to escape the bands. For every round a character is trapped within the iron bands she suffers an additional 1d6 points of damage.

This is a one-use trap and must be reset manually with a successful Strength check (DC 22).

An observant rogue may easily notice the subtle latching on the outer rim of the door that holds the iron bands in place. Additional signs may be the faint smell of the oil used to keep the iron bands at their peak performance, or the faint traces of blood on the iron bands from an improper cleaning.

## RAZOR MESH

**Trap Type:** Door Trap  
**Construction Type:** Complex mechanical  
**Activation Type:** Instant  
**Trigger:** Local; switch

**Mechanism:** Pressure, gear, counterweight  
**Effect:** Injury  
**Attack Bonus:** No attack roll necessary  
**Damage:** 4d6  
**Save:** Reflex save (DC 20) partial  
**Search DC:** 25  
**Disable Device DC:** 25  
**Challenge Rating:** 4  
**Construction Time/Cost:** 4 weeks; 4,000 gp

A fancy door trap, the Razor Mesh has two components. The first is a simple locked door. Whether it is unlocked or picked open, opening the door triggers the second stage. As the door opens, machinery causes razor-sharp thread to spool through the doorway at increasing speeds. By the time the door is fully open, the tiny threads are moving too quickly to see, so the only clue that something is going on is a faint whirring and then whining sound.

Anyone entering the doorway takes 4d6 points of damage, 2d6 if a Reflex save (DC 20) is made. In either case, the character is assumed to withdraw from the doorway. If the character is pushed forward or otherwise unable to move away, the character takes 8d6 additional points of damage per round until he can back out of

the door. After one minute, the device runs out of power and the threads go slack, becoming visible and easily bypassed.

Sticking an iron bar or similar implement into the doorway while it is running will cause the device to break. It requires a Strength check (DC 20) to keep a hold on the bar. If failed, a Reflex save (DC 18) is needed to avoid taking 2d6 points of damage as the bar jerks out of the hand.

When the mechanism has wound down, an iron bar or weapon can be used to break the strands.

The key to deactivating the trap is a pressure switch in a nearby wall. When pressed, the mechanism either fails to begin spooling or, if already activated, deactivates and resets. While inactive, the threads move out of the doorway, leaving it open to be walked through. Disarming the trap merely requires the thief to wedge the pressure plate in, preventing the trap from activating.

Once the door is closed again, the mechanism resets. It requires a fairly sophisticated mechanism to function, usually treated through a combination of alchemy, craft, and magic. Ultimately it relies on a counterweight to provide the drive for each cycle. Particularly advanced mechanisms may use a power source to provide longevity to the trap without requiring regular maintenance

## SNARE TOSS

**Trap Type:** Snare Trap  
**Construction Type:** Complex mechanical  
**Activation Type:** Instant  
**Trigger:** Local; tripwire  
**Mechanism:** Counterweight, spring  
**Effect:** Ensnarement, injury, movement  
**Attack Bonus:** No attack roll necessary  
**Damage:** 4d6  
**Save:** Reflex save (DC 16) avoids  
**Search DC:** 22  
**Disable Device DC:** 22  
**Challenge Rating:** 4  
**Construction Time/Cost:** 4 weeks; 4,000 gp

Effectively using a catapult as a trap, the major difficulty encountered by users of the Snare Toss is in hiding the arm of the device. There are several versions, following along the lines of various designs of catapult. The version pre-

sented uses a counterweight as the primary mechanism.

A snare is set near the tripwire, some distance from the arm of the device. When the wire is pulled, the arm is released. The loop of the snare catches the character if he fails a Reflex save (DC 16) and the rope closes around his leg. A slipknot helps secure the loop as the character is yanked through the underbrush and up into the air. The character arcs over the device and then slams into the ground on the opposite side. Though still caught in the snare, it requires no roll to loosen the loop and get free. The character takes 3d6 points of damage from a combination of the initial acceleration, collisions with bushes and other growth, and the final impact.

The Snare Toss is a simple and deadly device, though not built on the same scale as siege engines. A war-quality catapult built in this way would kill just about anyone it caught, and probably rip the victim's leg off in the process. This version is much smaller and not nearly as lethal. However, being smaller, it is significantly easier to hide than a towering war machine.

Spotting the tripwire is fairly easy for a skilled thief, though in overgrown areas it may become harder (as per the outdoor trap rules). The arm can be disguised as a dead log and placed a distance away, but the deception is tricky. Once identified, the design of the switch is fairly obvious through direct examination. The tripwire is fairly simple, requiring a pulling action to release the switch. Though there are sophisticated designs that keep a tripwire under tension and cause it to fire when it is cut, such designs work poorly in the wild. Simply cutting the tripwire foils this design, but care is needed to avoid pulling at the string when doing so.

Despite the term "tripwire," this trap can be made without any metal parts. Since it does not need to be taut, the tripwire can be made out of coated string or other materials. The primary components can be designed from bone, treated wood, and rope.

Resetting the trap is a fairly simple matter of pulling the arm back into place. This can be accomplished with a draft horse or ox, a few men, or a winch. Outdoors, this activity negates the benefits of Wilderness Lore in

hiding an outdoor trap. Scarejuice is normally applied to prevent animals from triggering the trap. The rope and other materials require maintenance every few months, and an outright overhaul after six months, due to exposure to elements. In particularly dry and mild climates, the short-term maintenance is required every four months, and an overhaul once per year.

The Snare Toss can be modified in a number of ways to make it significantly more deadly. Spikes placed in the drop location can increase damage. Poison may be interesting, but is a bit impractical for long term outdoor use. A catch can be employed to release the victim at the height of the arc, making the device more like a siege engine. This will normally do less damage, but can be used to toss a character off a cliff.

## SPIKED STAIRS

**Trap Type:** Impalement Trap  
**Construction Type:** Simple mechanical  
**Activation Type:** Instant  
**Trigger:** Local  
**Mechanism:** Gravity

**Effect:** Injury  
**Attack Bonus:** No attack roll necessary  
**Damage:** 6d6  
**Save:** Reflex save (DC 23) for half  
**Search DC:** 24  
**Disable Device DC:** 20  
**Challenge Rating:** 4  
**Construction Time/Cost:** 4 weeks; 4,000 gp

This is a fairly simple trap that is usually set up in likely avenues of exploration, and in areas that the inhabitants of the complex know to avoid. Built into staircases, this trap offers considerable pain to those who blindly rush ahead when they see a staircase.

The mechanism is simple. Weakened boards or stones held together with weak concrete are set in the center of a staircase. When someone charges up or down the stairs, the false stairs break, dumping the victim onto the spikes below.

Disabling this trap requires somehow reinforcing the weakened portion of the stairs, or building a bridge over the trapped area.

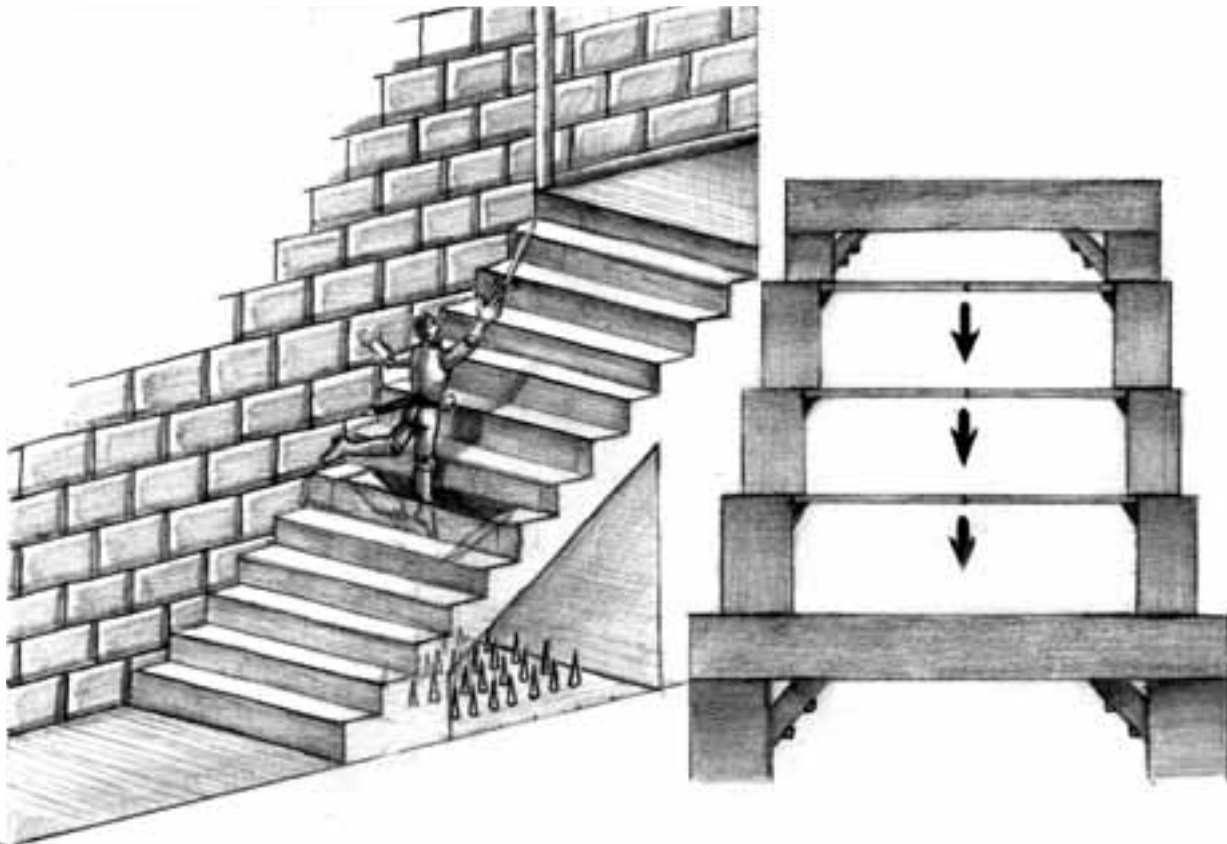

Noticing the weakened construction or hearing an odd hollowness upon taking a first step onto the stairs can give away this trap.

## SPINDLE SPRAYER

**Trap Type:** Fountain Poison Trap  
**Construction Type:** Complex mechanical  
**Activation Type:** Instant  
**Trigger:** Local; magic  
**Mechanism:** Magic  
**Effect:** Hindrance, identification  
**Attack Bonus:** No attack roll necessary  
**Damage:** Poison  
**Save:** Fortitude save (DC 14) resists  
**Search DC:** 24  
**Disable Device DC:** 21  
**Challenge Rating:** 4  
**Construction Time/Cost:** 4 weeks; 4,000 gp

This trap is easily built into fountains and other ornaments. It consists of a rod over which a fluid is poured. A pump, either conventional or magical, keeps the fluid circulating from the catchbasin to the top of the rod.

One spectacular design involves a solid gold fountain, set with magic lights that project through jewels set in the base. The jewels are set in the gold. Most thieves assume that one or more of the jewels are triggers, but actually the fountain base itself is a pressure plate. If someone steps within 5 feet of the fountain, the trap is triggered.

The mechanism is quite simple. The fluid pouring over the rod is mouthing eyes poison in a water solution. When activated, the rod starts spinning rapidly. The small bumps and ridges of the rod serve as launching points, causing the fluid to spray in all directions. Anyone within the area is likely to get a face full of the poison.

The trap also engages an alarm, letting nearby guards know that someone approached the fountain.

Observant characters may note that the area around the fountain shows little wear. In addition, the block around the fountain shows suspicious gaps in the stonework. A standard spiking along the pressure area, preventing the fountain's base from lowering, can disable the trap.



This trap requires a fair amount of care and maintenance. Mouthing Eyes poison is fairly stable, but even so, it has to be refreshed every few days to keep the potency high. Other poisons can be substituted, but some do not function well in this design. Pumps powered by waterwheels can be long lasting, but still require periodic cleaning.

## STILTED WALL

**Trap Type:** Siege Wall Trap  
**Construction Type:** Complex mechanical  
**Activation Type:** Instant, remote  
**Trigger:** Switch  
**Mechanism:** Spring  
**Effect:** Hindrance  
**Attack Bonus:** +8 melee  
**Damage:** None  
**Save:** Reflex save (DC 20) avoids  
**Search DC:** 25  
**Disable Device DC:** 25  
**Challenge Rating:** 4  
**Construction Time/Cost:** 4 weeks; 4,000 gp\*

\*Modifying an existing wall raises the price considerably.

The Stilted Wall is a siege trap designed to cast down the ladders of invaders seeking to scale the walls of a castle or city. Like most siege traps it is triggered by the wall guards, who spring the trap at the optimal moment.

The Stilted Wall is not difficult for the trained eye to detect. Its outer component, an iron-sheathed wooden crossbar that runs horizontally along the length of the wall is in plain view. Those unfamiliar with the Stilted Wall trap may suppose it to be mere ornamentation, of course.

A lever located in a secure guardhouse within the upper wall complex triggers the trap. Pulling the lever releases a series of powerful springs, which then drive the pistons that are attached to the crossbar out with great force. The crossbar springs 20 ft. from the wall, casting down ladders, ropes, and the men on them. It can then be withdrawn and reset via a rotary winch, ready to go again in 20 rounds.

Disarming the Stilted Wall involves infiltrating the guardhouse and damaging the trap mechanisms from within. Scaling the outer wall and spiking the crossbeam shut, either physically or magically, is theoretically possible, though the means of securing it would have to be quite powerful; the crossbar springs with a Strength of 40 and counts as a Large creature. After the trap is sprung it is more susceptible. The metal pistons, with 15 hit points and a hardness of 10, can be hammered sufficiently out of shape to make rearming the trap impossible. (Of course, those attempting such a feat must brave the arrows and other missile weapons that speed toward them from all around.) A safer method might be to sling ropes and chains over the extended crossbeam and pull it down with men or horses.

Running a few slats of lumber across an open Stilted Wall trap makes an excellent platform for renewed assaults on the wall, which is its primary tactical drawback.

## SYLVAN SPRINGSPIKE

**Trap Type:** Forest Trap  
**Construction Type:** Complex mechanical  
**Activation Type:** Instant  
**Trigger:** Local; tripwire  
**Mechanism:** Spring, wire  
**Effect:** Injury  
**Attack Bonus:** +10 melee

**Damage:** 6d6  
**Save:** None  
**Search DC:** 25  
**Disable Device DC:** 21  
**Challenge Rating:** 4  
**Construction Time/Cost:** 4 weeks; 4,000 gp

Not all security measures are placed indoors. Trapmakers may want to prevent intruders from passing through an area, approaching a settlement, or escaping a territory. In addition, many races spend the vast majority of their lives outdoors, making the development of outdoor traps a common affair.

The Sylvan Springspike trap can be built both by those who work with metal and those who disdain it. The design is fundamentally the same, regardless of the material used. The default trap centers on a tree and a gap of about 8 ft. on one side of the tree. It is ideal if a path leads through the gap, or passage is somehow otherwise restricted to only it. At the same time, it should not be too obvious that travelers are being directed in any way.

A tripwire is laid across the intervening space, connected to a panel on one side of the tree. The panel acts as a catch for the three wooden spring arms at the base of one tree. Pulling the tripwire yanks the panel down and releases the arms. The arms are each bent back under tension, and move away from the tree with great speed. Each is covered with a number of long teeth (either animal teeth or spikes of metal). Anyone in the gap is subject to the attack. If hit, a character takes 4d6 points of damage.

The metal version of this trap is somewhat easier to notice (Search DC 22). The spikes attack with the same attack bonus, but the damage is higher (increasing to 8d6) due to the material. Metal springspikes are CR 5.

The area around a springspike is usually doused with scarejuice to keep animals from blundering through the trap. This is a possible clue that something unusual is going on. The tripwire and mechanism are somewhat difficult to spot, as per the outdoor trap rules.

Disarming the trap is rather easy once the mechanism is identified. The tripwire can simply be cut, though care is needed to avoid accidentally pulling the wire when doing so.

In addition, traps made of natural materials must be replaced every few months. If conditions are ideal (cool, mild, dry climate), it may only require maintenance once a year. Metal traps are longer lasting. However, the major limiting factor is the scarejuice and the need to reset the trap after each release. The scarejuice lasts a month at most before animals begin wandering through the area.

Poison, particularly foetid paste, is frequently combined with this trap to make it even deadlier. These work best with slower moving arms (so the poison stays solidly on the spike), therefore the damage is less (2d6) but the CR remains the same.

## TENTACLE TERROR

**Trap Type:** Ensnarement Trap  
**Construction Type:** Magic  
**Activation Type:** Instant  
**Trigger:** Local; magic  
**Mechanism:** Magic  
**Effect:** Ensnarement  
**Attack Bonus:** No attack roll necessary  
**Damage:** See below  
**Save:** None  
**Search DC:** 29  
**Disable Device DC:** 29  
**Challenge Rating:** 4  
**Construction Time/Cost:** 1 week; 3,500 gp; 175 XP

Those who dwell in the deep woods have a disadvantage over those who dwell deep in the earth, since there are often many ways to approach their home. However, there are usually some avenues of approach which are more likely than others. The smooth downhill path from the mountain can be watched, the inviting glade can be fitted with snares, and the shallow river crossing can be made much more difficult to cross.

This trap is usually set where a river narrows, offering an obvious crossing point. As with many outdoor traps, the trigger can be deactivated by speaking a passphrase loudly and clearly before crossing the river. Those who do not do so find that their transit is impeded. As soon as one swimmer reaches the midpoint of the river, an *Evard's black tentacles* spell is activated as if cast by a 7th-level sorcerer. 1d4+7 tentacles appear, trying to snare as many of the swimmers as possible.

Detecting this trap is difficult. A rogue might recall tales of such traps from his youth, or he might notice that the stones of the river seem to be laid out in a pattern, as if inscribing a rune on the riverbed. Alternatively, a faint mystical shimmer might hover in the water over the trap.

To disarm the trap, the rogue must dislodge the stones in the riverbed enough to disrupt the magic without setting off the trap.

## THE PLUMMETING ROOM

**Trap Type:** Falling Room Trap  
**Construction Type:** Complex mechanical  
**Activation Type:** Instant  
**Trigger:** Local; switch  
**Mechanism:** Spring, gravity  
**Effect:** Injury, movement, hindrance  
**Attack Bonus:** No attack roll necessary  
**Damage:** 3d6  
**Save:** Reflex save (DC 20) avoids  
**Search DC:** 23  
**Disable Device DC:** 25  
**Challenge Rating:** 4 (+1 for identification feature)  
**Construction Time/Cost:** 4 weeks; 4,000 gp (+1 week and +1,000 gp for identification feature)

This relatively simple but effective trap is best used to protect a tomb or similar area not subject to a great deal of foot traffic. It consists of a normal seeming room, usually no larger than a 20-ft. square, with one other way out in addition to the portal used to enter the chamber. In actuality, the room is a freestanding structure built at the top of a 30-ft. deep shaft, and it is held in place by eight strong beams that protrude from the walls of the shaft beneath the chamber's floor.

Should the door leading out of the room be opened without first disabling the trap, eight powerful springs, each abutting one of the eight support beams, are released. This in turn fires the beams into the shaft walls, leaving the room unsupported and free to plummet 30 ft. to a lower level of the dungeon. Anyone within 5 feet of either door can make a Reflex save (DC 20) to leap to safety. Otherwise, all in the room suffer 3d6 points of damage from the fall. The only way out of the room once it is at the bottom of the shaft is through the ceiling and up the walls. The ceiling is hardness 10, 180 hit points, and break DC 40. If the site

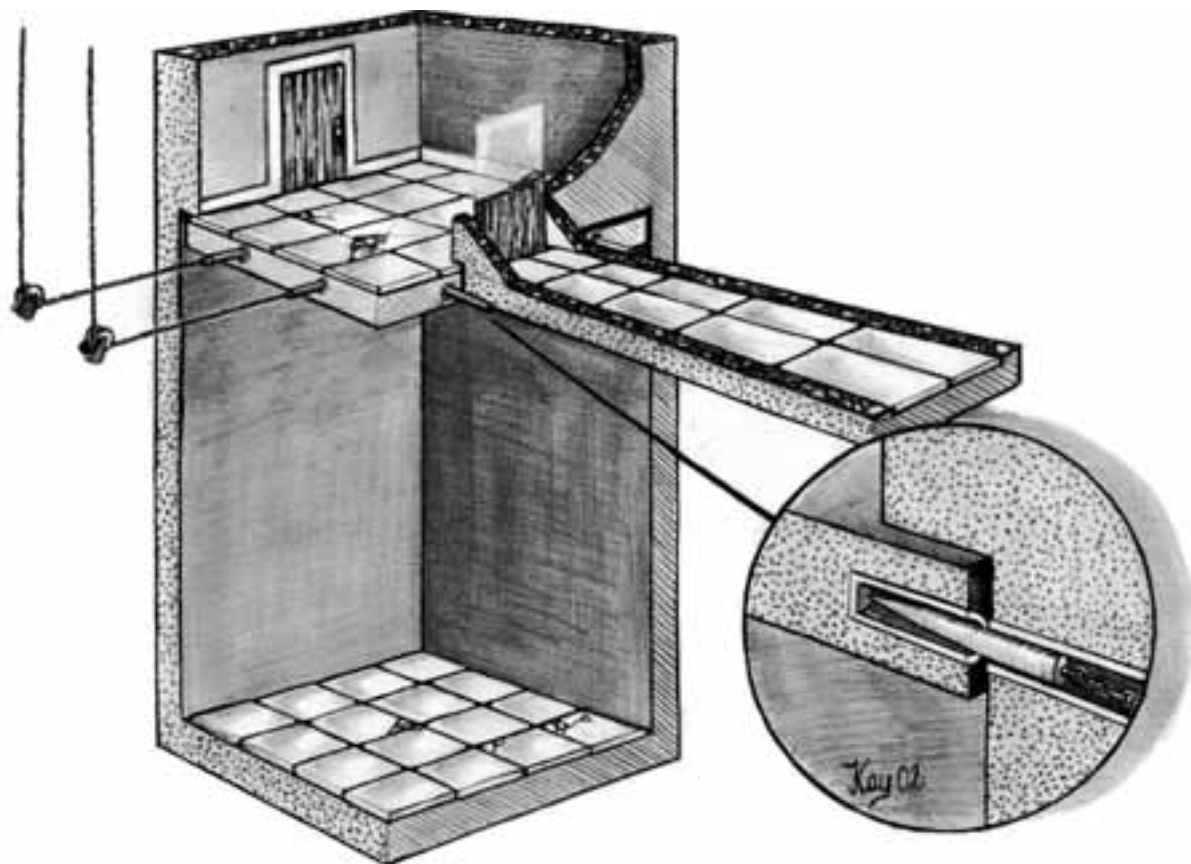

has traditional guardians (golems or other constructs, for example) or lurking undead (especially incorporeal types), they may be alerted by the thunderous crash of the falling room or the shrieks of the characters trapped within.

Some variants of this trap are built so that the doors of the room open up to passageways after the place has fallen to the lower level. In this way intruders can be funneled to more deadly areas of a dungeon or sent to specific guardians who can deal with them before they cause too much trouble.

An alert rogue notices the trigger switch between the bottom of the door and the floor. It is possible, though difficult, to jam the switch into place in order to prevent the springs from firing.

## TRAP KEY TRICK

**Trap Type:** Pit and Alarm Trap

**Construction Type:** Complex mechanical

**Activation Type:** Instant

**Trigger:** Remote; trick lock

**Mechanism:** Gravity, gear, light sensitive metal

**Effect:** Ensnarement, identification, injury

**Attack Bonus:** No attack roll necessary

**Damage:** 2d6

**Save:** Reflex save (DC 20) avoids

**Search DC:** 20 (initial triggers), 24 (middle triggers)

**Disable Device DC:** 25

**Challenge Rating:** 4

**Construction Time/Cost:** 4 weeks; 4,000 gp

One way to greatly increase the effectiveness of a trap is to play on the psychology of potential intruders. In the Trap Key Trick, there are three pressure plates. Two plates are dummied up to look like traps, but actually disarm and rearm the real trap, which is located in between them. The fake traps are pressure plates, relatively easy to spot. The walls facing the trapped area are lined with small holes that look like outlets for poison gas or darts. The false pressure plates can be avoided by walking on the left or right sides of the corridor, or a rogue can simply disarm it. If the pressure plates are tripped, nothing obvious happens.

The middle trap is complex and has two triggers. The first is a simple spring trapdoor. The second is a bell alarm that reverberates

throughout the area, activated by a light sensitive metal trigger. The alarm rings when going from light to dark or the reverse, and is also activated whenever the trapdoor opens. The trapdoor is somewhat straightforward to disable and leads to a 20-ft.-deep pit requiring a Climb check (DC 25) to escape. Painting over or otherwise covering the activation sigil deactivates the light trigger on the alarm.

When the next trap is triggered, it unlocks the entire system. This pattern works both ways. Whichever side is initially triggered becomes the primer, and is unlocked only by the other side being triggered.

This system works well in moderately guarded areas. With heavier traffic and lack of discipline, NPCs frequently create small bridges over the pressure plates to avoid inadvertently triggering the trap.

## TURKEY SHOOT

**Trap Type:** Bridge Trap  
**Construction Type:** Complex mechanical  
**Activation Type:** Instant  
**Trigger:** Local; switch  
**Mechanism:** Spring

**Effect:** Injury  
**Attack Bonus:** +6 ranged  
**Damage:** 1d10 per hit; see below  
**Save:** None  
**Search DC:** 25  
**Disable Device DC:** 25  
**Challenge Rating:** 4  
**Construction Time/Cost:** 6 weeks; 6,000 gp

This fairly complex trap is often used by kobolds in deeper parts of their caves, as it requires considerable maintenance. It also suits the kobold habit of inflicting damage from far away if at all possible.

The trap is set deep in a cave complex. A rope bridge is strung over a deep chasm. The ropes holding the bridge up are fastened to the rock at a variety of odd angles. The bridge seems to be suspended from a spiderweb, an image that ought to give cautious adventurers pause.

Initial steps on the bridge seem safe. It is not until the middle of the bridge is reached that the trap is sprung. Placing pressure on a key rope pulls on other ropes, and, in seconds, dozens of crossbows (usually repeating crossbows) mounted around the cavern fire. The pressure on the rope, combined with intricate gearing

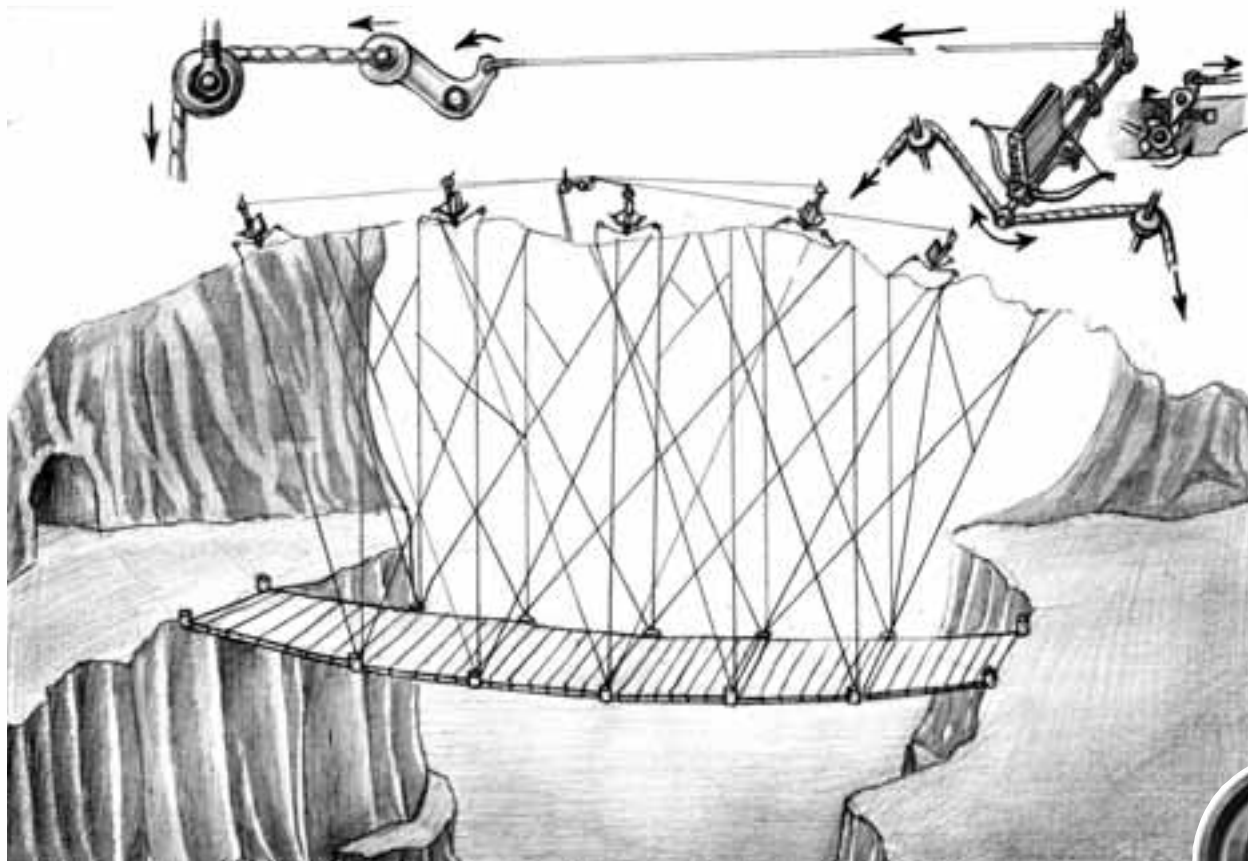



mechanisms, causes the bows to turn and aim towards individuals walking on the bridge. Each time someone moves or runs, the continual tugging of the ropes realigns the crossbows, causing them to track the victims.

On average, so long as anyone is on the bridge after the trap has been triggered, 1d4 crossbows will fire at each person on the bridge, no matter where they move. When the bridge is completely empty, the bolts stop flying.

Detecting the trap involves studying the way in which the ropes cross and intersect, and noticing that most of the ropes are not, in fact, fastened to the walls, but instead go into the walls.

Disabling the trap requires cutting one or two key ropes, which triggers the mechanism.

On occasion, the crossbows are manned instead of being automated. In such a case, use the kobolds' skill to determine attack accuracy, but the firing does not stop when the bridge is abandoned. So long as anyone is visible, the kobolds will keep shooting.

In order to make this trap more lethal for higher-level characters, the crossbows can be magical or loaded with magical (or poisoned) bolts of any sort. Furthermore, characters who take more than 50% of their current hit points in damage from a single hit while standing on a rope bridge might be required to make a Reflex save (DC 15) or plummet to the cavern floor below.

## WALL CRAWLER CHAOS

**Trap Type:** Wall Trap  
**Construction Type:** Simple mechanical  
**Activation Type:** Instant  
**Trigger:** Local; switch  
**Mechanism:** Pressure  
**Effect:** Injury  
**Attack Bonus:** No attack roll necessary  
**Damage:** Falling  
**Save:** None  
**Search DC:** 21  
**Disable Device DC:** 21  
**Challenge Rating:** 4  
**Construction Time/Cost:** 4 weeks; 4,000 gp.

Wall-Crawler Chaos is a simple yet effective trap designed to keep agile trespassers away. By making use of high walls, hidden trigger

stones, and pressure-released sacks of oil, this trap turns an easy climb for a would-be thief into a dangerous and slippery undertaking.

This trap has become very popular among nobles and rulers of well-kept cities who wish to protect against unwanted visitors on their outer walls. This trap is frequently constructed just below the windows and roofs of the highest towers or walls in exclusive manor homes and guildhouses.

The trap itself appears as a normal brick wall or tower wall with the exception of an ornate overhang that protrudes close to one foot below the top of the wall (or window in some cases). Climbing the wall normally requires a successful Climb check (DC 15).

The design of the overhang varies from builder to builder, either reflecting a theme for decoration or simply appearing as some sort of rain gutter. But no matter the appearance, the function remains the same. Hidden within the overhang are a series of wall-mounted wineskins (or similar storage vessels) that each hold several gallons of common oil.

The trap is activated when a character more concerned with scaling a wall than paying attention to details triggers one of the loose stone switches placed into the surface of the wall. The exact number of switches on a particular surface varies from one construction to the next, but on average there will be one switch for every 15 ft. of wall. Once the switch is triggered, a simple pressure mechanism releases the oil stored in the hidden wineskins. The oil cascades quickly down the wall, covering its entire surface. A successful Climb check (DC 20) is required to stay on the wall (The oil increases the DC of the original Climb check by 5).

If a character fails this Climb check, she falls to the ground if otherwise unable to avoid the fall (such as through magic effects, climbing kits, and so on). The climber suffers 1d6 points of damage for every 10 feet she falls.

Several variants of this trap exist, crafted by those who wish to do more harm to potential trespassers. Such notable variants include the use of lantern oil or hot oil that can be ignited by a nearby guard or additional trap component when the trap is activated. Other deadly varia-

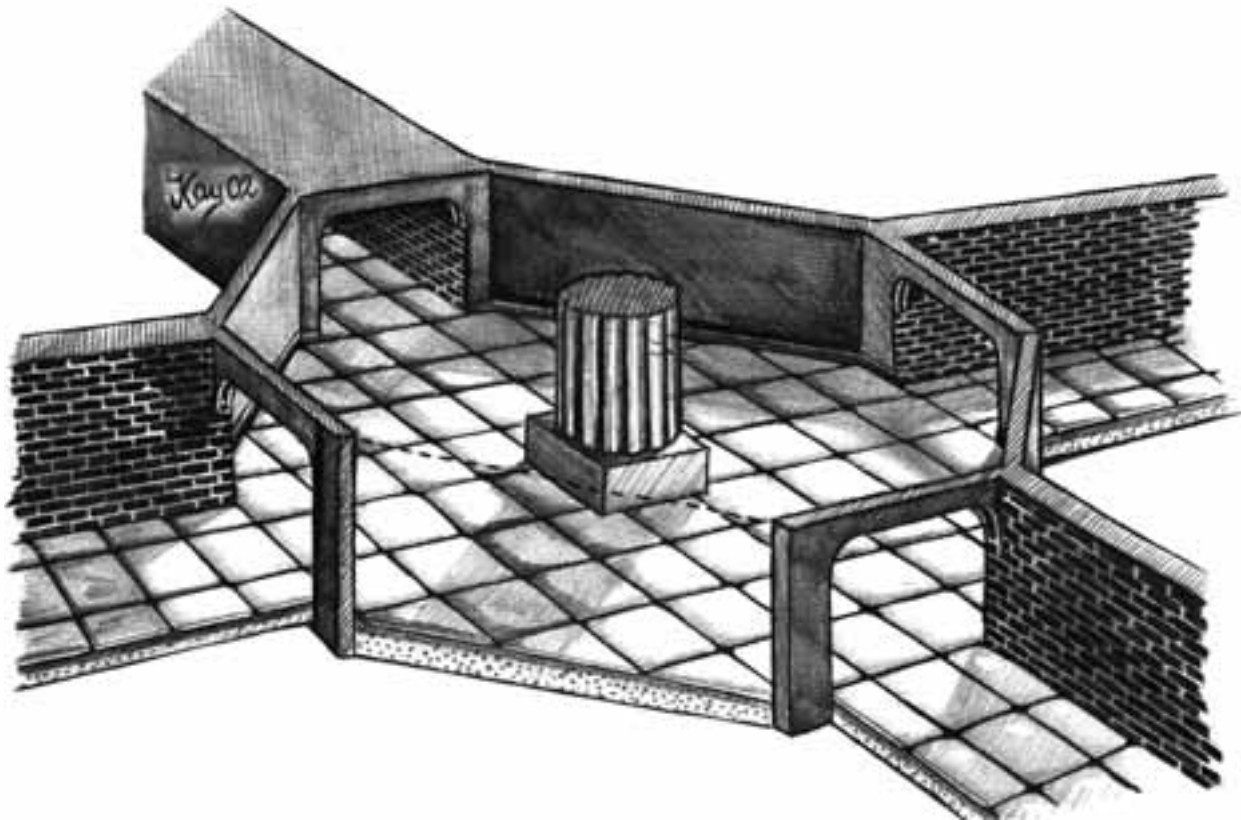

tions include the use of chemicals such as acid, contact poisons, and alchemist's fire. Any of these variations raise the CR of the trap by 1.

In terms of detection and disarming, a cautious rogue may notice the carefully hidden switch stones placed into the stone wall. Several things might tip off an observant climber to the trap that awaits her. The switch stones may be discolored, as if they had not suffered the same weathering as the rest, or perhaps they may stick out farther than those around them. The overhang along the top of the wall may serve as another sign of suspicion as the occasional drip of loose oil may fall on a character as she climbs. A few final signs of danger may be the faint odor of the oil that has stained the wall or the indication of discoloration caused by the cascading substances.

To disarm the trap, a rogue must either jam the trigger stones that line the wall or possibly reach the overhang and the wineskins that hold the oil. By carefully cutting the connecting mechanisms that activate the oilskins, a rogue may successfully disarm the trap. Either method requires a Disable Device check (DC 22), failure by 5 or more indicating that the trap is sprung as normal.

## WHICH WAY

**Trap Type:** Teleport Trap  
**Construction Type:** Magic  
**Activation Type:** Instant  
**Trigger:** Local; magic  
**Mechanism:** Magic  
**Effect:** Hindrance  
**Attack Bonus:** No attack roll necessary  
**Damage:** None  
**Save:** Will save (DC 14) negates  
**Search DC:** 30  
**Disable Device DC:** 30  
**Challenge Rating:** 4  
**Construction Time/Cost:** 5 days; 4,500 gp; 180 XP

Which Way is a magical trap designed to confuse those wandering about dungeons or castles. It is an octagonal room with four hallways leading into it. Every wall and passageway looks identical.

The trap has two stages. It is activated when anyone enters the room from any of the four passageways. At this time, there is no effect. Only when the intruders try to leave does the trap activate. As soon as an intruder leaves the room, a magically induced

darkness lasting for one round appears in the room and each hallway. Those within must make a Will save (DC 19) to avoid being *teleported* to a different hallway. All affected characters are transported to the same hall. If the DM wants to be particularly nasty, several of these traps can be placed in the same area of the adventure, so the PCs are never sure of which way they are headed. To leave the room in the direction intended requires a trigger word, which intelligent dungeon inhabitants in the area know.

Detecting the trap is extremely difficult (Search DC 30); it has more to do with sensing the trap's presence than actually seeing it. Disabling it is also difficult, since no obvious triggers can be found. To remove the trap, the stone around the archway must be chiseled off from both the walls and the ceiling at a depth of one-half inch. This must be done for each passageway through which the characters wish to travel, and each attempt requires at least 30 minutes of digging (likely attracting wandering monsters in the process).

## CHOKEHALL

**Trap Type:** Poison Gas Trap  
**Construction Type:** Complex mechanical  
**Activation Type:** Extended  
**Trigger:** Remote; switch  
**Mechanism:** Spring  
**Effect:** Injury, hindrance  
**Attack Bonus:** No attack roll necessary  
**Damage:** Poison  
**Save:** Fortitude save (DC 12) resists  
**Search DC:** 22  
**Disable Device DC:** 35  
**Challenge Rating:** 5  
**Construction Time/Cost:** 5 weeks; 5,000 gp

A sophisticated and difficult trap to beat, a Chokehall is designed to trap and possibly kill intruders between two lockable doors.

Entering the hall without unlocking both doors simultaneously triggers the initial phase of the trap. Thus, it normally takes two guards to allow safe passage through the hall, a very effective security measure. The initial phase of the trap involves a mechanism that bolts the unopened door shut. The open door shuts two rounds later, and it too is bolted. Both doors remain locked until keys are operated on the outside of both doors simultaneously. If this is done, the trap

is disarmed and it begins to reset immediately, ultimately unbolting the doors.

Once the doors both bolt shut, valves near the floor of the corridor open, filling the space with pooling breathtaker poison. The space fills one foot per round, until the eight-foot-tall ceiling is reached. The trap waits 10 minutes before pumping the gas back into the reservoirs. The doors then unbolt but remain locked.

A simple speakhorn allows guards on either side of the chokehall to communicate and coordinate their activities, though this also allows those using *gaseous form* or similar magic to bypass the hall.

There are several clues as to the nature of the trap. The first is revealed upon opening one of the external locks. In the process of opening it, the rogue may note a mechanism that has another purpose that is not immediately obvious. Another clue, once the rogue has the first door open, is the bolts in the floor and ceiling. The metal square ends of these are flush, but any rogue that detects them should certainly be suspicious. Additionally, the hall may have the remains of previous victims, depending on how often the area is cleaned. If the first door is wedged or kept open, the keyhole on the opposite side can be accessed. A successful examination (Search check DC 23) reveals it to have no actual function.

The speakhorn, the small vents along the walls, and the revelation that the doors are airtight should give a rogue all that he needs to figure out the nature of the trap. There is no trace of water or odors, which may actually give an alchemist an indication of the gas used.

Disabling the trap is rather easy, in one sense. The initial door can be wedged open, thus disarming the trap. However, opening the other door, now bolted, requires a successful Strength check (DC 35). Otherwise the characters must hack their way through it, which may be difficult depending on the material used. Additionally, carefully plugging all the vents disables the trap. This has the advantage that, once employed, the trap can cycle, allowing the party to simply use the far door as normal since it is now neither locked nor barred.

The reservoirs require basic maintenance, though judicious alchemy or magic can give

the mechanism a long life. The trigger and reset mechanism are powered by counterweights, which must be wound back up through physical or magical means. The trap also works well if a few undead are placed in the hall, providing a useful distraction for those trapped within the hall. While the party can try to keep the door open while fighting, they may forget to do so once proceeding. A DM should indicate early on that the door has a tendency to swing shut when left on its own.

## DEFENSE ARCANА

**Trap Type:** Dispel Magic Trap  
**Construction Type:** Magic  
**Activation Type:** Instant  
**Trigger:** Local; magic  
**Mechanism:** Magic  
**Effect:** Identification, hindrance  
**Attack Bonus:** No attack roll necessary  
**Damage:** None  
**Save:** None  
**Search DC:** 23  
**Disable Device DC:** 28  
**Challenge Rating:** 5  
**Construction Time/Cost:** 4 days; 3,500 gp; 140 XP

Flying spellcasters have long been the bane of any defensive position, be it a fort, castle, or series of barricades. Their ability to ignore even the craftiest of mundane defensive tactics makes them invaluable to any attacking army. The ability to go invisible makes them valuable as spies as well as weapons.

The Defense Arcana trap was devised as a way to detect and disable the magical protections of enemy spellcasters before they could cause much damage to defending troops and defensive structures. A series of gems is placed along the external walls of the fortification, as close to the top as possible. Then, a continuous *detect magic* effect is implanted within each gem. The effect can be targeted in any direction, though most often it is aimed straight up to detect flying attackers.

The second part of the trap is triggered when a magical aura of any strength is detected. The aura is then targeted with a *dispel magic* cast at 7th level. The aim of this is to drop any magical defenses and capabilities being used by the attacker, including *invisibility*, *fly*, and any others that may be active.

There are several variations of this trap, including one that hits the target with a *faerie fire* spell after detection. This allows the offender to be targeted by spells and attacks even if he is invisible. Sometimes protection spells such as *protection from chaos* or *minor globe of invulnerability* are triggered, especially where the trap has been placed near important fortifications such as towers or command posts.

This trap is quite difficult to detect, not because the gems are difficult to locate but because they are quite small relative to the areas in which they are imbedded. A rogue would have to climb the outer walls of the fortification in order to search the appropriate areas, an act likely to get him killed before he reaches his goal. Disabling the trap requires the rogue to chip away the stone surrounding each gem, as well as melting away the surrounding arcane runes with acid or a similar tool. If the runes are not melted away, the trap continues to function even without the presence of the gem.

The cost and construction time mentioned is for each gem used to defend the fortification. This can be quite costly for large structures such as castles, but they also benefit the most from such protections. The cost also includes the cost of the gem, which must be worth at least 100 gp.

## ELF MIRE

**Trap Type:** Outdoor Entrapment  
**Construction Type:** Magic  
**Activation Type:** Instant  
**Trigger:** Local; magic  
**Mechanism:** Magic  
**Effect:** Ensnarement  
**Attack Bonus:** No attack roll necessary  
**Damage:** None  
**Save:** Reflex save (DC 23) avoids  
**Search DC:** 30  
**Disable Device DC:** 30  
**Challenge Rating:** 5  
**Construction Time/Cost:** 1 week; 4,500 gp; 180 XP

This trap was first perfected by elves, hence the name. It has since been adopted by almost all of the woodland races, at least those who regularly produce druids. Centaurs, animen, and many fey communities use this trap or subtle variants thereof.

The trap is set across a large area where invaders, or any visitors who are not forewarned, are likely to travel. Likely targets include an easy grade up or down a hill, a path through dense forest, or a rocky ledge that could provide a good view of the land beneath. A skilled druid places magical triggers in the ground and the surrounding plants, which turns the entire area (usually at least 50 ft. by 50 ft.) into a trap. Whenever anyone enters the region without first speaking a safeword the trap is triggered, but the magic is not cast until one round later, long enough for an entire group to enter the affected area.

The first spell to be triggered is *transmute rock to mud*. The entire region encompassed by the spell becomes a mire, dragging down men and animals. Then, a round later, the second spell, *transmute mud to rock*, is triggered. The trapped invaders are now frozen in stone. If the area where the trap was set is still inhabited, someone eventually comes along to determine if those trapped are hostile or not. Friendly or neutral beings are freed; archers shoot down evil beings. Of course, if this trap is set by evil beings, anyone caught in it is likely dead.

A Reflex save (DC 23) can be made to avoid either spell effect; those who fail the first may still try to make the second.

Escaping from the stone requires dealing it 50 points of damage. The stone has a hardness of 8. Area effect attacks aimed at the stone also impact any beings trapped in the stone. Trapped beings suffer a -10 to any Reflex saves to avoid such attacks. Spells with somatic components may not be cast by trapped beings unless prepared with the Still Spell feat.

## GIANT'S STEP

**Trap Type:** Poison Gas  
**Construction Type:** Complex mechanical  
**Activation Type:** Instant  
**Trigger:** Local; pressure plate  
**Mechanism:** Gas, spring  
**Effect:** Injury  
**Attack Bonus:** No attack roll necessary  
**Damage:** Poison  
**Save:** Fortitude save (DC 21) to resist  
**Search DC:** 23  
**Disable Device DC:** 25  
**Challenge Rating:** 5  
**Construction Time/Cost:** 5 weeks; 5,000 gp

A number of traps, especially those built by smaller races, are designed so that light beings can scamper safely across them, while heavier beings trigger them. Small races can, thus, move freely through a maze of traps to which larger beings then fall victim. It takes a bit of engineering and ingenuity to devise a trap that a giant can safely traverse while letting smaller creatures suffer the effects.

This trap is one such example. The original design was probably commissioned by a green dragon, but it has since been adopted by many other dragon species, as well as the more clever species of giants (especially cloud giants, who tend to build large castle complexes).

The trap is often placed in a long corridor, which allows the gas to build up as trespassers make their way down. A pressure plate at the entry of the corridor, which even a light being can trigger, activates a pump that begins to pump a deadly toxin into the air. The gas is pumped through a series of tubes drilled through the massive stone blocks that form the floor of the corridor. These blocks, in turn, are mounted on thick, heavy springs, which require considerable weight (at least 1,000 lb.) to push down. In their normal resting position, the holes in the block are perfectly aligned with the tubes leading out from the gas pump. Gas flows into the blocks first and then into the corridor.

When a large being (a giant or a dragon) walks on the blocks, the springs compress, so that the tube pumping the gas is blocked. The springs decompress slowly, so that the giant has time to walk to the other end of the corridor and trigger a second plate, which resets the trap (this second plate also requires at least 1,000 lb. of pressure to depress). When a light being walks across the blocks, though, they do not compress, and thus, the gas is pumped.

The exact gas used is up to the DM. Good or neutral beings tend to use a crippling gas, causing initial and secondary damage of 2d6 temporary Dexterity. Evil beings generally use a more lethal poison, often one that causes 2d6 points of temporary Constitution on initial and secondary damage. The trap's CR as presented assumes use of non-lethal gas, so DMs may have to adjust the CR if using a more deadly poison.

Clues that might indicate the presence of this

## NEW CONDITION: LAME

Characters whose legs and feet are severely injured by traps or other dangers can become lame. This condition reduces their movement rate by three-quarters and their Dexterity by 6 points for all actions in which legs and feet are vital (including combat). Ranged combat, spell use, and other attacks that do not require movement are not penalized. In addition, the character is always considered flat-footed. If the character can fly, the penalty does not apply to melee and the character is not flat-footed. The character may not run or charge.

This condition lasts until the character is tended overnight by someone who makes a successful Heal check (DC 15) or the character is fully healed by magical or mundane means.

trap include the slight unevenness of the blocks that compose the corridor, the small-but-visible holes in their upper surface, or the initial trigger block. Disabling the trap will involve either getting 1,000 lb. of mass onto each block as the party moves, or, somewhat easier, sliding a block of some sort between the gas pump and the first block. A thin piece of metal or wood would do the trick. (Anyone who has *minor creation* could create such an item trivially.)

The lid of the box, flush with the floor, has four toothed rods extending downward. These are engaged with a series of gears. The gears lead to a spindle and rope. When pressure is applied to the lid, it begins to drop. The gears turn, stepping down the one-foot drop to a few turns of the spindle. Once the lid reaches the bottom of the box, the spindle is engaged with the jaws of the trap and disengaged from the lid. The torsion of the rope then drives the jaws together onto the target's leg.

## JAW BOX

**Trap Type:** Trapped Leg Trap  
**Construction Type:** Complex mechanical  
**Activation Type:** Instant  
**Trigger:** Local; switch  
**Mechanism:** Torsion, gear  
**Effect:** Ensnarement, hindrance, injury  
**Attack Bonus:** +15 grapple  
**Damage:** 2d6  
**Save:** Reflex save (DC 16) avoids  
**Search DC:** 25  
**Disable Device DC:** 21  
**Challenge Rating:** 5  
**Construction Time/Cost:** 5 weeks; 5,000 gp

There are a number of variations of the leg traps that were originally used for trapping animals. The Jaw Box has advantages over a number of other designs. First, since it was designed to be set underneath floor level, it uses the falling weight of the victim to wind the mechanism. This gives it longevity. Using torsion, it eliminates the need for elaborate and expensive springs. The design also allows the device to be relatively compact. Many other traps rely on counterweights, which require a rather large amount of space underneath the floor.

A character stepping on such a plate has some time to react, as the floor is felt to give way. The mechanism's use of the character's weight also means it slows down somewhat as the lid drops, giving even more time to react. If the Reflex save is successful, the trap has not completed its process. The lid slides back up to a normal position, and the mechanism is still set for activation.

Failing to evade the jaws results in 2d6 points of damage to the character's leg (the character is now considered lame, see sidebar). The character is also trapped within the jaws, requiring a successful Escape Artist check (DC 18) to break free. Failure by 5 or more on this roll results in an additional 1d6 points of damage to the character. Alternatively, a Strength check (DC 22) allows a character to pull the jaws apart long enough for a trapped character to escape. Trapped characters receive a -4 penalty on any such checks due to their poor leverage. After the character has been freed, the jaws come fully together and the gears reset. The jaws then immediately fall back to their original position. At this point the trap can be reset by pulling the lid back up into place.



The Jaw Box can be detected like other pressure plate traps, by the difference between it and the rest of the floor. Wear marks can also distinguish the section of floor that the area's denizens routinely avoid. Disarming the trap requires applying wedges to the lid.

Variations commonly use poison or barbed spikes for the jaws. The Jaw Box is also effective for outdoor use, given its relatively small size (approximately 18 inches on a side).

## LIGHT BURST

**Trap Type:** Flare Trap  
**Construction Type:** Complex mechanical  
**Activation Type:** Instant  
**Trigger:** Local; switch  
**Mechanism:** Pressure, gear  
**Effect:** Hindrance, identification  
**Attack Bonus:** No attack roll necessary  
**Damage:** None  
**Save:** Reflex save (DC 20) avoids  
**Search DC:** 25  
**Disable Device DC:** 28  
**Challenge Rating:** 5  
**Construction Time/Cost:** 5 weeks; 5,000 gp

One of the best ways to neutralize threats is not to attack them directly, but to hamper their ability to respond to your guards. A light burst is an excellent mechanical means for doing so.

A pressure plate activates the trap as well as an alarm that alerts guards to the presence of trespassers. A panel in the ceiling opens, releasing a spray of alchemically treated metal powder that is then ignited. The ignited powder creates a quick, intense burst of light. The flash may blind anyone not specifically turned away or with a covered face.

Characters within 30 ft. of the pressure plate must make a Reflex save (DC 20). A successful save means the character was able to turn away with closed eyes, or throw up an arm to block the light. Characters that make their saves are dazzled for 1d3 rounds by the bright light, but suffer no further ill effects. Those who do not make their saves are blinded for 1d3 minutes and dazzled for an additional 2d6 rounds thereafter. Characters with evasion are unaffected with a successful save, and those with improved evasion are merely dazzled even if they fail their save.

The pressure switch is the most likely hint of the presence of a trap, followed by the ceiling panel. Small traces of ash might be noticed, but unlike a fire attack, there is no great amount of heat produced. Scorch marks on the ceiling are faint at best. The presence of small amounts of fire byproducts warns of the trap's function.

Disarming the trap is a straightforward spiking of the pressure plate. An ambitious character can spike the ceiling panel as well, but it is not necessary to disable the mechanism.

A light burst works well for castles and other populated areas. It can also be combined with the release of undead or other guardians who can take advantage of the characters' temporary blindness. The mechanism is charged, lasting so long as powder remains in the reservoir. Motion of the pressure plate provides all the energy needed for the rest of the trap. Because of this, the other parts of the mechanism are fairly long lasting, requiring only a small amount of maintenance if used over a period of many years.

## MISDIRECTED MECHANISM

---

**Trap Type:** Fire Trap  
**Construction Type:** Magic  
**Activation Type:** Instant  
**Trigger:** Magic  
**Mechanism:** Magic  
**Effect:** Injury  
**Attack Bonus:** No attack roll necessary  
**Damage:** 2d6+9  
**Save:** None  
**Search DC:** 30  
**Disable Device DC:** 25 (see below)  
**Challenge Rating:** 5  
**Construction Time/Cost:** 1 week; 9,000 gp; 360 XP

This trap appears to be a featureless door, with no handles or hinges obvious in its construction. Sixteen metal levers, numbered 1–16 in four rows, cover the wall beside it. Each has three marked settings. The first and last rows are all in the up position, and the middle two rows are in the down position. Inscribed above the levers is the phrase *‘I and myself and myself make four, but nothing is five and six.’*

Anyone reaching for a lever takes 2d6+9 points of fire damage. If a lever is actually grasped, the character doing so takes a further 1d6 points of fire damage.

There is a permanent *wall of fire* with a permanent *invisibility* on it just in front of the levers. The heat side is aimed toward the levers on the wall. Anyone reaching for the levers must pass their arm through the fire. Furthermore, the levers are quite hot, causing additional damage if grasped.

The misdirection is that none of the levers actually do anything. They can be moved into various positions and will make a variety of clicking sounds. The phrase scrawled on the wall above them is meaningless.

The door has a *permanent image* placed upon it, hiding a recessed handle two feet to the right at a height of five feet. With a little bit of strength (Strength check DC 15), the door can be swung out into the room and passed through with no further trouble.

The wall and the door both detect as magical. Hitting the area with a *dispel magic* might dispel any or all of the effects present. The DC for such a check is 23.

A Disable Device check (DC 25), if successful, confirms the boundaries of the *wall of fire*, and that there is no triggering mechanism. It is a stationary, fixed effect and not a mechanism. This is a clue to what is going on.

This trap works well in protected interiors of organizations, like mage guilds. It is relatively expensive, but it is long lasting and has proven to be a useful method of keeping out even fairly strong groups. The Misdirected Mechanism works best if placed after a variety of lever-activated mechanisms, some trapped but most not. It is also suggested that traps with phrases be established as a test to be allowed to enter, either religious or intellectual. In this case, the test measures the party’s lateral thinking capability.

## MOGRO’S COOP

---

**Trap Type:** Monster Trap  
**Construction Type:** Complex mechanical, magic  
**Activation Type:** Extended  
**Trigger:** Local; switch, magic  
**Mechanism:** Gear, magic  
**Effect:** Ensnarement, injury  
**Attack Bonus:** No attack roll necessary  
**Damage:** 1d6  
**Save:** Reflex save (DC 15) avoids  
**Search DC:** 24  
**Disable Device DC:** 28  
**Challenge Rating:** 5  
**Construction Time/Cost:** 1 week; 1,000 gp; 10 XP.

Mogro’s Coop is an insane yet deadly trap created by the arch priest Mogro. Originally discovered deep within the dungeon levels below his temple, this trap combines a complex fencing system, a series of *hold person* spells, and a small flock of cockatrices (MM 38) to punish nosy trespassers. It is well known that the arch priest valued his privacy and this trap is but one small example of the lengths to which his insane (yet brilliant) mind would go to protect his valued privacy.

Until recently, this trap could only be found (or rather, triggered) within the dungeon levels below Mogro’s temple lair. However, in recent years this trap has appeared in dungeon complexes, within the towers of powerful mages, and even in the vaults of some eccentric nobles.



Mogro's Coop is generally placed within a large stone passageway (at least 10 feet wide) or within a chamber measuring no less than 20 feet wide. This passageway or chamber almost always carries a pungent odor from the nearby cockatrices. There are four holes in the area, typically one in each wall of the chamber. These holes are just big enough to allow the cockatrices free movement. The holes are each covered by a small iron fence. A successful Listen check (DC 15) allows a character to hear the sounds of the cockatrices gobbling from one or more of these holes.

This trap is activated when a character breaks a thin tripwire that stretches across the chamber floor. Breaking this wire activates a series of complex gears hidden within the chamber walls. These gears quickly raise several iron fences from within the chamber floor, connecting them to locking mechanisms hidden within the ceiling of the chamber. Runes cover each of the fences. These fences divide the chamber into four equal sections, trapping each character within one of the areas. If a character is standing on an area where the fencing is raising, a successful Reflex save (DC 15) is required to avoid taking 1d6 points of damage.

Two secondary gear effects take place after the fences are raised. First, any doorways in the chamber close and lock. A successful Strength check (DC 20) is required to prevent any open doorway from closing. A successful Open Lock check (DC 20) unlocks the chamber door. Also, the small iron fences covering the holes in the walls raise, allowing one cockatrice to enter each section.

As mentioned above, the fencing itself is covered with runes and magical inscriptions. If a character touches any part of a fence she must make a successful Will save (DC 16) or be stricken with a *hold person* spell with a duration of five rounds. Each section of fence contains only one charge.

A rogue with an eye for detail may notice a few signs of foul play leading to the discovery of this trap. One such sign may be the discovery of the thin tripwire that extends across the chamber floor. Among the more obvious signs are the noises made by the cockatrices and the small fenced holes in the walls.

There are several ways to disarm or avoid

this trap. The first option a rogue may have is to simply avoid the tripwire in the passage floor that activates the trap. Other options for disarming this trap are jamming the fence mechanism that rises from the floor with at least four daggers or climbing spikes.

## MUD COLLAPSE

---

**Trap Type:** Collapsing Ceiling  
**Construction Type:** Magic  
**Activation Type:** Instant  
**Trigger:** Local; magic  
**Mechanism:** Gravity, magic  
**Effect:** Ensnarement, injury  
**Attack Bonus:** No attack roll necessary  
**Damage:** 8d6  
**Save:** Reflex save (DC 15) avoids  
**Search DC:** 30  
**Disable Device DC:** 30  
**Challenge Rating:** 5  
**Construction Time/Cost:** 5 days; 250 gp; 10 XP

This is a simple, one use magic trap. A rough corridor leads to an archway, perhaps before the central room in a crypt. The magical trigger is placed on the inside of the arch, activating if anyone that is not undead passes through it.

The effect is simply a *transmute rock to mud* aimed at the ceiling. This causes the ceiling to collapse, dealing 8d6 points of damage to everyone in the corridor. The collapse affects the alcove beyond the archway, out 20 feet, and back another 30 feet, with slide zones extending out another 10 feet in each direction. See the core rules (DMG 114) for more information on cave-ins.

This is a relatively simple trap to set up, but the degree of structural damage incurred leaves something to be desired. It is best within a larger complex, where casual annoyances have already been weeded out, and the mud collapse can thus serve as a last ditch protection.

## ONE RUG, SLIGHTLY USED

---

**Trap Type:** Constriction Trap  
**Construction Type:** Magic  
**Activation Type:** Instant  
**Trigger:** Local; magic  
**Mechanism:** Magic  
**Effect:** Injury, hindrance  
**Attack Bonus:** +10 melee

**Damage:** 1d10 per round  
**Save:** Reflex save (DC 20) avoids rug  
**Search DC:** 30  
**Disable Device DC:** 30  
**Challenge Rating:** 5  
**Construction Time/Cost:** 3 days; 2,500 gp; 100 XP

A magical booby trap that was bested years before by a clever rogue, this particular *rug of smothering* lies primed but impotent beneath a toppled bookcase. The rug had originally been placed in front of the upright bookcase by its owner in order to protect his valuable books from pilferers, but when he passed away and his valuable stronghold fell into disrepair, treasure seekers invaded his home seeking their fortune. A particularly wily rogue figured out that the rug would leap up and entrap anyone who stood before the bookcase without knowing the password. She decided that discretion was the better part of valor, tipped the heavy bookcase onto the rug, and bypassed the contents of the shelves in favor of the contents of the rest of the room. The rug has lain here ever since, patiently waiting for someone to lift the bookcase and trigger the trap.

Because of the bookcase lying on top of the rug, this is not an obvious trap. Studying the room, it is apparent that someone has ransacked it looking for valuables. The only remaining items of apparent value are a few books scattered beneath a heavy wooden bookcase. Lifting this massive antique requires a combined Strength of 30, and the individuals lifting the bookcase must be standing in front of it in order to raise it to a standing position. As a consequence, they find themselves standing on the 10 ft. by 20 ft. rug when it is triggered.

The rug proceeds to enfold them in a constricting, smothering mass of magical carpeting. It deals 1d10 points of constriction damage per round. Armor worn provides damage reduction against this damage equal to its armor check penalty. So, a trapped character in full plate mail would have damage reduction 6/- for purposes of the constriction damage.

Detecting this trap is difficult—it is not obvious at first unless a *detect magic* spell is cast. Even then, it will only reveal that the rug is magic, not necessarily that it is a *rug of smothering*. A successful Spellcraft check (DC 25) identifies the rug for what it is. The *rug of*

*smothering* has an AC of 15 and 30 hp. It is immune to blunt weapon damage, and any attacks that deal more than 10 points of damage also damage those trapped in the rug. Half of any damage beyond the first 10 points in a single hit is dealt to the person trapped within the rug. So, if a trapped character's friend hit the rug for 18 points of damage with a sword strike, the character within would take 4 points of damage and the rug would take 14.

The rug can smother only one creature at a time.

## PULLING THE PIN

**Trap Type:** Sliding Rock Trap  
**Construction Type:** Complex mechanical  
**Activation Type:** Instant  
**Trigger:** Local; switch  
**Mechanism:** Pressure, gear  
**Effect:** Hindrance, ensnarement  
**Attack Bonus:** No attack roll necessary  
**Damage:** None  
**Save:** None  
**Search DC:** 26  
**Disable Device DC:** 30  
**Challenge Rating:** 5  
**Construction Time/Cost:** 6 weeks; 6,000 gp

This trap is best placed in multi-level dungeons or very large castle complexes since it requires at least two floors and a huge mechanism to operate.

The core of the trap is a vertical shaft carved into an even larger block of stone that intersects one corridor and ends just at the ceiling of a second corridor, one that lies directly below the first. This creates a wall in the upper corridor, and a hole in the ceiling of the lower passage. Passage beyond the wall requires the trap to be triggered, lowering the shaft and stone block so that the upper corridor is now unblocked. This of course blocks the lower passage and possibly traps an unwary character.

When encountered in the upper passageway, the shaft appears to be a stone wall that blocks passage. A Search check (DC 15) reveals abrasions and cracks that indicate the wall moves somehow, but such examination does not offer any clues as to how (dwarves gain an automatic Search check to notice this if they come within 10 feet of the wall). Characters can attempt to break through the two feet of

stone (hardness 8, hp 360) but doing so reveals only the dark shaft and more stone on the other side (also 2 feet thick). The shaft goes up nearly 10 feet before ending in solid rock, and it descends as far as the next level of the dungeon. If a character were to climb down and jump out into the lower passageway, he would trigger the shaft to drop as normal.

When traveling through the lower passageway, a Spot check (DC 15) allows a character to Spot the shadowy shaft on the ceiling of the passageway before he steps underneath it. A rogue actively searching for traps might notice the shaft or detect the pressure plate on the floor beneath it (Search check DC 15). Either way, it is not immediately obvious that the two are linked. At the DMs discretion, a soft or breakable covering might be placed over the shaft entrance in order to hide it from casual view (the Spot DC increases to 25). As soon as a character steps onto the pressure plate beneath the shaft, the trap is sprung. Allow the character a Reflex save (DC 18) to jump out of the way of the shaft as it drops into place. Failure means no damage, but the character is trapped in a prison whose walls are two feet of solid stone. The only means of escape is straight up the shaft (Climb check DC 15), which could have its own problems, as shown below. The exact height of the shaft is left to the DM, but at least 50 feet is recommended.

The contents of the shaft are also left up to the DM. One possibility is a stone block that is positioned within the shaft to fall when jarred by the trap's operation. This stone deals 4d6 points of damage to any trapped character and pins them under a 300 lb. stone. Add 1 to the CR of the trap if this option is used. Creatures that would attempt to kill any trapped character could also populate the shaft; such beings almost always try to finish off any trapped characters before attacking foes that approached from above. Chokers, cloaklers, darkmantles, and monstrous spiders all make excellent choices depending on the capabilities of the characters involved and the surroundings in which the trap is located. Such monsters are not included in the CR of the trap, so experience awards should be adjusted accordingly.

Once the trap has been activated, the lower passageway becomes inaccessible except by breaking through the shaft or resetting the mechanism. This can be accomplished by

finding the mechanism's control room and rotating the winch that raises the shaft. It requires a Strength check (DC 20) to start the mechanism moving, after which its gears and pulleys make finishing the job significantly easier.

Disabling the trap can be accomplished by either spiking the pressure plate at the bottom, or by sabotaging the winch mechanism in the control room. The latter requires a Disable Device check (DC 26) and locks the shaft in its current position permanently. Spells such as *soften earth and stone* or *stone shape* on the bottom of the shaft while it is down cause it to collapse, effectively shortening the shaft by 10 feet but not destroying the mechanism. In this way it is possible to slowly destroy enough of the shaft to cause the trap to be ineffective. Shortening the shaft in this manner combined with sabotaging the mechanism could lock the shaft in a neutral position that would block neither the top nor the bottom corridor.

## THE OPEN GRAVE

**Trap Type:** Burying Dirt Trap  
**Construction Type:** Simple mechanical  
**Activation Type:** Extended  
**Trigger:** Local; switch  
**Mechanism:** Spring  
**Effect:** Ensnarement, injury  
**Attack Bonus:** No attack roll necessary  
**Damage:** 4d6  
**Save:** Reflex save (DC 20) partial  
**Search DC:** 22  
**Disable Device DC:** 22  
**Challenge Rating:** 5  
**Construction Time/Cost:** 5 weeks; 5,000 gp.

The Open Grave is a simple trap used by groundkeepers and gravediggers to punish would be grave robbers. By using an enticing coffin and a landslide of poisoned soil, this trap is not only designed to kill grave robbers, but to fill their own graves as well.

This trap is typically found within the grounds of a large cemetery that suffers from regular raids by grave robbers. In some cases, this trap may be found within underground burial sites as well, as it protects holy or family burial plots from theft and vandalism.

The first step of this trap lies within the open grave itself. At the bottom of a 10-ft.-deep

grave lies an ornate coffin, inlaid with gold and jewels. This richly decorated coffin is actually a large percentage of this trap's construction cost, as the coffin is typically valued at no less than 2,500 gp. A successful Appraise check (DC 15) reveals the coffin's worth, effectively drawing in potential thieves. Next to the grave is a large pile of soil (enough soil to fill the open grave if necessary). The soil is laced with carrion crawler brain juice poison (DMG 80). If touched, a successful Fortitude save (DC 13) is necessary or the victim is paralyzed.

The abnormal depth of the grave is intentional, as it increases the difficulty to escape from the pit and ensures that trapped creatures are properly buried. If a character jumps or climbs down onto the coffin, or attempts to move it in any way, a highly sensitive spring mechanism is activated. The mechanism triggers the spring-loaded platform at the top of the grave, dumping the pile of dirt onto the character within. She must make a successful Reflex save (DC 22) or suffer 2d6 points of damage and be considered pinned. The pinned character suffers 1d6 points of subdual damage per minute while pinned. If she falls unconscious, she must make a successful Constitution check (DC 15) or take 1d6 points of normal damage each minute until she is either freed or dead.

Once pinned by the soil, the victim must make a successful Fortitude save (DC 13) or suffer from the effects of the carrion crawler brain juice poison that laces the soil. She must make this saving throw for each round she spends pinned beneath the soil. There is enough poison within the soil to affect a trapped character for three minutes, after which time the character need not make any further saves.

Additionally, a successful Escape Artist check (DC 22) allows a pinned character to move two feet closer to the surface. A successful Strength check (DC 22) has the same result.

A rogue with an eye for detail may notice the added depth of the grave, which could cause her to be wary. She might also detect the faint odor of the poison-laced soil. A final sign may be a slight exposure of the trapdoor used to launch the soil into the grave. The groundskeepers perform regular maintenance on the trap, including making sure the door is hidden and the coffin clean.

To disarm this trap, a rogue need only avoid triggering the coffin release switch or jam the trapdoor under the soil with a Disable Device check (DC 22). Of course on a failure of 5 or more the trap is triggered from the surface and proceeds as normal.

## THE SINISTER STAIRS

**Trap Type:** Mechanical Stair Trap  
**Construction Type:** Complex mechanical  
**Activation Type:** Extended  
**Trigger:** Local; switch  
**Mechanism:** Gravity, gear  
**Effect:** Injury  
**Attack Bonus:** No attack roll necessary  
**Damage:** 6d6 (3d6 for each cylinder)  
**Save:** Reflex save (DC 22) avoids  
**Search DC:** 22  
**Disable Device DC:** 22  
**Challenge Rating:** 5  
**Construction Time/Cost:** 5 weeks; 5,000 gp

The Sinister Stairs is an insidious trap that utilizes the power of gravity and combines it with simple mechanics to release large, metal-spiked cylinders. The origin of the trap design is a bit of a mystery, but many scholars place the origins near (or possibly within) the ruins of the archpriest Mogro's temple. This is merely speculation, but these rumors make this trap no more or less effective as a deterrent to thieves, trespassers, or overly curious adventurers.

The placement of this trap is something that must be considered beforehand by the creator, as the architecture involved is somewhat confining. The necessity of the dual-staircases can create a problem in the location of this trap. With that said, this trap may be found in specific locations within strongholds, castles, or elaborate dungeon complexes. In some cases, creators place a false door at the top of the second staircase to draw the curious in closer. Also, a second trap may be placed on the false door to further punish persistent trespassers.

This trap is activated by two methods, either when a character steps onto the trigger plate hidden in the floor at the bottom of one staircase, or by triggering the second plate hidden in the second staircase itself. Once triggered, a series of gears releases a trapdoor concealed in the ceiling over the staircase that swings open. With the trapdoor open, a large metal cylinder covered with metallic

spikes falls onto the staircase and rolls down towards the character that activated the trigger. A successful Reflex save (DC 22) allows a character to avoid the cylinder. A character struck by the cylinder suffers 3d6 points of damage and must make a Strength check (DC 15) to avoid being pulled under the cylinder, suffering an additional 3d6 points of damage.

Ideally, characters should run away from the cylinder by moving towards the second staircase. If not careful, characters may trigger the second falling cylinder, thus necessitating a second set of saving throws and Strength checks for all in the cylinder's path.

A rogue with an eye for detail may notice the contours of the carefully hidden trapdoors inset into the stairway ceiling. Also, she may notice the slight raise of the trigger-plate within the staircase or along the passage floor.

To disarm the trap, a rogue must either jam the trigger plates on the floor and stairs or jam the trapdoors in the ceiling with a large object.

## THE SPINNING TUNNEL

**Trap Type:** Acid Trap

**Construction Type:** Complex mechanical

**Activation Type:** Extended

**Trigger:** Local; pressure plate

**Mechanism:** Gears

**Effect:** Injury

**Attack Bonus:** No attack roll necessary

**Damage:** 5d6

**Save:** Fortitude save (DC 25) halves

**Search DC:** 25

**Disable Device DC:** 25

**Challenge Rating:** 5

**Construction Time/Cost:** 5 weeks; 6,000 gp

The Spinning Tunnel trap catches dungeon crawlers by surprise with a rotating tunnel that dumps a vat of acid on them. The trigger is a pressure plate under a stone tile that sets the complex collection of gears in motion. The gears turn a 20-ft. section of the tunnel 90 degrees clockwise. Chains on the left wall, which becomes the ceiling as the tunnel turns, are designed to be grabbed for balance and support. However, the chains are attached to stone

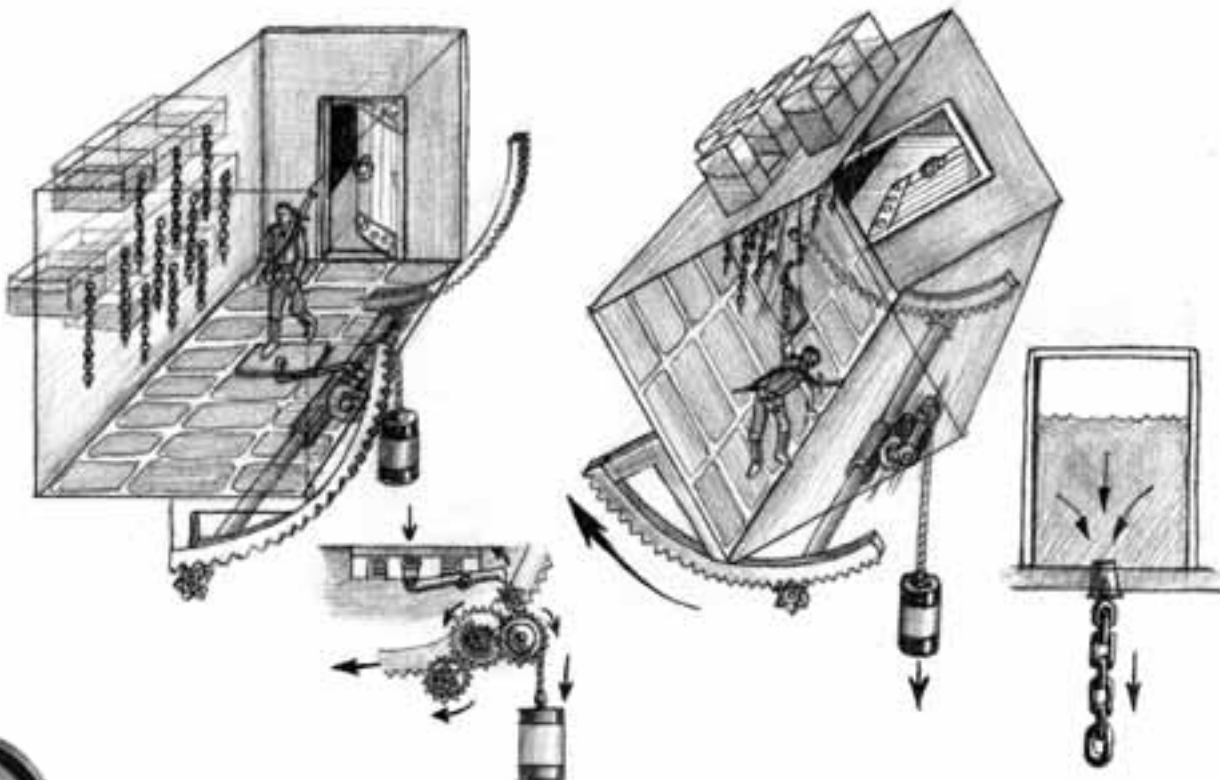

plugs that pop open and pour acid from a vat hidden behind the blocks on the left wall. As the tunnel turns and the chains are pulled, acid pours on the victims.

The floors and walls of the tunnel must be stone-tiled. Anything else would melt under the acid. Twelve chains hang from stone hooks on the left wall. When a victim steps on the trapped tile, the whole passage begins to shake and turn. All those within 10 feet of the victim must make a Balance check (DC 15) to see if they can maintain their footing without grabbing the chains. Failure means that the victim has grabbed a chain out of reflex and opened a hole for the acid issue forth.

The stream of acid pours for four rounds and the victim takes 5d6 points of damage for each round spent under the flow. An additional Reflex save (DC 25) halves the damage. After the first round, another character can pull the victim to safety with a Reflex save (DC 16). If the rescuer fails the save, he takes 3d6 points of acid damage but still pulls the victim to safety. A victim of acid suffers 1d6 points of damage for three rounds after getting away from the acid stream. All equipment carried by a victim has a good chance of melting under the acid stream, requiring a Fortitude save (DC 16) to avoid being destroyed. The DM should determine what equipment was exposed and what survived.

## WALTZING BLADES

**Trap Type:** Blade-Loaded Pillar Trap  
**Construction Type:** Complex mechanical  
**Activation Type:** Instant  
**Trigger:** Remote; switch  
**Mechanism:** Gear  
**Effect:** Ensnarement, injury  
**Attack Bonus:** +10 melee  
**Damage:** 1d6 per blade  
**Save:** None  
**Search DC:** 22  
**Disable Device DC:** 24  
**Challenge Rating:** 5  
**Construction Time/Cost:** 5 weeks; 5,000 gp

Waltzing Blades is a manually operated trap that uses a series of complex gears and mechanisms to rotate several large, blade-covered pillars around a grand hall. Whether it be for protection, security, or punishment, this trap is effective without being overly expensive.

Due to the complexities of constructing and designing this trap, it has limited use in tight quarters or in areas with little or no manual support. Large dungeon complexes, castles, and strongholds are among the most common, with subterranean caverns being more rare as the pillars must be disguised as natural stone rather than support pillars.

At a casual glance, this trap appears as a large hall or chamber filled with ornate carvings along the walls, floor, and ceiling. Inside the room are seven large stone pillars that appear to reinforce the hall's high ceiling.

A guard who is stationed within the hollow stone pillar that sits at the far side of the hall activates the trap. The guard, upon seeing intruders through the pillar's eyeholes, can activate the remaining six gear-driven pillars. Once activated, all doorways in the hall close and lock. A successful Strength check (DC 20) allows a character to hold a closing doorway open. A successful Open Lock check (DC 20) allows a rogue to open the door's lock. Some builders have been known to place secondary traps onto the additional door within the hall, as characters may scramble to escape once the pillars are set into motion.

Next, two large blades extend from each of the six remaining pillars and begin to spin and rotate in a set pattern around the room. A series of complex gears attached to the top of each pillar allows each pillar to follow a track that is concealed by the engravings in the ceiling of the hall. A successful Search check (DC 22) allows a rogue to notice the small, engraved tracks.

Once the pillars are in motion they each follow a set track until they are either stopped by force or by the deactivation of the control switch within the guard pillar. Each blade has a +10 melee attack bonus and a speed of 10 feet per round.

An observant rogue with an eye for details may notice the above mentioned ceiling tracks or spot the glint of metal concealed within the six pillars. To disarm the trap, a rogue would need to either ruin the gears in the guard-pillar or damage the gears within each pillar individually.

## CHAPTER TWO

NEW TRAPS:  
CR 6+

## INTRODUCTION

This chapter presents full descriptions, game statistics, and illustrations of a variety of magical and mechanical traps. The trap names and statistics, as well as rules and mechanics derived from the d20 SRD are designated as **Open Game Content**. Background text and trap descriptions are designated as closed content.

## BLIND MAN'S BLUFF

**Trap Type:** Pit and Blindness Trap  
**Construction Type:** Complex mechanical, magic  
**Activation Type:** Extended  
**Trigger:** Local; magic  
**Mechanism:** Magic, gear  
**Effect:** Ensnarement, injury  
**Attack Bonus:** No attack roll necessary  
**Damage:** 6d6  
**Save:** Fortitude save (DC 15) negates  
**Search DC:** 27  
**Disable Device DC:** 27  
**Challenge Rating:** 6  
**Construction Time/Cost:** 4 weeks; 4,150 gp; 6 XP

Blind Man's Bluff is a complex pit trap that is accented with a *blindness* spell. The use

of this spell adds to the trap's effectiveness and increases the difficulty for a trapped character who attempts to escape. This trap is used primarily to injure and detain curious trespassers.

The trap itself is typically found within large dungeon complexes and strongholds, as the size of the pit itself and the gearworks used to control the moving wall requires a great amount of space to construct. It appears as a 10-ft.-square room with only one visible door. A piece of unique art or an ornate carving of the creator's choosing is typically mounted on the room's far wall. This is referred to as the trigger item. A popular variation uses valuable gems or precious metals to lure the greedy. A successful Appraise check (DC 15) allows a character to discern the value of the gems or precious metals in question.

The Blind Man's Bluff is activated when a character moves within 5 feet of the trigger item. When she does so, a *blindness* spell is triggered. A successful Fortitude save (DC 15) is required to avoid the spell's effect. The spell always targets the character closest to the trigger item. If two characters are equally close, determine the target randomly.

A character that fails her save is stricken blind and thus suffers from the spell's listed effects.

In many cases, a rogue will be the first into a room, thus increasing the trap's deadly effects if a group's only rogue is stricken blind. Once the spell is activated, a series of gears are set into motion that perform several functions.

The first is the release of a mechanism that closes and locks the room's only door. A successful Strength check (DC 20) is required to hold the door open. If the door is allowed to close, a successful Open Lock check (DC 22) is required to open the locked door.

Next, a series of gears begins to move the doorway wall toward the trigger item, thus moving characters closer to the trap's next step. The wall takes only one full round to reach the edge of the trapdoor described in the next step. A character that attempts to stop the movement of the wall must make an opposed Strength check versus the trap's gear mechanism. The gears have an effective Strength of 30.

Finally, a 5-ft. by 10-ft. trapdoor is opened in the floor, under the trigger item. This reveals a 60-ft.-deep pit trap. The pit is constructed from stone and is clean, containing no oil, spikes, or grinder blades. A character that falls into the pit takes 6d6 points of damage. Popular variations for this trap include the use of spikes or ooze creatures to further punish trapped characters.

Once inside the pit, a character must make a successful Climb check (DC 20) to scale the smooth stone surface.

With the trap activating by way of a magical trigger, it is considerably more difficult to detect than a conventional trap. The construction quality of this trap also adds to the difficulty of its detection as the walls and gears are virtually undetectable. A skilled rogue may notice a few subtle signs when detecting this trap. The first is possibly the faint smell of the oil used to keep the gears lubricated. The second sign may be a faint groove in the floor just at the edge of the trapdoor under the trigger item.

To disarm this trap, a rogue must either disarm the gears that close the chamber door or possibly disarm the release valve that is hidden near the top of the moving wall, just above the doorway. Again, popular variations are the addition of lock traps and other such traps designed to foil a rogue's disarming attempts.







## BURNING BREATH

**Trap Type:** Spouting Flame Trap  
**Construction Type:** Complex mechanical  
**Activation Type:** Instant  
**Trigger:** Local; switch  
**Mechanism:** Pressure  
**Effect:** Injury  
**Attack Bonus:** No attack roll necessary  
**Damage:** 6d6 plus burning  
**Save:** Reflex save (DC 24) avoids  
**Search DC:** 26  
**Disable Device DC:** 24  
**Challenge Rating:** 6  
**Construction Time/Cost:** 6 weeks; 6,000 gp

Followers of the god of the dead devised the Burning Breath trap and implemented it in a statue depicting the guardian of hell. The original guarded a grand temple to the deity, but the trap has since been adapted by many trapmakers for use in a variety of situations. While especially beloved of those who follow multi-faced deities, the basic mechanism works even for gods with only a single head, though some overly prideful deities might take offense at their icons spewing flames from their ears.

The appearance of the Burning Breath is straightforward enough; a statue, usually Large or Huge in size, of a deity stares down balefully at supplicants, while treasure, jewels, or sacred relics are piled at the altar in front of him. Should the treasure be disturbed, however, the trap is sprung. Specifically, a pump mechanism in the statue begins to spew burning liquid chemicals through the mouths of any heads or faces the statue may possess. In the case of multi-headed or multi-faced deities, each head or face is positioned so as to spray the widest possible area. In the case of single headed deities, the designers either rig the burning spray to come out of other orifices, such as ears, or, somewhat more respectfully, design the head to pivot, spraying blazing doom in a wide arc.

A successful Reflex save (DC 24) avoids the spray. Any creature within 20 feet of the statue must make this save, although anyone within 5 ft. of the statue gains a +2 circumstance bonus on her saving throw due to the nature of the trap's design.

The burning goop hurled by the statue is difficult to remove. If a victim does nothing but try

to doff their clothes or armor and wipe off the goop, they take 1d6 points of damage per round for two more rounds. If a victim does anything else (casts spells, moves, etc.), they take 3d6 points of damage on the first round following the attack, 2d6 on the second round, and 1d6 on the third before the goop burns itself out. A person can scrape the goop off another person as a standard action.

Detecting the trap is not simple. The trigger mechanism is hidden under the bait, and the fire-spewing orifices are high up and not easily inspected. Some possible clues include a faint line around the base of the altar, or the fact the mouth of the statue seem to be lined with hard metal and extend back much further than they should. Burned splotches on the floor or discolored patches on the statue where burning liquid splashed are other possibilities. The area around the statue will tend to be clear of furniture, scrolls, or other flammable objects for obvious reasons.

## FIRE SHOWER

**Trap Type:** Fire Trap  
**Construction Type:** Complex mechanical  
**Activation Type:** Instant  
**Trigger:** Local; switch  
**Mechanism:** Pressure, gear  
**Effect:** Injury  
**Attack Bonus:** No attack roll necessary  
**Damage:** 4d6 plus fire  
**Save:** Reflex save (DC 15) avoids  
**Search DC:** 22  
**Disable Device DC:** 28  
**Challenge Rating:** 6  
**Construction Time/Cost:** 6 weeks; 6,000 gp

A particularly nasty trap designed with groups of trespassers in mind, the Fire Shower consists of five pressure plates lined up in a row, each 10 ft. by 10 ft. Above every plate is a recessed, hidden nozzle.

The central panel is the main trigger, making the trap equally deadly to trespassers approaching from either side. When it is pressed, a nozzle in the ceiling fires a spray of burning oil. If any of the other plates are pressed when the trap is triggered, the nozzles over them also spray burning oil.

Once a character triggers the trap by stepping on the central plate, anyone within 5 feet of a

plate must make a Reflex save (DC 15) to avoid being sprayed with burning oil from the nozzles on the ceiling above them. Anyone failing the save takes 4d6 points of fire damage and is automatically considered on fire, taking 1d6 points of damage per round until the fire is put out. For complete rules for being on fire, consult the core rules (DMG 86).

The effects of being on fire do not stack, but damage from being on fire and damage from being hit by a continuing fire shower do. That is, a character in a fire shower takes 5d6 points of damage per round until out of the fire, and then takes only 1d6 points per round for being on fire if the character fails to put the fire out in subsequent rounds.

The trap is somewhat obvious, at least to experienced adventurers. The nozzles are hard to disguise, as are the multiple pressure plates. Signs of scorching and oil are also hard to remove, giving clues as to the nature of the trap. Disarming the trap is a little tricky, as each plate must be spiked. It is not immediately obvious why there are five pressure plates, and a thief may assume that there are simply five mechanisms in a row to make running across the area difficult. The fact that most of the plates do not move may confuse observers (at least until they try the middle one), causing them to carelessly trigger the trap.

A fancy trap requiring good maintenance and a source of oil, the Fire Shower requires the presence of a minimal staff to keep in working order. Other versions use acid, usually dealing 2d6 points of damage plus 1d6 points of damage per round for 1d3 rounds thereafter.

## FRODERICK'S ENSNARING FLOOR

**Trap Type:** Transformation Trap  
**Construction Type:** Magic  
**Activation Type:** Extended  
**Trigger:** Local; switch  
**Mechanism:** Spring, magic  
**Effect:** Ensnarement  
**Attack Bonus:** No attack roll necessary  
**Damage:** None  
**Save:** Reflex save (DC 21) avoids  
**Search DC:** 25  
**Disable Device DC:** 30  
**Challenge Rating:** 6  
**Construction Time/Cost:** 2 days; 1,800 gp; 72 XP

Froderick the Uncanny, archmage and puzzle-master, had an inordinate love of constructing magical nuisance traps. This one, which can be placed in any room or corridor with a stone floor, is a simple but effective means to hinder trespassers. A section of the floor likely to be stepped on is actually a hidden pressure plate. When depressed, the plate breaks a magical seal underneath the floor and activates the trap.

The first effect is a *stone to flesh* spell that affects the person who stepped on the trigger. Unless the character succeeds at a Fortitude save (DC 19), he and his possessions are instantly transformed into stone.

One round later, the affected character is targeted by a modified *meld into stone* spell that causes him to sink into the ground. If the character made his initial Fortitude save, this spell automatically fails. If not, he immediately sinks into the floor where he remains for 110 minutes.

Since the trap relies on a mechanical trigger, it is easy to find in comparison with most magical traps. Still, the pressure plate is cleverly built and fits the pattern of the floor quite well. Since the pressure plate is also very sensitive, jamming it in place requires a great deal of finesse. Even slight pressure could be sufficient to break the magical seal. A rogue who fails his Disable Device check by more than 5 may trip the trap.

This trap is often made more deadly by the inclusion of guardian monsters or even *summon monster* spells that trigger after the *meld into stone*.

## GIANT SUCKING SOUND

**Trap Type:** Vacuum and Blades  
**Construction Type:** Complex mechanical  
**Activation Type:** Instant  
**Trigger:** Local; pressure plate  
**Mechanism:** Vacuum, spring  
**Effect:** Movement, injury  
**Attack Bonus:** +14 melee  
**Damage:** 6d6  
**Save:** None  
**Search DC:** 24  
**Disable Device DC:** 24  
**Challenge Rating:** 6  
**Construction Time/Cost:** 6 weeks; 6,000 gp

Gnomes are merry pranksters whose cun-

ning may embarrass, but very rarely kills. While gnomes who dwell near civilized regions are seen as mostly harmless, gnomes who live in the deeper parts of the world, where their survival is earned by daily struggle, are known to turn their keen minds more toward survival than games. Nothing demonstrates this better than this trap, which kills in a manner that is both inefficient and very unpleasant. This trap is difficult for non-gnomes to construct, but those who have conquered a gnomish realm may find it possible to at least keep the trap maintained and functioning.

A standard floor trigger initially sets off the trap. This activates a massive vacuum pump, which draws the person standing on the trigger upwards into a winding shaft. The same mechanism that drives the pump also drives a large rotating fan blade, which is mounted at the end of the shaft. The victim is pulled onto the blade, which proceeds to slice and dice, with the resulting mess being dumped into a feeding pit. The animals in the pit are usually of a type used as guard or hunting beasts. The trap is not their main source of sustenance, just the occasional tasty treat.

Anyone dumped onto the blades takes 6d6 points of damage before being dumped into the room beyond. The fan mechanism is fairly complex, and if the victim can deal 25 points of damage to it with a suitable weapon, it can be stopped. Unfortunately, dealing 30 or more points of damage also drops the blade and pump mechanism down into the room below, where the beasts therein lunge to the attack.

The trap can only grab one victim at a time, and after it spits the victim into the room beyond it takes it one round to get back to speed. So, there is a two round gap after the trap has claimed its first victim in which characters can traverse the shaft and sabotage the trap. All checks made on the second round, however, are made with a -2 circumstance penalty due to the suction created by the blades. On the third round and each round beyond, a Reflex save (DC 16) must be made to avoid being pulled into the blades.

Detecting this trap usually involves noticing the pressure switch located under the suspicious hole in the ceiling. Gnomes often disguise this with an illusion, however. Disarming the trap consists of disabling the trigger mech-

anism, but, once the trap has been activated, disarming the trigger does no good. Anyone not caught in the fan can attempt to disable the fan mechanism itself, but they suffer the dangers and penalties described above.

## GORE-EYE'S ELEVATOR

**Trap Type:** Elevator Room  
**Construction Type:** Complex mechanical  
**Activation Type:** Extended  
**Trigger:** Local; switch  
**Mechanism:** Counterweight, gear  
**Effect:** Movement, identification  
**Attack Bonus:** No attack roll necessary  
**Damage:** None  
**Save:** None  
**Search DC:** 30  
**Disable Device DC:** 35  
**Challenge Rating:** 6  
**Construction Time/Cost:** 6 weeks; 6,000 gp

This octagonal chamber is best set in some corner of a dungeon. It appears to be a solidly built eight-sided room with only one way in or out. The other seven walls have carved archways decorating them, but only solid stone within each arch. The trigger for the trap is built into the entrance door, and it is both extremely well concealed and difficult to bypass.

When the door is opened a pressure switch between the door and jamb is released. Moulding around the corridor side of the door (which opens into the room) makes it difficult to peer or probe between the door and the jamb, and also conceals the portal's hinges. When pressure is removed from the switch, it opens a plug concealed in the wall that allows sand to slowly pour into a container attached to a lever. One minute after the plug is opened, the container holds sufficient sand to pull the lever down, activating the elevator and emptying the container at the same time. This in turn activates the complex of gears that lowers the entire chamber slowly down to the first stop. The chamber's descent is quite noticeable, but is not in and of itself dangerous as it moves down at a leisurely pace. Observant characters may notice that the walls within the archways appear to be sliding upward.

Two rounds later, at the first stop, the seven archways open into small chambers. Within each space is a single undead monster (DM's choice). The entryway is, at this point blocked



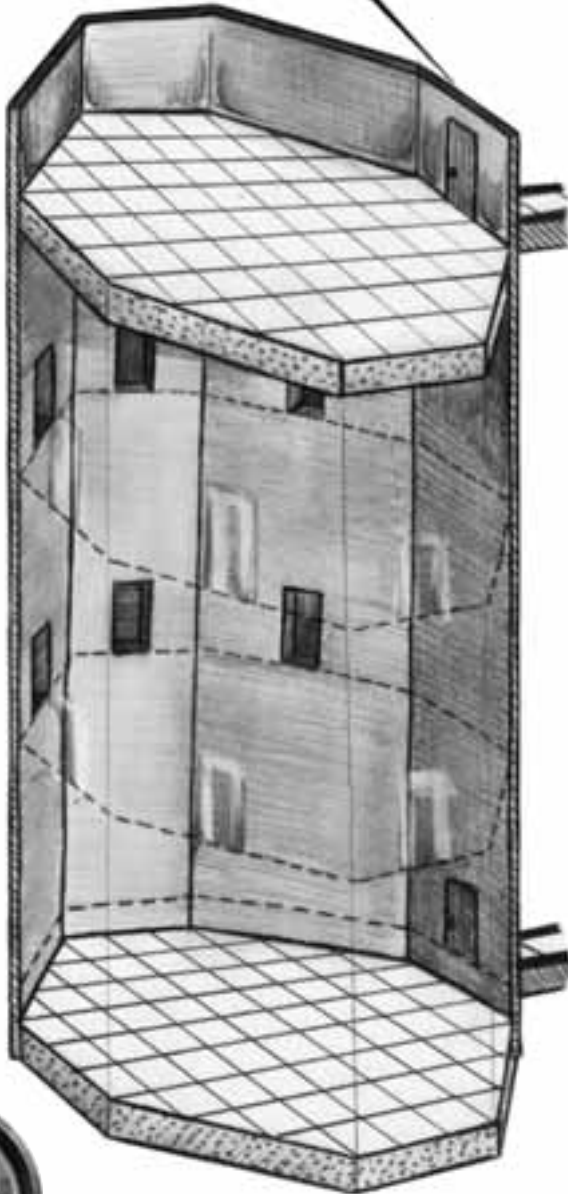

by solid stone. The chamber remains at this level for five rounds and then descends again, taking two more rounds to reach the second stop. Once again, the seven archways open into small spaces holding undead monsters. The chamber lingers at the second stop point for another five rounds, and then completes its descent with another two round drop.

At the bottom of the shaft through which the chamber descends, the arch opposite the entryway opens into a corridor leading into a lower, more deadly level of the dungeon complex. After five minutes, a series of counterweights and gears slowly raise the chamber back to its original location. Unfortunately, the elevator cannot descend again until the sand and lever mechanism is manually reset.

Finding the trap involves noticing the concealed pressure switch before the door is opened so far that the switch is no longer held in place, or else finding the concealed panel that gives access to the lever and sand trap within the wall. The rogue must either successfully jam the switch, or else open the panel (Open Lock check DC 28) and disable the lever. Against a party too proficient at turning undead, the DM may want to substitute constructs for the characters to fight.

## GORE-EYE'S PILEDRIVER

**Trap Type:** Corridor Trap

**Construction Type:** Complex mechanical

**Activation Type:** Extended

**Trigger:** Remote; switch, trapdoor, and pressure plate

**Mechanism:** Gravity, gear

**Effect:** Injury, identification

**Attack Bonus:** No attack roll necessary

**Damage:** 6d6 piledriver, 1d6 pit, drowning

**Save:** Reflex save (DC 20) avoids

**Search DC:** 25 (door), 28 (corridor)

**Disable Device DC:** 25

**Challenge Rating:** 6

**Construction Time/Cost:** 6 weeks; 6,000 gp

Clan Gore-Eye, a devilishly clever extended goblin family, has for decades done one thing well: crafted traps. They are highly regarded by those wicked and rich enough to pay for their services; the Piledriver is just one example of their twisted imagination. This trap works best in an underground corridor where it can protect ingress to an area of special importance.

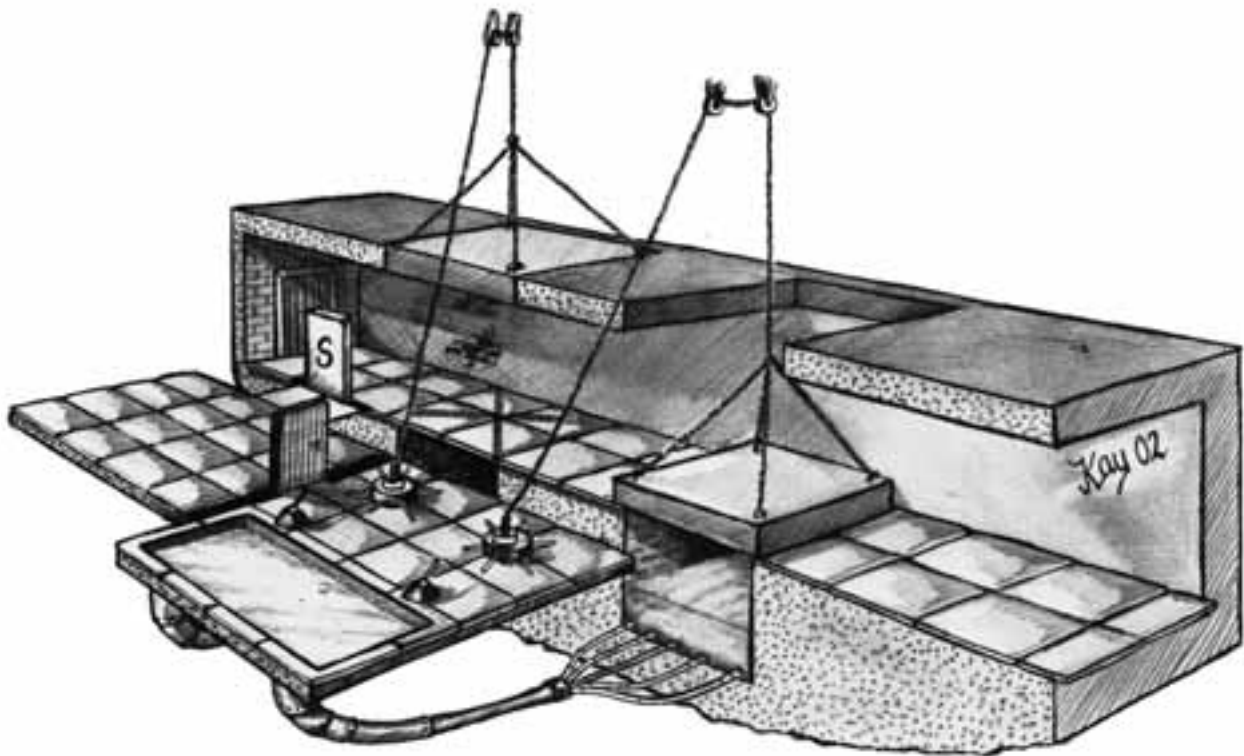

Guards posted in a nearby secret room add a further complication. The means to reset the trap are located in the wheelroom adjacent to the secret guardroom. When activated, the Piledriver can damage and entrap party members, separating adventurers from each other, and alerting the guards that intruders are present.

The trap's switch is the lock mechanism of the door at the end of the corridor. The lock itself is complicated (Open Lock check DC 25), and requires the use of a specially designed key to open without triggering the trap. The key is typically held by one of the nearby guards. An iron spool wound with steel wire lies behind the door. It is attached to a simple but sturdy gear system within the corridor wall. If the trap is not disabled before the door is opened, the iron spool remains taut. Opening the door then pulls the gear trigger, which causes the piledrivers in the corridor to drop.

The piledrivers consist of two massive stone blocks, each positioned over a trapdoor that covers a 10-ft.-deep pit. The trapdoors are smaller than the piledrivers, but still extend across nearly the entire corridor. An exceptionally observant rogue (Spot check DC 25) may notice the trapdoors and piledrivers, but little can be done to disable them. The piledrivers are enormously heavy, and the trapdoors are

designed to open under no less than 750 lb. of pressure. Of course, knowing the locations of the trapdoors makes avoiding them a snap should the trap be triggered.

When the trap is triggered, the piledrivers are unlocked and they drop to the floor. A successful Reflex save (DC 20) avoids the falling blocks completely, but those who fail suffer 6d6 points of damage and are thrown down into the pits below. Regardless, the thunderous impact of the piledrivers alerts the nearby guards. The floor of each pit is a pressure plate connected to the cistern in the wheelroom. When one of them is opened, it creates a rush of water into the pits through dozens of holes in the walls. One foot of water enters the pits each round, starting the round after the piledrivers drop.

The secret door to the guardroom (Search check DC 25) lies between the trapped door and the closest piledriver. Adjacent to the guardroom, which is built about 5 ft. higher than the corridor, is the wheelroom. This room contains two sturdy wheels that are used to pull the piledrivers back into their locked position in the ceiling, as well as a pump that is used to drain water from the pits back into the cistern. Each wheel raises its respective piledriver one foot per round.

Disabling the trap requires somehow severing the link between the door and the gear system within the wall. Applying pressure to the lock's internal switch allows the wheel within the door to play out slack to the steel wire when the door is opened. This method does not permanently disable the trap, however. Once the door is open, the steel wire is visible between the door and the jamb. At this time, the wire can be severed without activating the trap.

## GUARD SPOOF

**Trap Type:** Misdirection Trap  
**Construction Type:** Magic, simple mechanical  
**Activation Type:** Instant  
**Trigger:** Local; magic  
**Mechanism:** Magic  
**Effect:** Hindrance, identification  
**Attack Bonus:** No attack roll necessary  
**Damage:** None  
**Save:** Will save (DC 16) to disbelieve  
**Search DC:** 31  
**Disable Device DC:** 31  
**Challenge Rating:** 6  
**Construction Time/Cost:** 3 days; 3,000 gp; 120 XP

The Guard SpooF is a simple trap that can cause considerable confusion. The design is suited for a wide range of environs, from forest paths to dark tombs. Combined with an alarm, it can work as a delaying factor, distracting intruders while guards approach from another direction.

The spell trap is triggered by pressure placed on a specific area, and it casts a *programmed image* in addition to alerting nearby guards. The illusion creates sounds of voices around a bend. Then it creates a quick image of guards coming into view, looking surprised, and then ducking back out of sight. In a crypt, it may be a sound of shuffling undead stepping into sight and then retreating.

In either case, characters can check for surprise and roll initiative normally. Unless the characters were somehow not surprised (a *foresight* spell, for example) then the illusory creatures should have time to retreat before they can be interacted with. If the characters get initiative, a successful attack quickly reveals the illusion. Regardless of what happens, the illusory guards react in the same way and retreat.

A character placed far enough ahead of the rest of the party can see things from a different angle. It might be obvious that the guards or monsters appeared out of nowhere, and the character may see them disappear once they retreat. This could be a clue that it is merely an illusion.

The trap is quite hard to spot normally. The patterns of dots that make up the glyphs look much like normal spots along the walls. Disabling the trap requires a delicate touch, applying carefully timed taps to set up a destructive resonance in the magic of the trigger.

## JESTER'S GAME

**Trap Type:** Magical Gas Trap  
**Construction Type:** Simple mechanical, magic  
**Activation Type:** Extended  
**Trigger:** Local; magic  
**Mechanism:** Magic  
**Effect:** Injury  
**Attack Bonus:** No attack roll necessary  
**Damage:** Poison (1d4 Wisdom/2d6 Wisdom)  
**Save:** Will save (DC 16) negates  
**Search DC:** 30  
**Disable Device DC:** 30  
**Challenge Rating:** 6  
**Construction Time/Cost:** 4 weeks; 4,500 gp; 180 XP.

The Jester's Game is a deadly trap that utilizes a combination of dangerous magic and poisonous gas to punish trespassers.

This trap is placed in a 15 ft. by 15 ft. stone room found within a stronghold, dungeon complex, or castle. Typically, the room will have only one entryway and no exits, although variations of this trap do exist. Placed inside of the room is a large wall carving of a court jester. This carving depicts either a jester of the creator's race or, more commonly, that of a race for which the creator holds a particular hatred. To lure in the curious, the jester is adorned with valuable gems worth no less than 500 gp each. It is recommended to use real gems as a clever jewel cutter may quickly spot a fake. A successful Appraise check (DC 15) allows a character to identify the genuine nature of the jester's inset gems.

The trap is activated when a character steps within 10 feet of the jester carving. This acti-

vates a *feblemind* spell stored within one of the gems set into the carving. A successful Will save (DC 16) allows a character to avoid the spell effect. Additionally, the magic gem radiates a moderate Enchantment aura if *detect magic* is used.

The second step is a series of simple counterweights that drop a stone slab over the entryway to the jester's chamber. A successful Strength check (DC 22) is required to lift the slab. Any character under the passage threshold when the slab is activated must make a successful Reflex save (DC 15) or take 4d6 points of damage and be considered pinned.

Once the slab has fallen, a *magic mouth* spell placed on the jester's mouth activates and asks a question that characters stricken with the *feblemind* spell should not be able to answer easily. An example of this question may include:

*"How many eyes does an eye tyrant have?"*

If a character answers the question correctly, the slab is lifted and the trap disarms. If a character answers incorrectly, a poisonous gas is released from the fingertips of the jester carving. The gas fills the room in five rounds and

acts exactly as insanity mist (DMG 80). The gas extinguishes oxygen, thus creating a suffocation danger (DMG 88).

A rogue may notice the faint smell of the poisoned gas or notice the small holes in each of the jester's fingertips. The easiest method is to simply avoid the jester completely if possible, but a rogue may also jam the top of the entryway with a sturdy object to prevent the slab from trapping her within the room. Also, destroying the magic-laced gem diffuses the trap as well.

## PIT OF BROKEN STATUES

**Trap Type:** Magical Pitfall

**Construction Type:** Simple mechanical, magic

**Activation Type:** Extended

**Trigger:** Local; trapdoor, magic

**Mechanism:** Gravity, magic

**Effect:** Petrification, injury, ensnarement

**Attack Bonus:** No attack roll necessary

**Damage:** 1d3 subdual damage

**Save:** Special

**Search DC:** 25

**Disable Device DC:** 25

**Challenge Rating:** 6

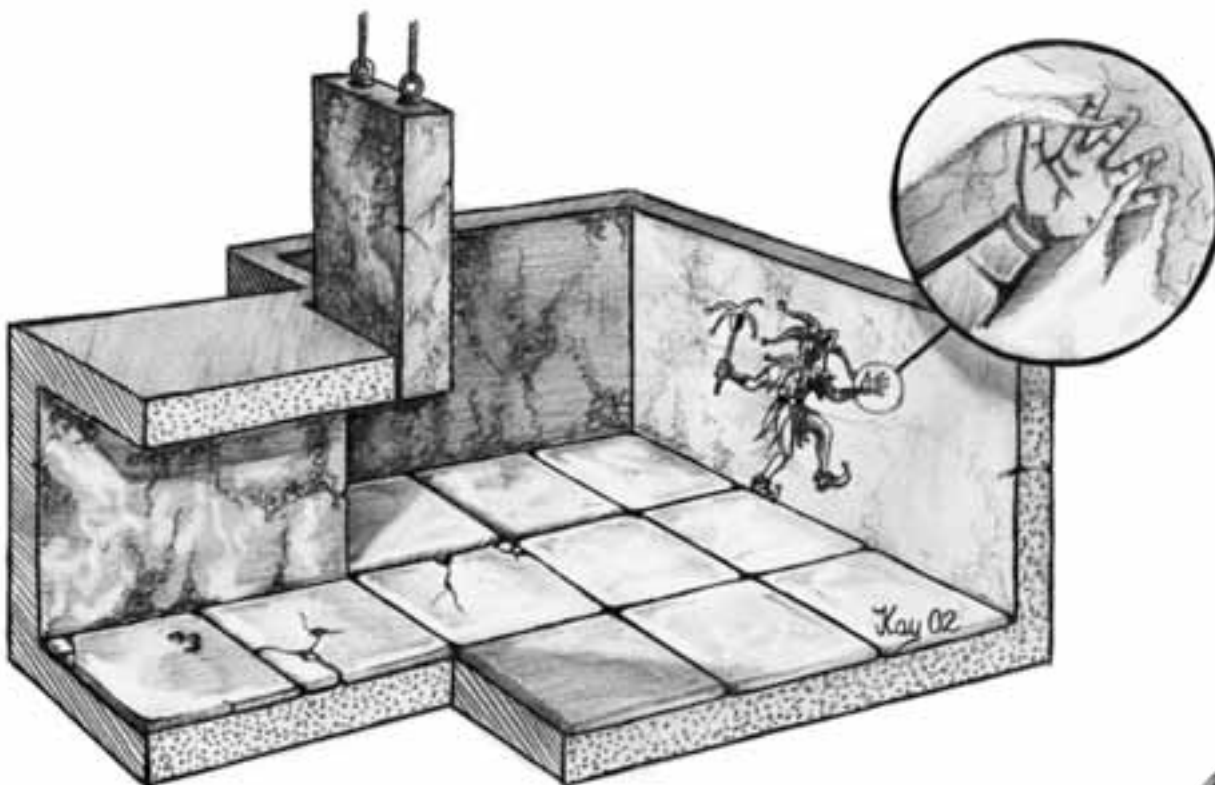



**Construction Time/Cost:** 6 days; 3,000 gp; 120 XP

It is not difficult to escape from most pitfalls if the character both survives the fall and has allies nearby. The Pit of Drowned Statues, however, adds a little complication to the scenario; it turns its victims to stone before dropping them into a deep pool filled with other statues. This trap is favored by certain high-powered mages who are given to long trips and who like to keep intruders preserved for a long, enjoyable interrogation session when they get back.

The Pit of Broken Statues is in most respects a conventional pit trap. When it is triggered, a concealed trapdoor pops open, dropping those standing on it down a 30-ft. deep shaft. Characters can avoid falling in the pit with a Reflex save (DC 20). After falling 10 feet down the shaft, the victims pass through a field that turns organic matter into stone. It requires a Fortitude save (DC 16) to avoid this effect.

The petrified and non-petrified alike drop another 20 feet into a 40-ft. deep pool of brackish water; the trapdoor, meanwhile, closes and locks itself.

Needless to say, the bottom of this pool is littered with statuary. Some of these statues are the remains of former victims of the trap, while others are mundane statues crafted to look like victims. Characters may find it a challenge to immediately locate fallen comrades by fumbling around in the dark, deep water. A few Search checks may be required to turn up the right statue, and the only way to identify the correct one is to haul each statue up to the surface one at a time.

The trap's weakness is of course its trapdoor. Although cunningly hidden, it is still a mundane trapdoor that can simply be avoided or jammed shut.

## SPRING AND WINTER

**Trap Type:** Floor Trap

**Construction Type:** Magic

**Activation Type:** Instant

**Trigger:** Local; magic

**Mechanism:** Magic

**Effect:** Ensnarement

**Attack Bonus:** No attack roll necessary

**Damage:** None

**Save:** None

**Search DC:** 31

**Disable Device DC:** 31

**Challenge Rating:** 6

**Construction Time/Cost:** 6 days; 3,000 gp; 120 XP

This is a rather straightforward trap that can be set up in a corridor or room. There are two sigils on the wall; both are part of more complex designs and usually remain hidden without a good search or *detect magic*. When either is activated, it casts *transmute rock to mud* on the floor, turning it into mud to a depth of 10 feet as per the usual functioning of the spell. This slows characters down as normal for the spell.

Triggering the second rune, by moving within the mud for example, causes an effect similar to the *heat metal* spell to fill the muddy area. Note that if the characters have somehow managed to use mats and other material to float on the mud, they will only be momentarily inconvenienced.

Each trigger has an active detection area 5 ft. wide and 10 ft. tall. This area extends to the far wall, and relies on magical darkvision to detect intruders. Once activated, a trigger does not reset until there are no creatures within view or five hours have passed. After five hours, any being in view is ignored until it has left the area.

The effect alternates, so the direction from which a character approaches does not matter. Also, if a character moves into the detection area, leaves, and then returns, the next effect is triggered. A character can remain in the detection space of one trigger while another character enters the space of the other trigger. This results in the next effect in sequence.

This trap is often combined with guardian creatures to increase its deadliness. Such creatures are either taught to avoid the sigils or have means to attack trapped characters without entering the area. Often creatures with fire resistance are used so that they can attack trapped characters without suffering the effects of the heated area.

A rogue can disable either sigil by chipping away the stone around it. One disabled trigger does not mitigate all of the danger, however. Only when both are disabled is the trap completely neutralized.

This is a useful trap for tombs and other installations. It is less useful for buildings that see a great deal of foot traffic, though beings capable of flight or invisibility might find it useful. In the case of flying creatures, the room or corridor can be built with a high ceiling so the creatures can avoid the triggers and not waste the magic.

Other options include castle defenses, where a guard may have a simple touch activated plate to turn an area near the castle into mud; pressing it again turns the area back to stone. Internal areas may be equipped with such switches, granting a defensive edge to prepared and magically equipped defenders.

*By the gods! There we were, about to exit the fabled Tomb of Thor's Abyss when the damned corridor turned into a cauldron of goo. What's worse, someone decided that would be a good moment to turn up the heat! That damned mud burned into my skin until all I could do was shed my armor and run for the exit!*

-- Hekrod Jalabar, mercenary

## STORMCHASED

**Trap Type:** Weather Trap  
**Construction Type:** Magic  
**Activation Type:** Instant  
**Trigger:** Local; magic  
**Mechanism:** Magic  
**Effect:** Hindrance  
**Attack Bonus:** No attack roll necessary  
**Damage:** None  
**Save:** None  
**Search DC:** 31  
**Disable Device DC:** 31  
**Challenge Rating:** 6  
**Construction Time/Cost:** 3 days; 3,000 gp; 60 XP

This spell trap is designed to curse an item. Clever characters may find ways to turn the effect to their advantage, however. The service of mages or scholars is crucial in identifying the magic used, the source of the magic, and ideas on how to handle it. Finding the key phrase can make this a positive rather than negative effect.

The spell trap activates when touched by someone without the utterance of a key phrase. It casts *control weather*, turning the nearby weather as hostile as possible for the season. Tornadoes, torrential rains, sleet, blizzards, and hurricanes are the most likely choices. If the weather is already bad, the magic makes it worse.

It takes 20 minutes for the weather to be affected, and it lasts for 4d12 hours thereafter. The weather created is centered on the item, spanning two miles in every direction. A character that moves with the item brings the weather with him.

A character carrying this item in a pack does not trigger the item until he next touches it, and only one triggered effect applies at a time. If the character can learn the key phrase associated with the trapped item, he can handle the item normally whenever he wishes.

The spidery traces of this spell are only clear to an experienced rogue. Disabling the trap requires a bit of pine pitch applied to specific points on the rune. The result of accidentally triggering the trap is somewhat milder than that of other traps, though it can still cause quite a stir for those around the bearer.

## SURPRISING BLADES

**Trap Type:** Blocking Trap  
**Construction Type:** Magic  
**Activation Type:** Instant  
**Trigger:** Local; magic  
**Mechanism:** Magic  
**Effect:** Ensnarement, hindrance  
**Attack Bonus:** No attack roll necessary  
**Damage:** 11d6  
**Save:** Reflex save (DC 19) negates  
**Search DC:** 31  
**Disable Device DC:** 31  
**Challenge Rating:** 6  
**Construction Time/Cost:** 3 days; 3,000 gp; 120 XP

This potentially deadly trap is mostly intended to startle unwanted guests, hopefully causing them to reconsider their foray. It is common in temples of war gods, as a way of testing the mettle of intruders. Bravery and steel nerves are respected, even if people are intent on theft.

The trap is typically placed down a corridor, just before a locked door. As the door is approached, the trap casts *blade barrier* just behind the trigger. The trigger reacts to anything visibly moving through the area, so may be confounded by *invisibility* or *darkness*. The blade whirls horizontally, making it impossible to pass without damage. If someone was standing behind the character, in the way of the blade, a Reflex save is necessary to avoid damage.

The safest course of action is for the person stuck between blade and door to simply wait 110 minutes until the blade vanishes. Alternately, the blade can be dispelled. The trap is set so that it does not go off until 30 minutes after the end of the previous activation.

The locked door requires an Open Lock check (DC 20) to bypass. Once open, it reveals a simple stone wall. There are no secret panels and the door is not intended to lead anywhere. *Stone shape* or other spells may be able to open this wall to a crossing corridor beyond, depending on layout of the structure in which it is found.

The biggest initial clue to an observant character is the lack of wear on the floor leading in this direction. This is a common sign that nobody normally uses the passage, but it is not definitive, since it could also indicate that acolytes and petitioners are not allowed in the area. Wear depends on the material of the floor, age, and how accessible the place is. An observant rogue can spot the inlaid designs along the walls, subtle icons that draw on divine power. A muttered prayer combined with casting salt onto the two power symbols disrupts the aura that forms the spell.

## THE KILLING KILN

**Trap Type:** Fire Shower Trap  
**Construction Type:** Complex mechanical  
**Activation Type:** Instant  
**Trigger:** Local; trapdoor  
**Mechanism:** Gravity, pressure  
**Effect:** Ensnarement, injury  
**Attack Bonus:** No attack roll necessary  
**Damage:** 6d6  
**Save:** Reflex save (DC 22) avoids  
**Search DC:** 22  
**Disable Device DC:** 22  
**Challenge Rating:** 6  
**Construction Time/Cost:** 6 weeks; 6,000 gp

The Killing Kiln is a sinister, yet simple trap that uses an oiled stone chute and alchemist's fire to ignite the curious or punish slow-footed thieves.

This trap is most often placed within strongholds and dungeon complexes. The first step of this trap is activated when a character steps onto the trapdoor mechanism located above the oiled chute. A successful Reflex save (DC 22) is required for a character to avoid the opening trapdoor. A character that fails her saving throw is sent down to the bottom of the 30-ft.-deep, oiled chute. The opening of the trapdoor activates a secondary mechanism that releases alchemist's fire into the bottom of the chute. The alchemist's fire ignites the oil lining the chute and causes 6d6 points of damage to anyone inside.

The second effect of this trap is the oiled chute, which not only serves as a lubrication agent, but also ignites when contacted by the alchemist's fire. The oiled chute only burns for one minute before the oil is spent due to the reaction of the alchemist's fire. A character trapped at the bottom of the chute must make a successful Climb check (DC 24) to escape. If the chute is still on fire, the character suffers 1d6 points of damage for every 10 feet she travels.

This is a one-use trap, requiring extensive work to reset. The alchemist's fire must be replaced, the walls of the pit coated with oil, and the trapdoors and pressure plate reset.

An observant rogue may notice the trapdoor within a passage floor or smell the faint odor of the oil-coated chute. To disarm the trap, a rogue need only avoid the trapdoor or jam the trapdoor mechanism.

## UP AND AWAY

**Trap Type:** False Ladder Trap  
**Construction Type:** Complex mechanical  
**Activation Type:** Extended  
**Trigger:** Local; switch  
**Mechanism:** Spring  
**Effect:** Injury  
**Attack Bonus:** No attack roll necessary  
**Damage:** See below  
**Save:** See below  
**Search DC:** 25  
**Disable Device DC:** 30  
**Challenge Rating:** 6  
**Construction Time/Cost:** 6 weeks; 6,000 gp

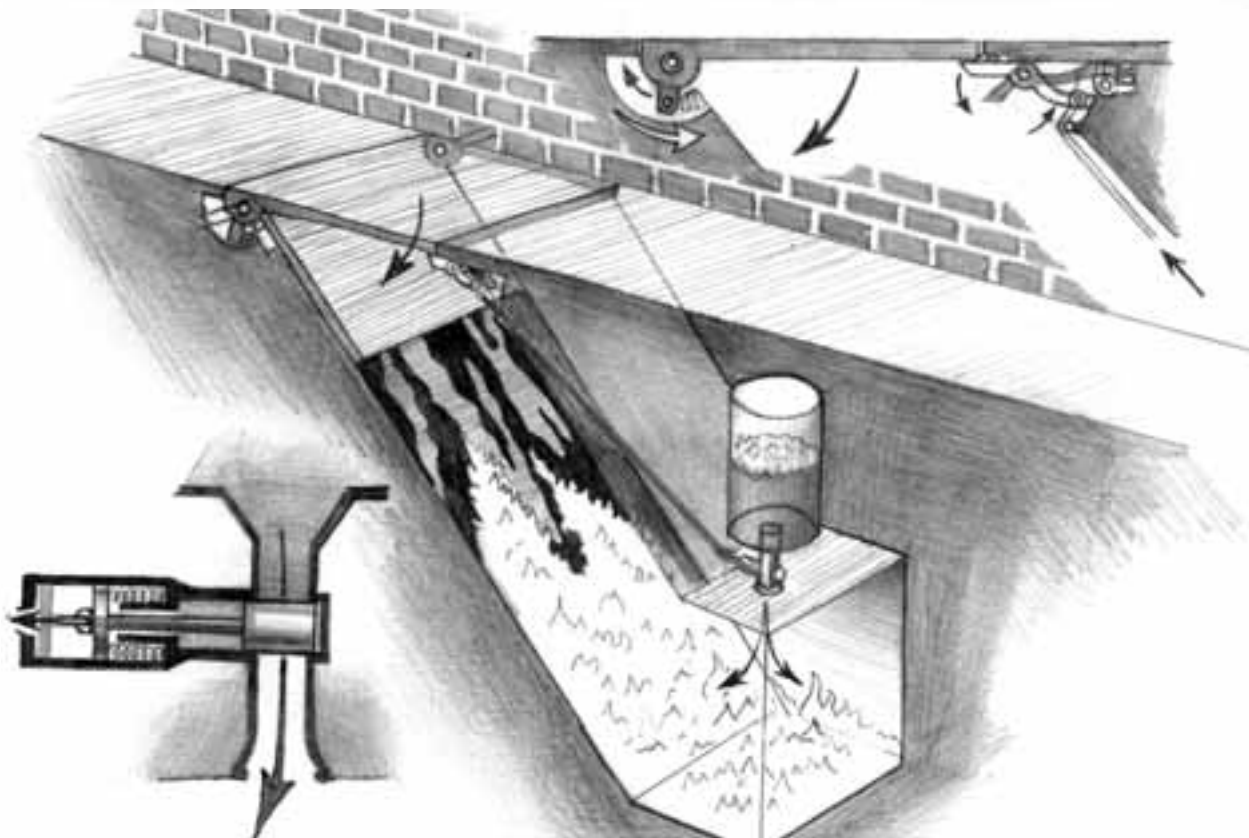

This metal, pole-type ladder is typically encountered in a cavern or other tall room. It is sturdy and has alternating rungs on either side of the central pole, and can easily support weights in excess of 300 lb. There is no obvious flaw or fault with the ladder from ground level, encouraging the adventurers to proceed up the ladder at a brisk pace.

Approximately 60 feet above the ground is a rung that is actually the trigger for this particular trap. While detecting the trigger itself is not easy, disabling it is considerably more difficult as it can only be seen and disabled by a character that is adjacent to the rung itself. Avoiding the rung is easy for Medium-size adventurers, but smaller individuals will find climbing beyond the trapped rung a bit more difficult (Climb check DC 10).

If the rung is used, it snaps into the body of the pole with an audible click. Whoever broke the rung must make a Climb check (DC 15) to avoid falling just from triggering the trap. Once the trap is set in motion, a variety of effects are available to the DM:

- All rungs are suddenly released from the central pole, plunging the party to the ground below and putting the room above out of reach. Determine damage as per the falling rules in the core rules (DMG 112).
- Boiling oil is released from above, dousing anyone on the ladder or within 10 ft. of its base, dealing 4d6 points of damage and making the pole incredibly slippery (Climb check DC 25).
- The ladder begins to spin faster and faster, threatening to fling the characters off and onto the sharp stalagmites below. Adventurers must make Climb checks each round in order to hang on to the ladder. The checks start at DC 10 and add 5 to the DC each round until the total DC reaches 30, at which time the ladder begins to slow down, necessitating more Climb checks that get progressively easier until the ladder stops spinning.
- An electrical shock shoots through the ladder. Anyone not fully protected (leather gloves and boots) takes 5d6 points of damage and must make a Fortitude save (DC 20) to keep from being flung off the ladder. Anyone wearing non-metallic gloves and boots receives half damage.

## Wind Moat

**Trap Type:** Siege Trap  
**Construction Type:** Magic  
**Activation Type:** Instant  
**Trigger:** Magic  
**Mechanism:** Magic  
**Effect:** Hindrance  
**Attack Bonus:** No attack roll necessary  
**Damage:** None  
**Save:** None  
**Search DC:** 31  
**Disable Device DC:** Special  
**Challenge Rating:** 6  
**Construction Time/Cost:** 6 days; 3,000 gp; 120 XP

In a siege, the greatest non-magical danger faced by those that man castle or city walls are arrows and other missile attacks. The Wind Moat harnesses the power of the *wind wall* spell to blow light missile weapons off course, protecting defenders from sniper attacks as well as larger assaults.

The Wind Moat's power is lodged in keystones set in the wall in front of which the trap is set to function. One stone powers the spell for the length and width dictated by the *wind wall*

spell. The default trap is set to protect an area 30 ft. high and 60 ft. long, and requires a spell-caster of 6th level or higher to initiate. Additional keystones may be spaced out to cover a longer wall, but the *wind wall* must be cast at a higher level to increase height. This is not usually necessary, since the keystones are often placed high up the wall to provide maximum coverage.

Detecting the trap is difficult because the runes powering its magic are engraved on the side of the keystone facing into the wall. If the Wind Moat was added retroactively to a pre-existing wall (which is often the case), discerning individuals may detect stones slightly different in coloration or texture from those around them, marking a keystone that was added to a wall much later than its neighbors.

Disarming the trap is simple, at least in theory. When a keystone is removed from the wall, the trap ceases to function in the area the stone was protecting. Of course, removing the stone is easier said than done. They are usually located at an inconvenient height, often 30 ft. up, and defenders almost always take exception to a rogue scaling the wall to chip it out.

Note: Defenders desiring to create walls with a



height of greater than 30 feet may cast the *wind wall* spell at a higher level. The spell must be cast at 8th level for a wind wall 40 ft. high and 80 ft. long, and at 10th level for a wind wall 50 ft. high and 100 ft. long, for example. This will of course increase the CR, construction time, and cost of the trap: CR 8; 8 days; 4,000 gp; 160 XP in the former case, and CR 10; 10 days; 5,000 gp; 200 XP in the latter.

## AUTOGARROTE

**Trap Type:** Strangulation Trap  
**Construction Type:** Complex mechanical  
**Activation Type:** Extended  
**Trigger:** Local; switch  
**Mechanism:** Counterweight, gears  
**Effect:** Ensnarement, injury  
**Attack Bonus:** No attack roll necessary  
**Damage:** 4d6 plus strangulation  
**Save:** Reflex save (DC 20) avoids  
**Search DC:** 26  
**Disable Device DC:** 31  
**Challenge Rating:** 7  
**Construction Time/Cost:** 7 weeks; 7,110 gp

A complex trap designed more for elegance than practicality, the Autogarrote combines sophisticated use of light sensors with simple, counterweight-driven armatures. It is most useful in interior corridors, particularly narrow ones.

The initial switch is a simple pressure plate that activates the mechanism. There are numerous small holes on either side of the plate within the wall. Beginning about four feet up on the walls, the holes act as the central sensor of the mechanism. If the pressure plate is activated but there is nobody blocking light four feet or above, then the mechanism does not activate.

A disc-shaped container inside one wall holds a *continual flame* spell. From it protrudes a series of tubes with lenses. These tubes straighten the light and the light is projected from one hole to its mate on the opposite wall through a series of small mirrors.

In the second set of holes are numerous sensors. These are based on a material that has one shape in light and another in darkness. The effect is to act as a series of relays, through gears that move between one state and another. The gears are constructed to react only to the highest sensor that darkens, thus predicting the height of an intruder.

This setting is transferred to the armatures holding the garrote. The device slides down to a distance one foot below the estimated height, then the entire assembly is pulled rapidly through a section of corridor. A character within the affected space must make a Reflex save (DC 18) to avoid the wire. Failure indicates the character takes 4d6 points of damage.

If a number of conditions are right, the wire also strangles the character, trapping him against the ceiling. A character with a tall hat might have the garrote swing above his head, while one in full plate with a helmet may deflect the blow. The other common case is a character walking in the opposite direction, so that the wire hits the back of the neck.

When conditions are not ideal for the trap, the character gets an additional Reflex save (DC 16). Otherwise, the character is caught.

A garroted character is pushed back and then pulled up to the ceiling as the mechanism tries to reach its end position. The character takes an additional 1d6 points of damage, then starts suffocating (DMG 88).

The wire is hardness 5, hp 5. The trick is cutting the wire without causing any further damage to the trapped character. Damage dealt by a weapon also deals damage to the character, unless the attack result is 30 or more. A better alternative is a Craft (trapmaking) check (DC 15). This removes the wire, though the character still takes 1d6 points of damage as it slides off his throat. If the result is 20 or greater, the wire is removed with no further damage.

A final result of being garroted is that the character's voice is considered damaged. The character cannot talk except in a hoarse whisper. This makes it difficult to communicate in some situations, and imposes a 15% arcane spell failure chance on spellcasters. The damaged voice lasts until treated with a Heal check (DC 15), a day of rest, or at least one point of magical healing.

The pressure plate is fairly easy to notice, as are the grooves in the ceiling. Though both can be disguised by repetition elsewhere, an attentive observer can note the differences between an engraved line and a mechanical track. The holes may be suspected as exits for darts or poison. The light passing through

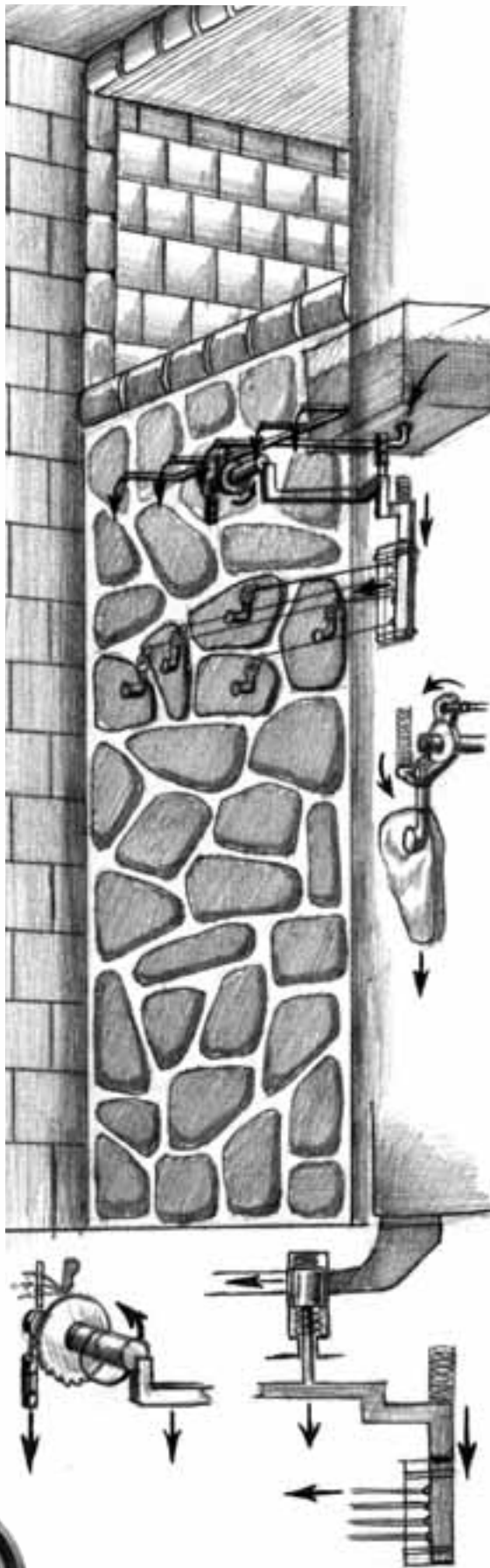

might be understood, along with the faint clicking when objects pass within the light (from the sensors shifting).

The trap requires great skill to engineer, but the mechanism does not require significant maintenance. The counterweight, however, must be reset after five uses. It is expected that the device will require attention to replace garrote wires or clear bodies, so a robust design is not as vital. Gnomes particularly enjoy this trap, as they are able to evade it simply by keeping their heads down.

## BURNING WALL

**Trap Type:** Burning Oil Trap  
**Construction Type:** Complex mechanical  
**Activation Type:** Instant  
**Trigger:** Local; switch  
**Mechanism:** Gear  
**Effect:** Injury  
**Attack Bonus:** No attack roll necessary  
**Damage:** 4d6  
**Save:** Reflex save (DC 20) to avoid  
**Search DC:** 28  
**Disable Device DC:** 28  
**Challenge Rating:** 7  
**Construction Time/Cost:** 7 weeks; 7,000 gp

This trap is similar in many ways to the Falling Wall. Indeed, it is most effective if used after the party has already encountered that trap.

The trap does not activate until a climber is roughly two thirds of the way up the wall. Then, there is an ominous click, followed by a slight dripping sound. A sheet of glistening oil comes sliding down from the top of the wall, coating the rocks and most likely the character. A Reflex save (DC 20) at this point allows the character to leap away from the wall, though falling remains a problem. After allowing the character to make the save, the oil ignites, engulfing the wall in a sheet of fire.

Anyone climbing the wall takes 4d6 points of fire damage and must make a Fortitude save (DC 15) to continue holding on to the wall. On the next round, the character takes 2d6 points of fire damage and must again make a Fortitude save (DC 15) to stay on the wall. (The reason for calling for a Fortitude save rather than a Climb check is that the character is presumably not trying to move, but is simply holding on to the wall. If the character attempts to continue

climbing while on fire, the DC of the Climb check increases by the number of points of damage taken.)

Detecting and disarming this trap is very difficult. The mechanism is high up the wall, and, delicate work must be done to block or disarm it while trying to cling to the wall. A Climb check (DC 15) must be made prior to each Disable Device check; failure indicates that the character falls. Another option is to attempt to climb the wall while avoiding the numerous trigger points. Doing so requires moving at one-half normal climbing speed and making a Search check (DC 15) each round to avoid accidentally triggering the trap.

Possible hints of this trap that can be seen from the ground would be odd stains on the floor, scorch marks on the bricks, or tiny holes just barely visible in some of the higher bricks of the wall.

## COLD FEET

**Trap Type:** Cold Magic and Monster Trap  
**Construction Type:** Magic  
**Activation Type:** Instant  
**Trigger:** Local; magic  
**Mechanism:** Magic  
**Effect:** Ensnarement, injury  
**Attack Bonus:** No attack roll necessary  
**Damage:** See below  
**Save:** None  
**Search DC:** 31  
**Disable Device DC:** 31  
**Challenge Rating:** 7  
**Construction Time/Cost:** 5 days; 5,500 gp; 220 XP

Cold feet is a magical trap designed to turn a seemingly innocuous dungeon feature into a crippling encounter. An empty stream or shallow pool of water is suddenly turned into a frenzied feeding ground for a swarm of fiendish piranha.

This trap looks quite innocent at first, and should be placed near a natural stream or other place where shallow water may look natural. The water crossing is 15 ft. wide and only 2 ft. deep at its deepest, so the characters should have no trouble crossing it without aid. Once a character reaches the midpoint of the water, the trap is sprung.





## FIENDISH PIRANHA

### Tiny Magical Beast (Aquatic)

**Hit Dice:** ½d8 (2 hp)

**Initiative:** +1 (Dex)

**Speed:** Swim 20 ft.

**AC:** 13 (+2 size, +1 Dex)

**Attacks:** Bite +3 melee

**Damage:** Bite 1d3-3

**Face/Reach:** 2 ½ ft. x 2 ½ ft./0 ft.

**Special Attacks:** Frenzy, smite good

**Special Qualities:** Darkvision 60 ft., cold resistance 5, fire resistance 5

**Saves:** Fort +2, Ref +3, Will +1

**Abilities:** Str 4, Dex 12, Con 10, Int 4, Wis 12, Cha 6

**Skills:** Spot +6, Hide +6\*, Move Silently +6\*

**Feats:** Weapon Finesse (bite)

**Climate/Terrain:** Aquatic

**Organization:** School (5–14) or swarm (15–35)

**Challenge Rating:** 1/4

**Treasure:** None

**Alignment:** Neutral evil

**Advancement:** —

An *otiluke's frozen sphere* (frigid sphere version) is triggered as soon as a character reaches the middle of the pond. The water immediately freezes, trapping the character and any others in the water as detailed in the spell description (PHB 233). At the same moment, a *summon monster* spell sends six fiendish piranhas underneath the frozen surface of the water to feast on trapped characters' feet and legs. Characters who take damage from the piranhas must make a Reflex save (DC 18) each round in which they are damaged or be temporarily lame. Lame characters have their movement rate reduced by 75% and may not run or charge. This lasts until the character receives magical healing or rests for one day for every point of damage suffered.

Noticing this trap is difficult, though cautious rogues may decide to check out the stream or pond before wading through. With a successful Search check (DC 31) the rogue may notice an unnatural cold emanating from nearby walls. In order to disable the trap, the rogue must chisel into the walls and find the white diamond (400 gp) that powers the magical portion of the trap.

This requires another Search check (DC 22) and a half-hour of cutting into the wall. Alternatively, the characters can avoid the

## COMBAT

**Frenzy (Ex):** Piranhas are group hunters that attack their prey in swarms. Once the blood of their prey is in the water, the piranhas attack the wounded creature without mercy before moving on to the next victim. Once any piranha in a swarm hits with its bite attack, each piranha in the swarm takes an extra attack each round against the wounded prey, with both attacks suffering a –2 penalty to hit.

**Smite Good (Su):** Once per day the fiendish piranha can make a normal attack to deal 1 point of additional damage against a good foe.

**Skills:** \*Piranhas receive a +8 bonus to Hide and Move Silently when swimming under the surface of the water.

*The text within this shaded box is designated as Open Game Content.*

trap by finding another way around the water or triggering the trap and walking across the frozen surface.

## DISARMED AND DANGEROUS

**Trap Type:** Weapon Trap

**Construction Type:** Magic

**Activation Type:** Instant

**Trigger:** Local; magic

**Mechanism:** Magic

**Effect:** Injury

**Attack Bonus:** +8 melee

**Damage:** See below

**Save:** Will save (DC 17) resists

**Search DC:** 30

**Disable Device DC:** 30

**Challenge Rating:** 7

**Construction Time/Cost:** 1 week; 4,500 gp; 180 XP

This trap is usually set in a large, high-ceilinged room, though it does not need to be. The room is almost always empty, but placed at a crucial juncture. The spell is triggered when someone passes the centerpoint of the room, and it covers the entire area so all within the room when the spell is triggered are targeted.

Whichever weapons or items are currently readied (held in the hand) are grabbed away by a variant *telekinesis* spell. Essentially the spell makes a Strength check against the character wielding the weapon or item it is trying to grab. The trap is considered to have a Strength of 18 for purposes of this check. If the trap wins this check, the weapon is yanked from the hand of the character and it immediately begins to attack him with an attack bonus of +8. Any magical bonuses the weapon might have apply, but any special features of the weapon that do not automatically activate (in other words, which require a command phrase) are not used. Other weapon properties, such as flaming, shocking burst, and so on, do work. If the weapon is a double weapon, the trap wields it as if it had the Ambidexterity and Two Weapon Fighting feats. Otherwise the trap only makes a single attack per round.

The spell effect lasts for nine rounds. During this time the weapons may be attacked as normal, but most characters will be hesitant to destroy their own weapons. The weapons do not leave the room to pursue the characters, but if the room is vacated and re-entered, the trap resets itself, and the weapons rise to the attack when the characters enter.

Intelligent weapons can make a Will save (DC 17) to resist being wielded against their bearer.

This trap is an interesting way to force characters to rely on secondary weapons, as their favorite weapons will be wielded against them for a short period of time.

## DROP AND BLADE CRAWL

**Trap Type:** Floor Drop and Blade Trap  
**Construction Type:** Complex mechanical  
**Activation Type:** Instant  
**Trigger:** Local; gravity  
**Mechanism:** Counterweight, gravity  
**Effect:** Ensnarement, injury  
**Attack Bonus:** +15 melee  
**Damage:** 8d6  
**Save:** Reflex save (DC 20) avoids  
**Search DC:** 23  
**Disable Device DC:** 26  
**Challenge Rating:** 7  
**Construction Time/Cost:** 7 weeks; 7,000 gp

Gnomes prefer small tunnels. They provide effective barriers against many larger beings,

as well as limiting the speed and capabilities of potential intruders. Typically 3' 6" tall by 3' wide, these tunnels are enough for most gnomes to have a little clearance. Dwarves are forced to stoop, and cannot run down these corridors. Humans and other Medium-size beings can only walk bent over, or may crawl on hands and knees. Such tunnels become terrifying when combined with traps.

This particular design allows gnomes to negotiate safely through tunnels laced with traps, yet remain a deadly threat to intruders. In an area with traps, sigils engraved in the wall provide a hint. Even gnomes unfamiliar with the script learn the dangerous ones, and avoid those areas. A successful Decipher Script check (DC 27) allows a character to figure out the dangerous sigils and to avoid future traps.

The main part of the trap is a simple lever. The floor is loose and set with a pivot and a counterweight, each balanced carefully. A counterweighted catch keeps the floor from moving until a predetermined weight is exerted on it, such as a human crawling out onto it. The floor then swings down, catching the character in a 10-foot drop. A successful Reflex save (DC 20) allows the character to pull back in time to avoid the fall. A second mechanism slides blades out from below, striking a falling character. The design ensures that the action of the blades pins the character to the floor. A successful Escape Artist check (DC 20) allows the character to squeeze free of the blades. Failure by 5 or more indicates the character takes an additional 1d6 points of damage from the blades as well as remaining trapped.

The sigils on the walls near this trap are ubiquitous. If one of the party members is a gnome, she can recognize the sigils and their meaning with a successful Wisdom check (DC 15). A dwarf who knows the Gnome language may also recognize the sigils in a similar manner.

The biggest telltale is simply the break in the floor, where it swings down to trap unwanted visitors. The construction of such moveable floors is also slightly different than the surrounding stonework, another important clue. Additionally, there is a lack of wear marks down this section of corridor, due to avoidance by gnomes. Disarming the trap is a rather simple matter of spiking the floor.

In gnomish labyrinths, there may be a number of these traps. One quirk of the design is that dead victims often stick in the trap, even once skeletal. The gnomes may have clean up patrols to keep disease and odor from passing to well-traveled areas, but areas that have fallen into disuse have grisly remains strewn throughout. Gnomes generally see this as an effective way of deterring unwanted visitors.

## GRENADE CHEST

**Trap Type:** Item Trap  
**Construction Type:** Complex mechanical  
**Activation Type:** Instant  
**Trigger:** Local; switch  
**Mechanism:** Spring, gears, chemical  
**Effect:** Identification, injury  
**Attack Bonus:** No attack roll necessary  
**Damage:** See below  
**Save:** Reflex save (DC 15) partial  
**Search DC:** 26  
**Disable Device DC:** 26  
**Challenge Rating:** 7  
**Construction Time/Cost:** 7 weeks; 7,000 gp

Combining a simple spring mechanism with an explosive device, this is a useful one-shot surprise for would-be thieves. It is intended to kill, or at least seriously injure, anyone who opens the chest improperly. In addition, due to the noise generated, it also acts as a simple alarm. Note that given its price, it will only be used for quite valuable possessions. Value, of course, is relative, as the chest has been used to protect treaties or merchant records as often as gold and jewels.

When the lock is opened (either picked or opened normally), the lid springs open due to a tension spring inside. Then, two chemicals that are stored in the lid are mixed. The reaction causes an explosion, firing many sharp pieces of metal from the inside of the lid in a 15 ft. cone, causing 8d6 points of damage to all within the area; a Reflex save (DC 15) is allowed for half damage.

There is a small slide switch on the inside lip, near the lock, which deactivates the system. Someone opening the chest merely needs to keep a grip on the front handle, let it open a small amount, and then reach in to slide the switch.

The easiest way to detect the trap is that the

lid is slightly loose. A character examining the lock and carefully probing the chest notes that the lid, if pushed down slightly, springs back up. This suggests that it is under tension, and that it will open further once released. Another hint is that the hinge is internal, although this could simply be a secure design.

Once a character has this information, he can automatically keep the lid from swinging fully open. The contents of the chest can be removed while keeping the lid from opening completely, unless he is trying to remove particularly large items. Every round the character is engaged in a complex action, a Reflex save (DC 12) is required to avoid losing his grip on the lid. A complex action is one that involves taking items out or performing any detailed examination of the chest. If the character holding the lid is not taking any other action, and nothing is being done to the chest, no check is needed.

Knowing the functioning of the chest, a thief might suppose there is a deactivation switch. Looking for such a switch on the inside of the chest requires a Search check (DC 20). The switch, when operated, locks the spring. The first noticeable effect is that the lid stops pulling away from the closed position. The lid will not close past this position, but is slack when lifted further. This prevents the explosive mechanism from being activated.

In addition, once the chest is opened, a character can notice that the lid itself is the source of damage simply by looking at it. This is apparent from the elaborate design and sharp bits of metal set in the lid. If the character is curious, a Search check (DC 24) also reveals that the effect is probably explosive. This check is not needed to disarm the trap.

The trap can only be disarmed while the lid is opened. A successful Disable Device check (DC 26) correctly diagnoses the mechanism and disables it. The crucial trigger is a wire leading from the body of the chest to the lid. Careful examination reveals that it is not under tension, and it is fairly clear that it is what releases the final effect. All the rogue need do is cut the wire, although the task is somewhat complicated by the need to hold the lid only slightly ajar. If someone else holds the lid of the chest while he works, the rogue gains a +2 circumstance bonus on the attempt.

While some may regard it as overkill, the trap has the plus side that the items within are relatively safe from the explosion. The most critical components are the spring and the chemicals used. Springs that can hold tension for long periods of time and see a lot of use require sophisticated alchemy and craft to produce. Variations on the damage effect exist, including acid and poison.

Once popular, the Grenade Chest was unfairly criticized for poor design, leading to it falling into disfavor. Cheaper versions suffered from a tendency for the springs to snap due to poor materials used in its construction. Unfortunately, the explosive effect of the trap is triggered by a release of tension in the spring. This resulted in a number of rather unfortunate misfires.

## MAGIC FALLING BLOCK

**Trap Type:** Falling Block  
**Construction Type:** Simple mechanical, magic  
**Activation Type:** Instant  
**Trigger:** Local; magic  
**Mechanism:** Magic, gravity  
**Effect:** Injury, hindrance  
**Attack Bonus:** No attack roll necessary  
**Damage:** 10d6  
**Save:** Reflex save (DC 12) avoids  
**Search DC:** 25  
**Disable Device DC:** 25  
**Challenge Rating:** 7  
**Construction Time/Cost:** 1 week; 6,500 gp; 260 XP

This is a relatively simple trap relying on magic to provide energy and control. It is not hard to detect, with a fairly obvious magic sigil as a trigger, and signs of scraping along the walls providing useful information. If the group risks it, a pebble tossed through the trigger space demonstrates the trap mechanism readily, as a huge stone block falls from the ceiling.

The block itself is not magical. The block is 10 ft. by 10 ft. by 10 ft. The corridor is 10 ft. wide by 9 ft. high. Even when the block has fallen completely, a good foot of it still extends above ceiling level. The spell trigger in the floor produces a continuous but interruptible *reverse gravity*. Anything moving across the floor beneath the block triggers a brief suppression of the spell.

The danger is that anything attempting to pass through this space will be crushed completely. The block weighs tons. Note that if an object in the activation area stops moving, the magic returns and the block falls back upward. However, anything else in the space will also fall upward. This often causes a convulsive series of movements as the spell is repeatedly deactivated.

Luckily, the Reflex save is fairly easy (DC 12), due in part to the noise created when the block begins to fall. In addition, there is a momentary lifting sensation as the character's foot moves into the *reverse gravity* field before the effect goes inactive.

Once identified, the characters still face a problem. The trap is nearly impossible to disarm directly (DC 35). The trigger has a visual component, so characters crossing in *darkness* or under the effects of an *invisibility* or similar spell can cross the area without triggering the trap. In any case, the character must still contend with the *reverse gravity*.

*Dispel magic* cast on the sigil works as normal (13th-level spellcaster as target). However, such a *dispelling* causes the block above to fall, creating a barrier. At this point, a *passwall* or *stoneshape* would be useful. This secondary difficulty was one goal of the design of the trap, to slow down invaders capable of neutralizing it.

Moving at a speed of greater than 150 ft. per round allows a character to simply run through the area before the block can fall. This means that a running character with a speed of at least 40 ft. can make it through, as could a normal character with the Run feat. A character can also make a Tumble check (DC 20) to get through the area, but the consequences for failure are dire indeed.

The magic falling block requires little maintenance, as it is designed so that it lasts long after the builders are gone. It could also be used as an access hall in an arcane guild, as a simple use of *expeditious retreat* would allow all but the tallest of mages easy passage.

The trap can easily be made more deadly. A pit trap placed just beyond the falling block, or underneath it, is a possibility, as is making the falling block invisible. However, sud-

den death traps are unlikely to endear a DM to players. A relatively low-level party with *darkness* or *dispel magic* can potentially neutralize this trap easily.

## PERIVAX'S CHEMICAL CHAOS

**Trap Type:** Chemical Fire Trap  
**Construction Type:** Complex mechanical  
**Activation Type:** Extended  
**Trigger:** Local; switch  
**Mechanism:** Pressure  
**Effect:** Injury  
**Attack Bonus:** No attack roll necessary  
**Damage:** 4d6  
**Save:** Reflex save (DC 22) avoids powder spray  
**Search DC:** 30  
**Disable Device DC:** 30  
**Challenge Rating:** 7  
**Construction Time/Cost:** 7 weeks; 7,000 gp

Perivax's Chemical Chaos is a two-step trap that plays heavily off of two of Perivax's favorite elements in trapmaking: the trapmaker's strong knowledge of alchemy and the exploitation of a character's ignorance of that same science.

Typically placed in an underground cave or stone passageway, this trap's first step is to spray an unsuspecting character with a chemical powder. This happens when a pressure plate on the passage floor is triggered and a high-pressure cone of the powder is sprayed from a small hole placed on one of the passage's walls. A successful Reflex save (DC 22) allows the character to avoid the powder spray.

The dust alone is harmless and produces only a faint brimstone smell. A successful Alchemy check (DC 20) identifies the powder as one of the two major components found in alchemist's fire. Players may assume this to be a malfunctioning trap or a trap that has laid dormant for too long and dried out. A sprayed character cannot remove all of the dust without total submersion in water or through the use of magic, as the fine grains of chemical dust permeate the character's clothing and equipment.

No fewer than 20 ft. down the passageway, an invisible gas fills a 10 ft. area (larger or smaller, depending on the passage). This gas is the second step of this trap as it is the second major component for the chemical reaction.

A character covered in the chemical powder who enters this area suffers 4d6 points of fire damage and is considered to be on fire (DMG 86) as the two chemical agents ignite upon contact. There is no saving throw to avoid being on fire if the character suffers the initial damage. As before, a successful Alchemy check (DC 20) allows a character to smell and identify the gas in the passageway.

An observant rogue, on a successful Search check, most likely notices the pressure plate on the floor of the corridor. Further investigation leads to the discovery of the jet-spray on the wall, adjacent to the floor panel. Near the gas-filled area, a rogue may notice some light scorching or discoloration from previous uses of this trap. A rogue would simply have to jam the floor panel or plug the jet-sprayer to disarm the trap. Of course, on a critical failure, the rogue may accidentally set off the trap with all rules for the trap applying.

## PILLAR OF SHARP AIR

**Trap Type:** Corrosion Pit Trap  
**Construction Type:** Complex mechanical  
**Activation Type:** Extended  
**Trigger:** Local; trapdoor  
**Mechanism:** Gear, counterweight  
**Effect:** Ensnarement, injury  
**Attack Bonus:** No attack roll necessary  
**Damage:** Special  
**Save:** None  
**Search DC:** 25  
**Disable Device DC:** 25  
**Challenge Rating:** 7  
**Construction Time/Cost:** 7 weeks; 7,000 gp

This is an unusual and quite complex mechanical trap that doubles as a polishing or cleaning device. The floor of the room swings down once pressure on the floor increases over a threshold amount and activates the mechanism. A hidden keyhole set just within the room allows the trap to be disarmed. The room is kept free of furniture and other loose items, which may be a tip-off to a seasoned rogue.

Below the floor is a space 40 ft. deep, with a few inches of fine glass dust at the bottom. Once the trap is engaged, vents open and engines start generating huge gusts of air. The wind created forms a vortex within the center of the room, quickly filling with the glass dust. At high velocities glass dust acts like a corro-

sive, wearing away all surfaces. The first round after the trap is triggered, the wind begins to blow. Each round after that, anyone in the pit takes a cumulative 1d6 points of damage. Therefore, the damage on the second round would be 2d6, 3d6 on the third round, and so on. Anyone in the pit also suffers a -2 penalty to all physical skill checks (any check with a physical attribute as its modifier) as he is buffeted by the powerful winds.

The engines run for one minute before shutting down and resetting the floor.

If characters remain alive through the process, they are stuck within the space. The floor above is four inches thick and made of stone, each section supported by two large armatures. The simplest way to escape is to damage the armatures (hardness 10, hp 30), allowing a section of floor to swing open without triggering the mechanism.

The walls of the space are coated by a quarter inch layer of adamantine to prevent wear (hardness 20, 10 hp). An access door is similarly coated and locked from the other side. A rogue may make a Search check (DC 25) to identify the location of the lock mechanism. A series of blows can remove adamantine from the area around the lock, allowing an Open Lock check (DC 20). Trapped characters can also try to break down the door (hardness 8, hp 30, Break DC 28).

There are several clues that a careful observer may pick up. The floor, though stone, bears interesting scratches from the action of the mechanism. The bareness of the room may also be an indication, as are the faint but detectable outlines of the four sections of the floor. Thus alerted, the keyhole can be found in short order (finding the keyhole requires an additional Search check DC 15). Disabling the trap via the keyhole requires a Disable Device check rather than Open Lock. Alternately, the floor can be spiked, but this is a more hazardous course.

This is a rare trap due to the elaborate design. It is mainly used in gnomish and dwarvish settlements where the room is used to create powder from a variety of materials. The resultant powder is sucked into containers and sent through an air tumbling process to separate the glass from the desired materials. Groups capable of producing this trap are also likely to have advanced forges and high-quality machinery.



## QUIET BLANKET

**Trap Type:** Water Pit Trap  
**Construction Type:** Magic, simple mechanical  
**Activation Type:** Instant  
**Trigger:** Local; magic  
**Mechanism:** Magic  
**Effect:** Ensnarement, injury  
**Attack Bonus:** No attack roll necessary  
**Damage:** Drowning  
**Save:** None  
**Search DC:** 28  
**Disable Device DC:** 28  
**Challenge Rating:** 7  
**Construction Time/Cost:** 4 weeks; 5,000 gp; 80 XP

A magical variation on the mundane water pit trap, this is usually part of a more elaborate system. One common form places this spell trap at the bottom of a pit trap. It is also frequently used in a corridor. In either case, anyone stuck in the trap must get out or soon drown. This may involve opening a trap door from below, or breaking down a sealed door. The Open Lock check or Break DC of a door is set at 22. The bottom of the pit or corridor is a metal grate, with water visible underneath.

When a 10 ft. by 10 ft. section of grate is touched, the spell trap casts *control water*. It causes water below the grate to rise up, filling the space. The total volume is 70 ft. by 70 ft. by 14 ft. high, filling the space completely. The effect lasts 70 minutes.

A character entering the area along the side has a chance to notice the trap before activating it. The carefully inscribed symbols and lines in the metal grate are hard to pick out, given the grime that covers them and the poor lighting in the area. Once identified, it requires deft application of the corner of a chisel to cross out a few of the lines and dissipate the magic safely.

## SCREAMING ARMOR

**Trap Type:** Item Trap  
**Construction Type:** Magic  
**Activation Type:** Instant  
**Trigger:** Magic  
**Mechanism:** Magic  
**Effect:** Injury, hindrance  
**Attack Bonus:** No attack roll necessary  
**Damage:** See below

**Save:** None  
**Search DC:** 32  
**Disable Device DC:** 32  
**Challenge Rating:** 7  
**Construction Time/Cost:** 7 days; 350 gp; 14 XP

Many powerful mages and clerics who do not wish to be disturbed favor subtle and nonfatal traps that keep intruders out of their hair. Large traps such as a Screaming Well are not likely to appeal to that set. Necromancers and high priests sitting on skull thrones are the sorts who love the idea of installing a suit of Screaming Armor in the library to entertain unwelcome guests.

The trap is to all appearances a masterwork suit of full plate mail placed in a hall or foyer as a decoration. It has a prominent visor, gilded in gold and platinum, which is elegantly crafted in the stylized shape of a gold dragon's head. It appears to be entirely functional armor and is in all respects a magnificent-looking suit.

The armor tests positive when probed for magical properties, but if someone attempts to manipulate its joints or remove it from its stand, it remains frozen in place. Everything, that is, except the visor. If the visor is raised, it emits a penetrating magical wail that has the effects of a *blasphemy* spell.

A weak magical force holds the armor in place, and a *dispel magic*, *knock*, or similar low-level spell is sufficient to free it. When examined, the armor proves to be finely crafted but ornamental armor. It is trapped, not cursed, and may be donned and removed freely. However, it is hardly a prize. It only provides an armor bonus of +2 due to weaknesses in the joints and materials used in construction, and in all other respects, including maximum Dexterity bonus, armor check penalty and weight, is identical to full plate mail.

Detecting and disarming the trap is extremely difficult because the script that powers the spell is etched on the inner surface of the visor. Detecting the trap entails freeing the armor from its mounting, disassembling it, and peering up into the visor through the neck opening. The script found therein reveals the function of the trap. To disable the trap, a rogue must delicately scratch out the script without opening the visor. Failure sets the trap off.

*Variations:* Substituting other spells for *blasphemy* may create more and less fatal versions of the Screaming Armor trap. *Shatter*, *shout*, *sound burst*, and *wail of the banshee* are all effective alternates. Adjust the trap's CR and construction requirements accordingly (see *Traps and Treachery* page 65). This trap may also be modified to protect a safe, chest, or other closed object.

## STRIP

**Trap Type:** Teleport Trap  
**Construction Type:** Magic  
**Activation Type:** Instant  
**Trigger:** Local; magic  
**Mechanism:** Magic  
**Effect:** Hindrance  
**Attack Bonus:** No attack roll necessary  
**Damage:** None  
**Save:** Will save (DC 17) resists  
**Search DC:** 32  
**Disable Device DC:** 32  
**Challenge Rating:** 7  
**Construction Time/Cost:** 7 days; 3,500 gp; 140 XP

The spell trigger for this trap casts *vanish*, causing one of the items carried by the character to teleport to a secure location elsewhere. There is a 1% chance that the item is simply destroyed. The trap targets the heaviest item carried, so for most characters this means saying goodbye to their armor.

Note that a backpack or other container counts as a separate object. If the backpack weighs more than any of its contents, the backpack vanishes, spilling everything it was holding.

The only way to avoid the trigger is not to touch the 10 ft. by 10 ft. section of floor in which the patterns are contained. The design that makes up the trigger is rather hard to spot, looking much like those of other locations.

This trap is easy to use in well-trafficked areas. Inhabitants merely need to carry a heavy object when moving through the area. This is also a potential way for characters to confound the trap, particularly if they find a storage area with the heavy stones used for this purpose.



## THE DEADLY GROVE

**Trap Type:** Injury and Monster Trap  
**Construction Type:** Complex mechanical  
**Activation Type:** Extended  
**Trigger:** Local; switch  
**Mechanism:** Spring, counterweight, gear (for trapdoors)  
**Effect:** Ensnarement, injury  
**Attack Bonus:** +8 ranged  
**Damage:** 2d6 plus poison  
**Save:** Fortitude save (DC 18) resists poison  
**Search DC:** 30  
**Disable Device DC:** 25  
**Challenge Rating:** 7  
**Construction Time/Cost:** 7 weeks; 7,000 gp

The Deadly Grove is a trap that utilizes a lush grove of beautiful plantlife, poisoned needles, and assassin vines to place characters in a potentially deadly situation.

Placed in deep underground passages or in privately enclosed courtyards, this trap is set within a flourishing grove. The trap is activated when a character breaks a tripwire that is carefully hidden along a path within the



grove. Breaking the tripwire causes all of the exit doorways to automatically lock. A successful Open Locks check (DC 22) is required to open one of these locked doors.

Next, a spring-loaded mechanism fires a hail of needles into the area where the tripwire was broken. The needles have a ranged attack modifier of +8 and are coated with giant wasp poison (DMG 80), which may damage the Dexterity score of a character struck by the needles. Anyone in the area is hit by 1d4 needles.

In addition, 1d6 caged assassin vines are released when the tripwire is broken. These vines are spread about the grove, but there is always one within attack range of the tripwire.

Due to the foliage and overgrowth of the grove, a rogue may have a difficult time spotting the tripwire along the path. If the trap has been activated within two days of the characters' arrival, a successful Alchemy check (DC 28) allows a character to smell the pungent residue of the giant wasp poison, alerting the character to the potential danger. To disarm the trap, a rogue need only avoid the tripwire, or carefully snip and secure the tripwire. On a critical failure, the rogue activates the trap as normal.

Popular variations on this trap include placing secondary traps on the locked doors or placing illusions of false exit doors in the grove to lead characters further into the assassin vines lairs.

## CRYSTAL CASE TRAP

**Trap Type:** Item Trap  
**Construction Type:** Simple mechanical  
**Activation Type:** Instant  
**Trigger:** Local; movement  
**Mechanism:** Pressure, gear  
**Effect:** Identification, injury  
**Attack Bonus:** No attack roll necessary  
**Damage:** Poison  
**Save:** Fortitude save (DC 15) resists  
**Search DC:** 31  
**Disable Device DC:** 26  
**Challenge Rating:** 8  
**Construction Time/Cost:** 8 weeks; 8,000 gp

Collectors often have the desire to put icons of their wealth or other treasures on display for all to see. At the same time, there is a need to keep these items secure. The Crystal Case trap consists of a container made of glass that is

fixed to a pedestal and set against a wall. The cover is intricately chambered, with disks and lines whirled through the material. The sides are much simpler, and the front features an iron lock. From the design, it is clear one can open the lock, then pull off the top to get at the case's contents.

As it turns out, however, this is not the case. The panels of the case are double paned and contain a pressurized vial of numbwrack acid. There is no key for the lock, so it requires a successful Open Lock check (DC 20) to bypass. Once picked, the cover jerks up due to the pressure and the acid sprays out, hitting anybody within 10 feet that fails a Reflex save (DC 15). The pressure loss also activates an alarm, indicating specifically that someone has opened the case.

It is assumed that the person picking the lock can at least jerk aside sufficiently to only get one dose. If for some reason the person is unable to move from in front of the chest, she takes five doses (roll and handle each separately and consecutively) and blocks those behind her from being sprayed.

The proper way to open the chest is actually by carefully unscrewing one of the disks on the cover. The threadwork is difficult to spot, as are the grooves that allow one to insert a fingernail to get the disk turning. The walls of this opening are solid, so no acid is released. The contents of the case can then simply be plucked out through the large hole.

The material itself is hardness 2 (hardened glass), with 1 hp for the exterior and another 1 hp for the interior. That is, 3 hp of damage will only break the outside layer, but 4 hp of damage in a single blow shatters right through. In either case, anyone within 5 feet of the chest gets a dose of acid sprayed in her direction. The attacker, if in range, gets a double dose (make two rolls, consider each dosage separately and consecutively). The chest is AC 5.

However, the lid has no acid within it, a fact that may be apparent with close examination. A character must make a successful attack against AC 10 to hit the lid, and missing by 5 or less results in another part of the case being damaged, probably spraying acid on the offending character.

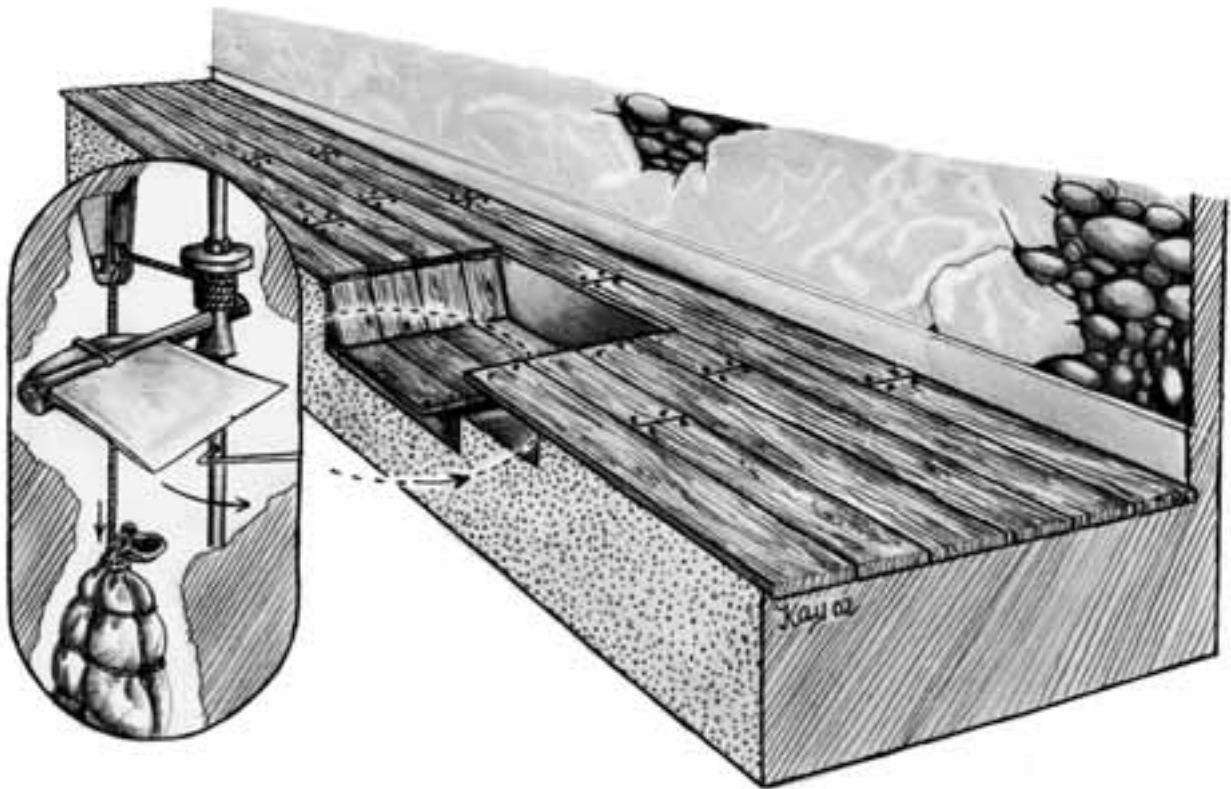

A crystal chest trap is difficult to notice. A thief may detect residue from cleaning, as well as note the holes near the bottom of the case. A character looking specifically at the lid or looking for other ways to get into the chest is entitled to a second Search check. A success reveals the threaded disk in the lid. A successful Disable Device check (DC 25) does likewise, after determining that the lock only functions to release the lid.

This is specifically a one-use trap. The reservoir of acid in the pedestal uses a piston weight to provide pressure. This weight must be lifted, the reservoir filled, and then slowly let down to fill the base of the chest. While the level is even with the top of the chest, the lid is placed back on and locked. The weight is then released to fully pressurize the system. Between the spray of the trap and spillage while resetting it, cleanup is significant. Intruders may happen across cleaning equipment and neutralizing agents elsewhere.

Due to the difficulties of the mechanism's reset, a crystal chest trap requires skilled staff to operate and maintain. It is too elaborate to be maintained by undead, magic, or automated systems. Temples, treasure rooms, or maintained tombs can make good use of the trap. Other poisons that flow well (such as mouth-

eyes poison) can be substituted for the numbrack. The design can also be adapted to doors, windows, and other objects.

## DROP AND SLICE

**Trap Type:** Blade Trap  
**Construction Type:** Complex mechanical  
**Activation Type:** Instant  
**Trigger:** Local; switch, trapdoor  
**Mechanism:** Counterweight, gears, gravity  
**Effect:** Ensnarement, hindrance, injury  
**Attack Bonus:** +15 melee, +15 grapple  
**Damage:** 4d6  
**Save:** None  
**Search DC:** 27  
**Disable Device DC:** 27  
**Challenge Rating:** 8  
**Construction Time/Cost:** 8 weeks; 8,000 gp

Sometimes crippling trespassers is more effective than simply killing them. The Drop and Slice consists of a trapdoor and a blade mechanism. The space below the trapdoor is only a foot and a half deep, so it causes no falling damage. However, the blade swings through this space, ideally hitting the knees or thighs of a target.

This is treated as an attack. If the character is hit, she takes 4d6 points of damage

and is considered lame until the damage is fully healed. In addition, her leg is stuck, pinned by the blade. A successful Escape Artist check (DC 20) is necessary to free her from the mechanism. Characters may aid this action.

It is a little tricky to spot the panel that makes up the trap if the designers have been careful to use the right materials. Still, wear and tear can bring out subtle differences between the panel and the rest of the floor.

The panel is balanced so that a small amount of force keeps it shut. The amount is enough so a cat or a small object can rest on the panel with no effect. If the panel was balanced precisely, floor vibration and other factors could cause the panel to move slightly, betraying its presence.

Stepping on the panel causes it to swing down, also releasing a counterweight in the floor that drives the blade. A spring would allow the blades to fly with more immediate speed, but it is difficult to make springs capable of holding tension for long periods of time. Although the counterweight is not optimal due to its lesser tension, and therefore damaging capability, it is reliable and can be used long term with little or no maintenance.

Popular in conventional security for manses and other buildings, the Drop and Slice provides a deadly protection. Regular patrols augment its usefulness, as snared trespassers have limited time to get free and escape. The trap has to be reset after each use, making it of more limited utility in tombs and other unpopulated settings.

## DROWNING MAIDEN

**Trap Type:** Ensnaring Water Trap  
**Construction Type:** Magic  
**Activation Type:** Extended  
**Trigger:** Magic  
**Mechanism:** Magic  
**Effect:** Ensnarement, injury  
**Attack Bonus:** No attack roll necessary  
**Damage:** Drowning  
**Save:** Will save (DC 19) to resist  
**Search DC:** 33  
**Disable Device DC:** 33  
**Challenge Rating:** 8  
**Construction Time/Cost:** 1 day; 650 gp; 26 XP

The Drowning Maiden is a trap that combines a magic trigger and a sturdy, water-filled statue to punish the curious or greedy.

Typically placed in a hall or mausoleum filled with stone sarcophagi, the Drowning Maiden appears as a 6-foot-tall, ornate stone sarcophagi. The stonework is finely crafted, and is carved to resemble the visage of a beautiful young woman in flowing robes, her face smiling peacefully. This woman is different for every creator, as some use images of past lovers, family members, or perhaps the creator's idea of the perfect female. Many creators place treasures in nearby caskets to lure victims to the Drowning Maiden more easily by exploiting a character's greed.

Any character who touches the maiden must make a successful Will save (DC 19) or be instantly *teleported without error* to the inside of the maiden's casket. Unfortunately for the trapped character, the Drowning Maiden's casket design does not allow it to be opened as would a normal casket.

A character that is *teleported* into the maiden is subject to drowning, as described in the core rules (DMG 85). If the trapped character is able to breathe in water through the use of pre-cast spells, abilities, magic items, etc., she is still trapped within the maiden's casket. The casket is considered to have a hardness of 8, 90 hp, and a break DC of 35. Popular variations on this trap include the use of iron caskets instead of stone, poisons mixed within the water, or caskets filled with other suffocating materials (such as sand or dirt). There are rumors of the mad trapsmith Perivax placing ooze creatures within the maiden's casket.

Due to this trap's magical trigger, it is unusually difficult to notice at a casual glance. Also, because of the nature of the trap, rogues who carefully move closer to the Drowning Maiden to investigate may accidentally fall victim to the trap themselves. A rogue may notice such clues as the maiden's false opening crease, the fact that no visible traces of the casket's ability to open are present, or a slight condensation on parts of the casket. Apart from dispelling the trap's magic, the only method for disarming this trap is to simply avoid it.

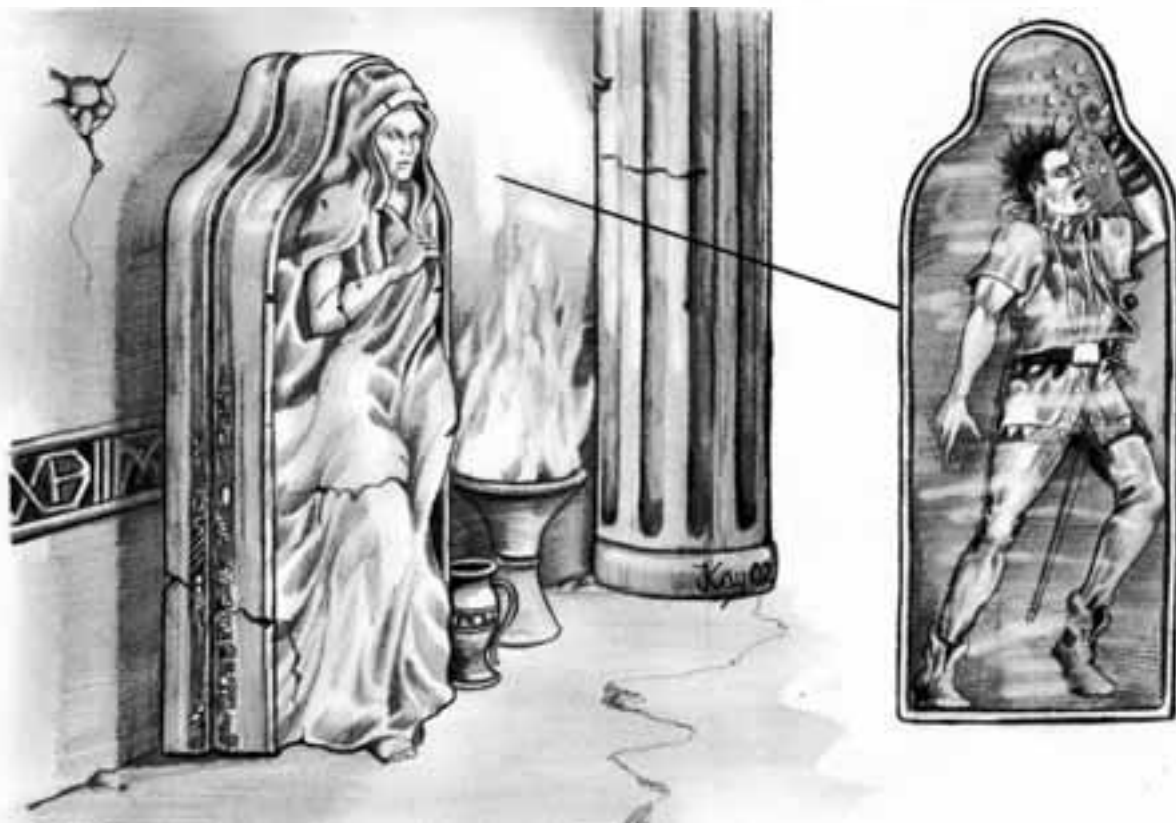

## FALLING WALL

**Trap Type:** Hinged Wall  
**Construction Type:** Complex mechanical  
**Activation Type:** Instant  
**Trigger:** Local; switch  
**Mechanism:** Gravity, spring  
**Effect:** Injury  
**Attack Bonus:** No attack roll necessary  
**Damage:** 8d6 plus fall  
**Save:** Reflex save (DC 24) to avoid  
**Search DC:** 30  
**Disable Device DC:** 26  
**Challenge Rating:** 8  
**Construction Time/Cost:** 8 weeks; 8,000 gp

This trap is usually set at a point where climbing seems necessary. For example, a corridor could end at the base of a vertical shaft, and 60 ft. up another passage is visible. To add to the temptation, a rope or ladder might be seen at the top; all someone has to do is climb up and then lower the rope for the rest of the party. To make matters even simpler, the wall is rough-hewn, with ample footholds and handholds. The climb should be trivial for any moderately skilled rogue.

When the climber begins her ascent, things go quite smoothly for a while. At some point, usu-

ally two-thirds of the way up the wall, the character will hit a trigger point. (There are many of them scattered around the upper third of the wall; any climber will hit one unless she has explicitly taken steps to avoid it. Even then it is difficult, as detailed below.) When a trigger is touched, there is an ominous click, a sudden slight vibration, and then, the surface the character is climbing peels away from the wall, flipping downwards to crush the climber and any of her companions who might be in the way.

The climber must make a Reflex save (DC 24) in order to leap away from the wall; characters on the ground gain a +4 bonus to their save. If the climber successfully leaps away from the wall, she is still airborne and may make a Tumble check as if she had fallen from her current height to attempt to minimize damage. If she fails the Reflex save, she suffers 8d6 points of damage from being crushed as well as for the fall.

This trap is very hard to detect, as the trigger mechanism is far from the ground and well concealed. Possible clues could include odd construction or markings at the base of the wall or a suspiciously high ceiling in front of the wall (allowing the wall to fall forward unimpeded). Odd pits or scratches on the floor from previous triggerings of this

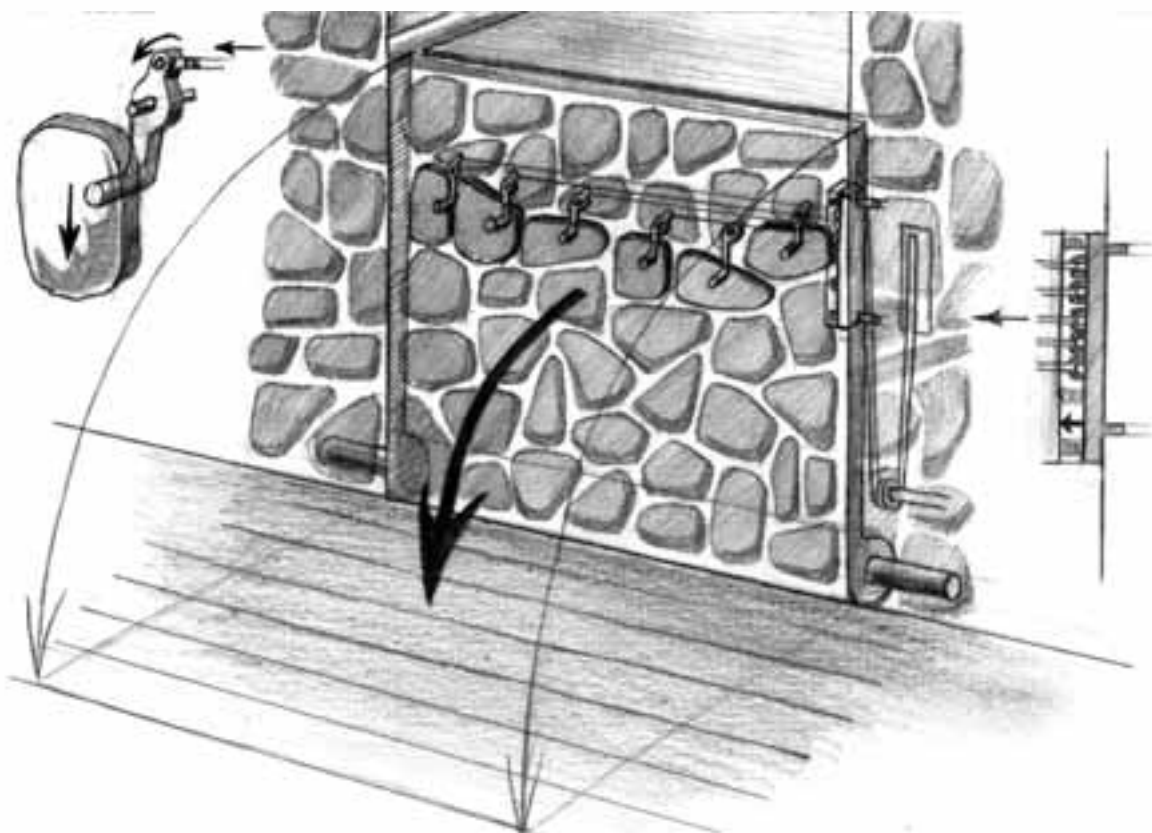

trap might also tip off the truly cautious.

Once the nature of the trap is known, a character may attempt to climb it safely. Doing so requires moving at one-half normal climbing speed, and a Search check (DC 21) must be made each round to avoid accidentally triggering the trap. Alternatively, once the mechanism is known, the characters may attempt to block or jam the hinge at the base; this is not overly difficult, but a failure of any sort during the attempt will bring the wall falling down.

## FRODERICK'S VANISHING LEVITATORS

**Trap Type:** Magical Hindrance Chamber

**Construction Type:** Magic

**Activation Type:** Extended

**Trigger:** Local; magic

**Mechanism:** Magic

**Effect:** Hindrance

**Attack Bonus:** No attack roll necessary

**Damage:** None

**Save:** Will save (see text)

**Search DC:** 20

**Disable Device DC:** 30

**Challenge Rating:** 8

**Construction Time/Cost:** 4 days; 3,600 gp;  
148 XP

This chamber, found originally in one of his many false tombs, is one product of the archmage's questionable mind. Constructed as a large chamber with a high domed ceiling, this trap is a hindrance but is hardly deadly. To attract attention away from the real trap, there is a broad stripe of black painted around the room about eye level for a human. On the stripe are various arcane symbols that have no meaning at all. Down the center of the room on the floor, etched into the molding between the floorstones, is a thin line of faint symbols that triggers the trap when it is crossed. A permanent *nondetection* spell (DC 29 to overcome with divination spells) combined with the sigils' minute size makes searching for the trap very difficult.

When activated, all creatures in the room are hit with a *hold person* spell (Will save DC 19 negates). The next round, any held creatures are targeted by a special *levitate* spell that affects unwilling creatures (Will save DC 19 negates). Those affected by the *levitate* rise 20 ft. toward the dome, the center of which is 30 ft. high, where they are immediately subjected to *invisibility* (Will save DC 18 negates). The result of these two rounds of spell effects could very well be a number of paralyzed trespassers floating invisibly against the ceiling. Treat all spell effects as if cast by an 18th-level wizard.

Disabling the trap is as hard as finding it. The tiny magical sigils must be filled in with some appropriate material, but the rogue doing the work must be sure not to let any part of his person or his tools cross the line while working. Also, missing even a portion of a single sigil leaves the trigger active.

## KALI'S KISS

**Trap Type:** Grab and Impale  
**Construction Type:** Complex mechanical  
**Activation Type:** Instant  
**Trigger:** Local, switch  
**Mechanism:** Spring  
**Effect:** Ensnarement, alarm, injury  
**Attack Bonus:** +10 melee (grapple), +15 melee (spears)  
**Damage:** 8d6  
**Save:** Reflex save (DC 24) to avoid  
**Search DC:** 26  
**Disable Device DC:** 25  
**Challenge Rating:** 8  
**Construction Time/Cost:** 9 weeks; 9,000 gp

This trap is called Kali's Kiss after the goddess whose worshippers first constructed it; the followers of other multi-limbed deities have since embraced the design. Drow, in particular, employ this trap, calling it "Mother's Loving Embrace."

The trap consists of a large statue of a god or goddess (or possibly a monster) whose most obvious distinguishing factor is that it is possessed of a great number of limbs. These limbs will be set back on the statue and usually arranged in a pose of religious significance.

The trap is often set in a chapel, sanctuary, or other room where a large, ornate statue of a multi-limbed deity is not instantly suspect. The lap of the statue is piled high with gems, gold, or other tempting goodies, but they are placed back far enough that they cannot easily be reached without clambering onto the statue. Sometimes, gems or other precious items are set into the chest of the statue, or a valuable necklace is hung around the statue's neck. The key in all cases is to cause a thief to put pressure on the lap area of the statue; when this is done, the trap swings into action.

In temples run by somewhat benign cults, or cults who want live prisoners for some nefarious ritual, the statue acts merely to imprison.

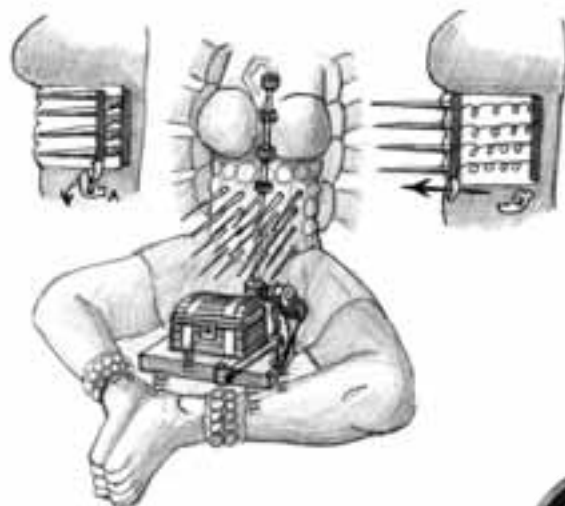
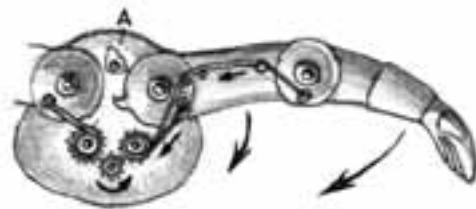

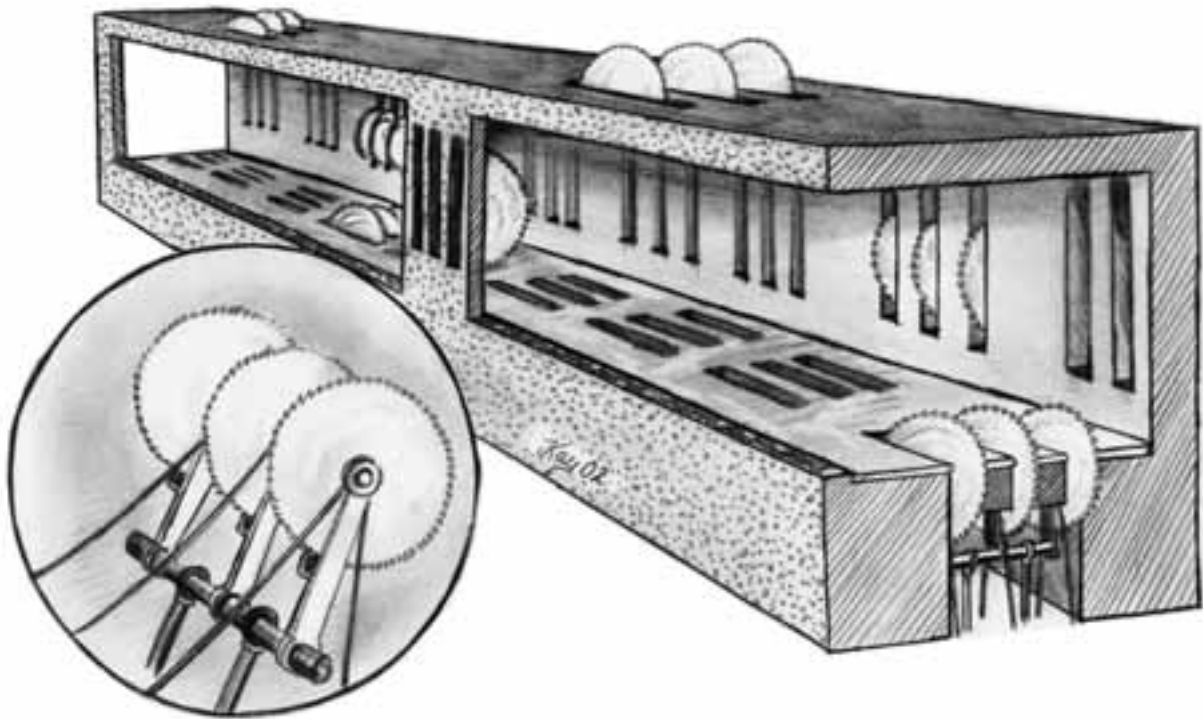

Upon triggering, the arms sweep forward and around, attempting to grab hold of the thief. A Reflex save (DC 24) allows the victim to get out of the way safely. Failing that, the arms grapple the intruder and hold the victim with an effective Strength of 30. The statue counts as a Large creature for purposes of further grapple checks.

In less benevolent cults, a second aspect of the trap activates as soon as the arms are closed. Spears thrust out through the chest of the statue (sometimes up from the base, depending on the design limitations of the statue, but the effect is the same), impaling the held victim. In some rare cases poison is added to the spear tips as an extra deadly precaution.

In addition, the rapid motion of the arms usually sets off a series of bells built into the body, alerting anyone in the vicinity.

Detecting this trap is somewhat difficult. The hingework on the arms is well hidden, and the trigger does not respond to light or gentle prodding; some considerable weight is needed to set it off. Some possible clues include faint traces of dried blood on the base of the statue, or indications of holes where the spears come out. One arm might not be reset properly and a trace of the mechanism could be visible.

The bait is placed so that it is very hard to reach without triggering the trap; any attempt to do so without *mage hand* or similar telekinetic magics likely fails. Disarming the trap usually involves getting behind the statue to damage the mechanism; if the statue is snug against a wall, this might be difficult.

## POWER SAW CORRIDOR

**Trap Type:** Spinning Blades Trap  
**Construction Type:** Complex mechanical, magic  
**Activation Type:** Extended  
**Trigger:** Local; magic  
**Mechanism:** Gravity, gears  
**Effect:** Injury  
**Attack Bonus:** No attack roll necessary  
**Damage:** 8d6  
**Save:** Reflex save (DC 16) avoids  
**Search DC:** 25  
**Disable Device DC:** 31  
**Challenge Rating:** 8  
**Construction Time/Cost:** 9 weeks; 14,500 gp; 260 XP

This trap is a bit tricky to disguise, so it is often set in a long series of corridors with similar, but harmless, grooves cut into the walls and ceiling. Every 10 feet, a set of thin grooves appears on one of the corridor's walls, the ceiling, or

the floor. Four out of five of the sections contain blades that shoot out into the corridor, ripping anything in their path to shreds. The fifth section is a harmless decoy. This pattern is repeated over and over again. Ideally, trespassers will soon lose interest in the pattern before they reach an actual trap.

At the heart of this trap is an engine powered by a *reverse gravity* spell. Variations of this type of engine can be found in a wide variety of traps or devices. The trigger is located in the blank space in the middle of the trap. Once activated, the *reverse gravity* is cast in the chamber immediately below. This has no immediate impact on the characters.

However, a series of weighted wheels are arranged around this chamber. Half within the *reverse gravity* and half outside, they begin spinning with increasing speed. This motion powers a series of circular saws arranged on armatures within the floor, five banks of them in each direction and another set immediately above the center.

As it takes time for the wheels to spin up, power is directed in a pattern. The energy is first transferred to the outer 10-ft. bank of blades on either side. They pop up on the first round, preventing characters from running out of the affected area. On the second round, power is directed to the blades immediately above the center. On the third round and subsequent rounds, blades are sent power from the outside in, one bank on each side activating per round.

By the sixth round, the entire corridor is filled with churning steel, and characters are almost certainly doomed. Note that the save applies if the blades start coming up on a square that is occupied by a character. A failed save indicates that the character takes 8d6 damage per round. After 13 rounds, the spell ends and the blades slow down, withdrawing back into the floor (or ceiling).

There are several ways to escape this trap. The best method is to cast *dispel magic* on the trigger. The spell's caster level is 13, so the DC for the dispel check is 24. This may be cast at any point during the process. Once dispelled, the machinery winds down normally. An *antimagical field* can negate the top portion of the *reverse gravity*, but this only slows down the machin-

ery slightly, granting characters within the field a +4 bonus to their saving throws.

A *stone shape* or other spell that manages to open up the floor in the middle allows up to five characters to escape into the pit below. The characters will be stuck floating at the top of the column of reversed gravity, but will not be touched by the blades above. Once the effect ends, they will drop 60 feet (taking 6d6 points of damage if they do not manage to avoid the fall). Escape is then simply a matter of climbing up and continuing on.

The floor is AC 5, hardness 8, hp 75. It is possible to break through it, but this is quite difficult if the blades have already popped out. In addition, a natural 1 rolled while attempting this requires the usual Reflex save to avoid damage. This is assuming the target is the middle section of floor. The other sections are a good two feet of solid stone (hp 360).

The blades are AC 10, hardness 8, hp 30 each. There are four blades in each section, and each is tilted slightly to make it nearly impossible to wiggle through. The tilt of each section's blades is reversed, from one section to the next. This way anyone managing to crawl through a gap would be crawling into the close-set blades of the next section. Characters on the outer edges of the trap can escape it as normal.

All of the floor blades spin away from the center; the center blades spin in an arbitrary direction. The body of the blade is not a solid piece. It is possible that, with a bit of luck and skill, a piece of metal can be placed into it, causing a jam when the metal is spun into the floor. It is easiest to attempt this maneuver with the blades at the ends.

Sabotaging the machine in this way requires a Disable Device check (DC 21). Success means the blade is blocked and breaks as its gears shear loose. Note that only one blade is taken out by such a maneuver. A failure requires the usual Reflex save to avoid 8d6 points of damage (as the character is yanked toward the spinning blade).

The Power Saw Corridor is formidable, and quite deadly for lone trespassers or those lacking magic. It is designed to kill anyone who traverses the corridor. Inhabited buildings must have alternate routes built in, if the



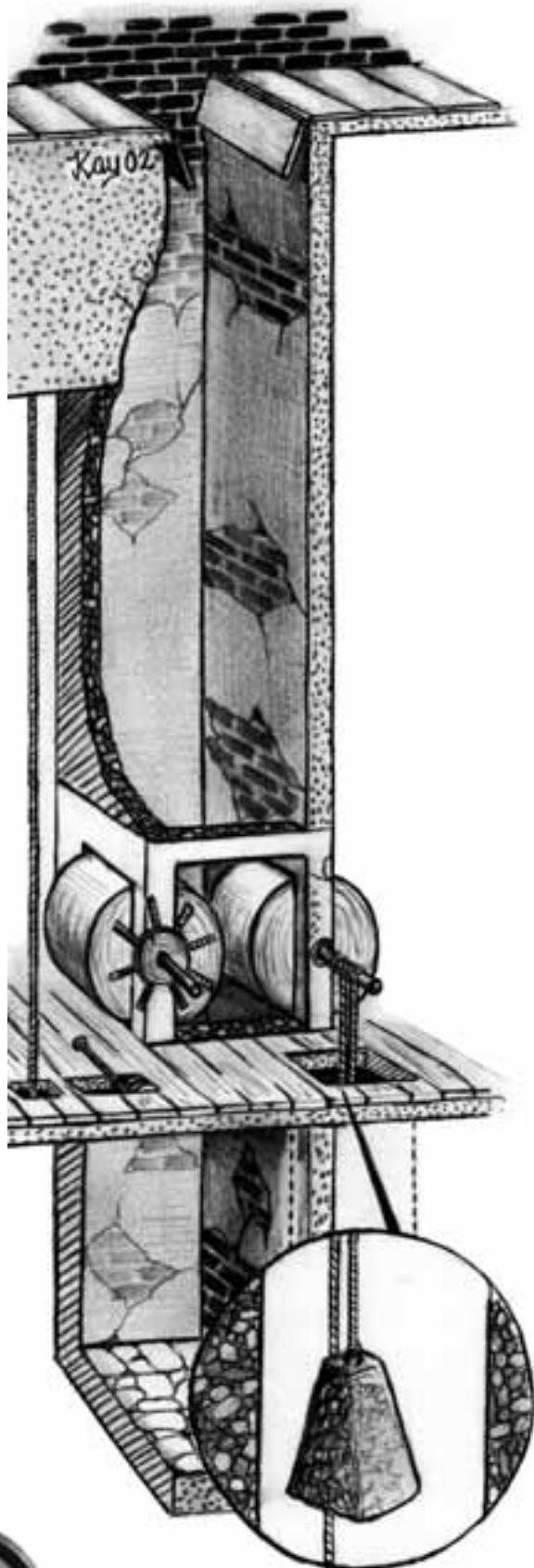

corridor actually goes somewhere important. An alternative is to limit access to characters with an *antimagic field* upon them. There may also be medallions or other trigger keys that prevent the trap from initiating.

The *reverse gravity* removes the need for a reset or external power, though the mechanisms do require periodic maintenance. Enterprising designers may link the engine to other traps, which in turn reset the counterweights and springs.

The engine also demonstrates a mechanism used in some gnomish and dwarvish settlements. *Reverse gravity* can power hammers, conveyers, and other devices. Power is transferred through belts or wires. Particularly large settlements can use alchemically treated bearings and store energy in flywheels. In this way, power can be metered out at a steady rate, with occasional *reverse gravity* refilling these reservoirs of energy. The same system can also be fed from water and steam wheels.

## ROLLER PIT

**Trap Type:** Crushing Roller Trap  
**Construction Type:** Complex mechanical  
**Activation Type:** Instant  
**Trigger:** Local; trapdoor, switch  
**Mechanism:** Gravity, gear, counterweight  
**Effect:** Injury, ensnarement  
**Attack Bonus:** No attack roll necessary  
**Damage:** See text  
**Save:** Reflex save (DC 20) avoids  
**Search DC:** 24  
**Disable Device DC:** 30  
**Challenge Rating:** 8  
**Construction Time/Cost:** 8 weeks; 8,000 gp

The roller pit uses a bi-fold trapdoor as a trigger to release counterweights on a pair of cylindrical stone rollers built into the walls of a 10-ft. square pit. Any unlucky creature falling into the pit is likely to be forced through the narrow gap between the slowly rotating cylinders.

This deadly and expensive trap is built in high security areas such as treasuries and noble safe houses where security personnel can maintain it. Creatures failing their Reflex save (DC 20) are dropped 40 feet through the trapdoors onto the stone cylinders (4d6 points of damage). The opposing cylinders are set horizontally into the walls where they rotate slowly inward toward a

four-inch gap that separates them. A creature must make a Reflex save (DC 24) each round or be pulled into, and possibly through, the narrow gap. The damage from the rollers is based on the height or length of the creature being crushed, whichever dimension is greatest. The cylinders rotate creatures through at a rate of three feet per round and cause 2d6 points of damage for each foot of a creature's height or length, rounded up. Thus, a 6' 4" tall man would suffer 6d6 points of crushing damage each round for two rounds and 2d6 points in the third round as he was forced through the rollers.

Creatures caught in the rollers can make a Strength or Disable Device check (DC 30) to stop the rollers each round. The cylinders rotate for 1d6+6 rounds before losing momentum. Creatures that are forced through the rollers drop an additional 20 feet (2d6 points of damage) into a chamber where they can be taken into custody by security patrols. An adjacent chamber houses a mechanism that allows the counter-weight to be reset and requires three full rounds and a Strength check (DC 18) to winch the weights back into place.

The CR listed for this trap is only awarded if

one or more creatures fall into the pit. Experience for encountering the pit without falling through to the rollers should be rewarded as if it were a 60-ft. deep pit (CR 3).

A clever rogue will notice the trapdoor with a successful Search check and can wedge the hatch shut in a similar manner to any other pit. Disabling the rollers requires a bit more skill (Disable Device check DC 30) to jam or wedge in place.

## THE ACIDIC PATH

**Trap Type:** Acid Pit Trap  
**Construction Type:** Simple mechanical  
**Activation Type:** Instant  
**Trigger:** Local; trapdoors  
**Mechanism:** Gravity; pressure  
**Effect:** Ensnarement; injury  
**Attack Bonus:** No attack roll necessary  
**Damage:** Acid  
**Save:** Reflex save (DC 15) avoids  
**Search DC:** 21  
**Disable Device DC:** 24  
**Challenge Rating:** 8  
**Construction Time/Cost:** 8 weeks; 10,000 gp

The Acidic Path is a simple trap that uses a

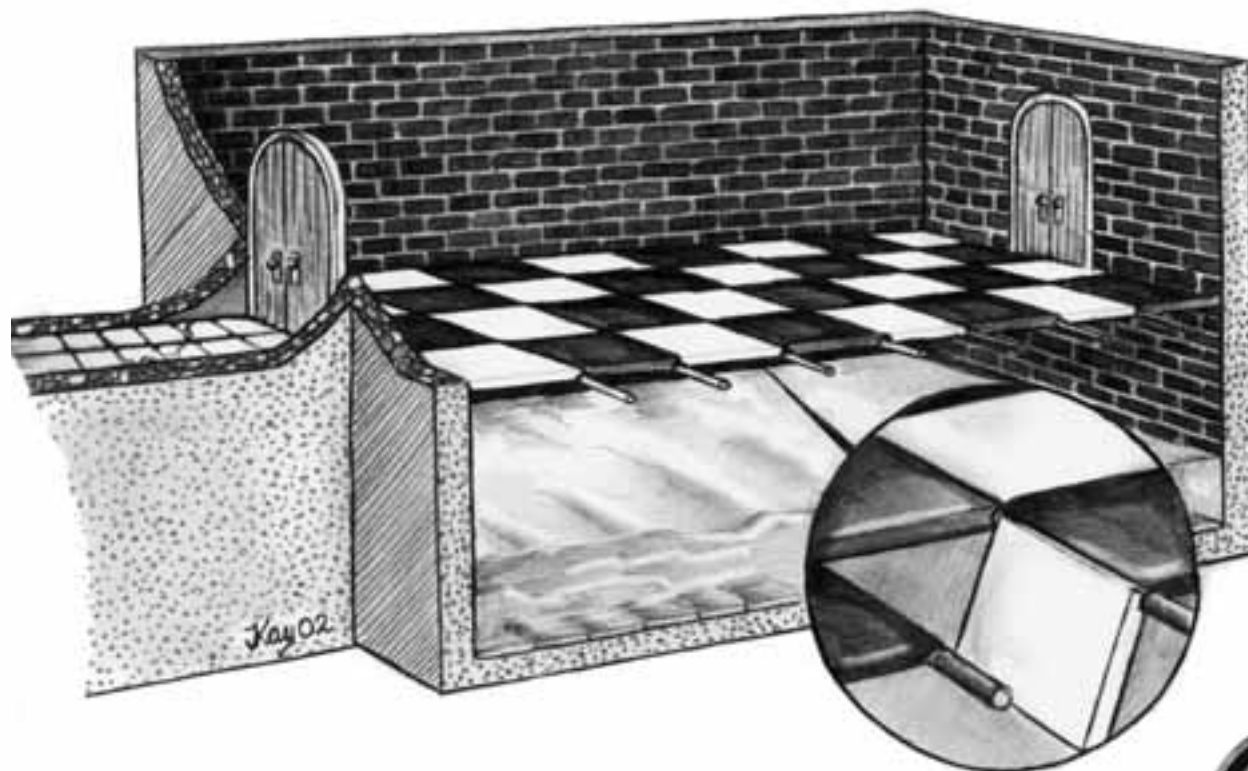

series of trapdoors and a long pool of acid to punish slow-footed characters.

Primarily placed in a dungeon complex or a large stronghold, this trap appears to be nothing more than a normal hallway to the naked eye. The floor of the hall is always constructed from a study stone and always bears a checkerboard pattern. This allows henchmen and other servants to safely learn the true path and avoid activating the trap.

If a character steps onto one of the trapped floor tiles, the tile will act as a trapdoor and immediately collapse, dropping the character 20 feet into a pool of acid that is 6 feet deep and is the exact size and shape of the hallway above. A successful Reflex save (DC 15) allows a character to avoid the trapdoor, but in doing so she must move off of the trapped floor tile. When she does this, she may step onto another trapped tile and must make another successful Reflex save at a -1 penalty for every consecutive Reflex saving throw she makes as she jumps quickly from one tile to the next.

To prevent characters from taking their time in the hallway searching for the safe squares, the designer placed an auxiliary mechanism into the trap's design. While many of the tiles open upon contact, all of the tiles in the hallway are trapped. If more than 20 lb. rests on an individual square for more than 1 round after the first trapped tile is triggered, the tile falls into the acid, thus forcing a character on the square to make a successful Reflex save or fall into the acid.

While trapped within the acid, a character suffers from acid exposure damage for each round she remains trapped within. See the core rules (DMG 88) for full details on acid damage and the effects of acid immersion. Any spellcasters trapped within the acid who attempt to cast a spell must make a successful Concentration check (DC 15 + damage taken in the round) or be unable to cast spells of any kind.

Characters who survive the initial acid damage may attempt to climb out of the acid pool; a successful Climb check (DC 20) is needed to scale the smooth stone surface.

An observant rogue, on a successful Search check, may notice the slightly larger grooves between the trapped floor tiles or possibly smell the scent of the acid from the pool below.

## THE AVALANCHE

**Trap Type:** Falling Boulder Pit Trap  
**Construction Type:** Simple mechanical  
**Activation Type:** Extended  
**Trigger:** Local; tripwire, switch  
**Mechanism:** Gravity  
**Effect:** Ensnarement, injury  
**Attack Bonus:** No attack roll necessary  
**Damage:** 8d6 (rocks) and 4d6 (fall)  
**Save:** Reflex save (DC 20) avoids  
**Search DC:** 26  
**Disable Device DC:** 31  
**Challenge Rating:** 8  
**Construction Time/Cost:** 9 weeks; 9,000 gp

The Avalanche is a trap that consists of two steps; a series of falling rocks followed by the tripping of a pit trap in an attempt to bury trespassers alive.

This trap is always placed within a large stronghold or dungeon complex. The amount of necessary space and materials required for this trap's construction demands that the area be larger than that found within an average stronghold or complex.

This trap is activated when a character breaks a simple tripwire mechanism placed across a stone passageway. When the tripwire is broken, a series of simple yet sturdy latches activates to release the trapdoor chutes that are placed parallel on each side of the tripwire. With the chutes opened, two sets of large rocks are released filling a 10-ft. area around the tripwire.

The falling rocks follow the rules for landslides in the core rulebooks (DMG 85), including the presence of two danger zones. The first is the bury zone, which is the area 5 feet from the tripwire itself. A character in this area must make a successful Reflex save (DC 20) or suffer 8d6 points of damage and be considered pinned. A pinned character must make a successful Strength check (DC 22) or Escape Artist check (DC 22) to escape from the rocks. The second area is the slide zone, which is the area located 10 feet from the tripwire. A character in this area must make a successful Reflex save (DC 15) or suffer 3d6 points of damage.

The second step of this trap is the weight sensitive, 10-ft.-wide trapdoor that is placed under the tripwire area (which is 10 ft. wide itself). The trapdoor runs the full width of the passage,

as there is no ledge or recess on which a character can cling. Characters pinned within the bury zone receive no saving throw to avoid the 20-ft.-deep pitfall, while characters within the slide zone must make a successful Reflex save (DC 15) or fall into the pit as well. Characters that fall into the pit with the fallen rocks suffer an additional 4d6 points of damage (2d6 for the fall and 2d6 for the falling rocks). As before, pinned characters must make the necessary checks to free themselves.

An observant rogue may notice the tripwire in the passage or hear the faint sounds of the occasional shifting rock within the chutes. The chutes are 10 ft. wide and are placed towards the upper side of the walls, closer to the ceiling. By doing so, the difficulty to detect this trap is increased as well as making the trap more deadly.

## THE STICKY SLAP

**Trap Type:** Catapult Trap  
**Construction Type:** Complex mechanical  
**Activation Type:** Instant  
**Trigger:** Local; switch  
**Mechanism:** Spring  
**Effect:** Ensnarement, injury  
**Attack Bonus:** No attack roll necessary  
**Damage:** 4d6  
**Save:** Reflex save (DC 25) avoids  
**Search DC:** 27  
**Disable Device DC:** 27  
**Challenge Rating:** 8  
**Construction Time/Cost:** 8 weeks; 56,200 gp

For those with deep pockets, few traps are as nasty or utterly binding as the Sticky Slap. Due to its eccentric nature and immense expense, this trap is extremely rare, if not unique. Institutions such as governments and military organizations favor more cost-effective defenses, while the Sticky Slap is the sort of trap more appealing to a wealthy, high-powered individual who expects to use it infrequently at best.

The Sticky Slap consists of two primary components: the launch pad and the ceiling-mounted glue disks. The launch pad is a 10 ft. by 10 ft. wooden platform which in all respects matches the surrounding flooring (this trap is for obvious reasons typically placed in a corridor or room with wooden floors). This platform is actually the business end of a vertical catapult array concealed beneath the floor. When

the platform is trod upon an internal pressure plate is triggered, and the catapult hurls the platform up at great speed until it hits the stone ceiling. Those on the platform take damage when they hit the ceiling, but their fun is just beginning.

Mounted on the ceiling where the platform strikes are 16 delicate glass vials, typically painted to match the rest of the ceiling. Each vial is four inches in diameter and a quarter inch thick, and each is filled with *sovereign glue*. Less expensive versions of the trap use tanglefoot bags, even though these provide a much shorter duration. These vials provide coverage to the entire area impacted by the platform. The vials shatter when struck, spilling their contents on everyone and everything pinned to the platform. The platform continues to pin its victims to the ceiling until cranked back down, which requires access to the winch room on the level or floor immediately below (where the catapult machinery is located).

Victims making a successful Escape Artist check (DC 25) manage to writhe out of the trap, drop to the floor and strip their soaked armor and clothes off before the glue sets. Less fortunate victims find themselves glued to whatever they are wearing, the ceiling, and the platform.

Until liberal doses of *universal solvent* are applied, the platform cannot be lowered without ripping the skin off its victims. (The owners of this fiendish trap seldom apply the solvent before lowering the platform, to the dismay of those caught in it.) Fortunately, a supply of the rare *universal solvent* is almost always secreted somewhere around a Sticky Slap trap (usually in a guardroom or with the winch).

Detecting the trap is rather difficult due to its expensive components; special care is made in concealing its presence from trespassers. The vials on the ceiling are the closest things to a tip-off, but their significance is often veiled by the presence of look-alike disks on the rest of the ceiling, made to look like decorations.

Disarming the trap is difficult as well—avoiding the platform or setting it off remotely are the easiest ways to disable it. The winch room below gives ready access to the cat-

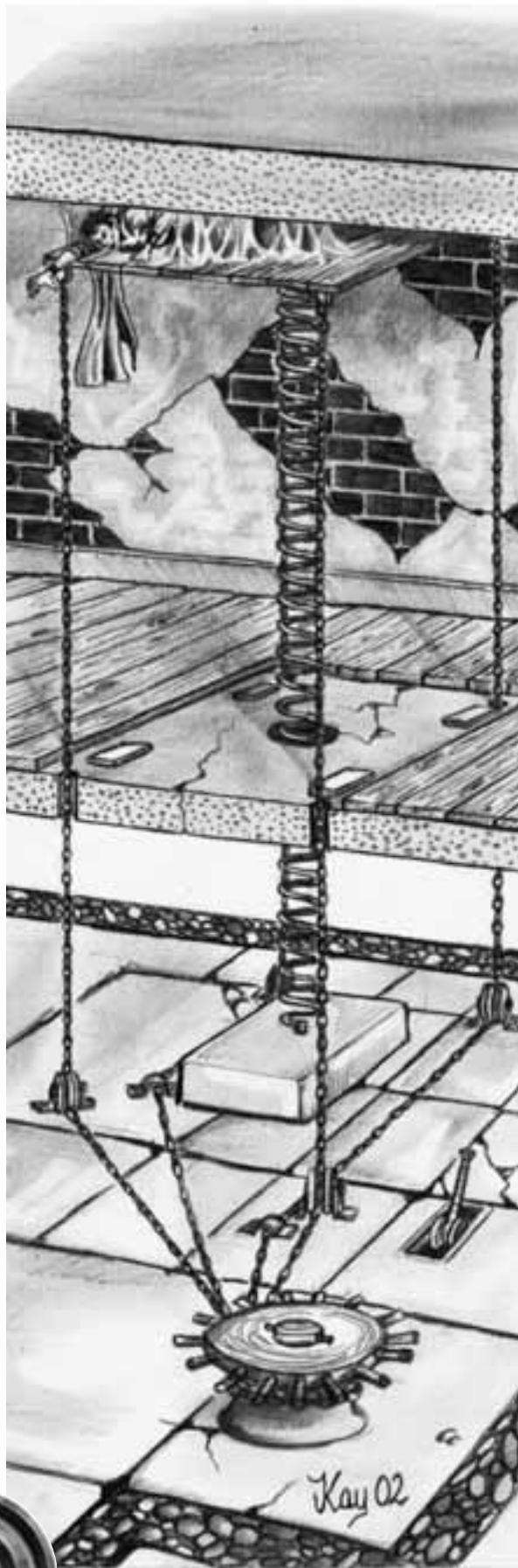

apult mechanism and the pressure plate, but this room is seldom accessible to those who have not yet encountered the trap.

Setting off the trap seldom ruptures all of the vials. 1d4 intact vials may be recovered by applying *universal solvent* to their upper regions. Each vial contains three ounces of *sovereign glue* and an ounce of *oil of slipperiness*.

## WARDÉD REPOSE

**Trap Type:** Imprisonment Trap  
**Construction Type:** Magic  
**Activation Type:** Instant  
**Trigger:** Local; magic  
**Mechanism:** Magic  
**Effect:** Ensnarement, hindrance  
**Attack Bonus:** No attack roll necessary  
**Damage:** None  
**Save:** Will save (DC 17) negates (see below)  
**Search DC:** 33  
**Disable Device DC:** 33  
**Challenge Rating:** 8  
**Construction Time/Cost:** 9 days; 9,000 gp; 160 XP

The version of Warded Repose presented here is a potent trap, meant for those clever enough to evade other less significant (and cheaper) traps. A common one-use variation can be smuggled into the room of important people, where the trap is likely to spring on the desired target.

Warded repose casts *binding* when triggered, in the form of bound slumber. The trigger is based on touch. If the target fails a Will save she is placed in a comatose sleep for 15 months. In addition, the character is bound by restraints that generate *antipathy* against anyone who approaches. Uttering a code word and pointing to the bound character dismisses the binding, though such words are usually jealously guarded by the trapmaker.

The trap works against any beings of up to 9 HD, whether creatures or people. If below 7 HD, the target does not get a saving throw. A Warded Repose trap normally has 50 charges.

The delicate filigree that makes up the physical shape of the trap is easy to miss, but it is unmistakable once spotted. Fine wires of silver and gold are embedded into the floor, dotted with tiny shards of opal. Prying up specific juncture sigils disarms the spell.

## AVERT THE UNWANTED HAND

**Trap Type:** Avoidance Trap  
**Construction Type:** Magic  
**Activation Type:** Instant  
**Trigger:** Local; magic  
**Mechanism:** Magic  
**Effect:** Hindrance  
**Attack Bonus:** No attack roll necessary  
**Damage:** None  
**Save:** Will save (DC 18) partial  
**Search DC:** 34  
**Disable Device DC:** 34  
**Challenge Rating:** 9  
**Construction Time/Cost:** 5 days; 4,500 gp; 180 XP

A potent guard against theft, this trap is also a good way to prevent intruders from using certain doors or operating switches. It compels a character to go away, but otherwise poses no direct danger. The trap is often used by wizards' guilds to protect valuable libraries. It is also found protecting the holy sites of powerful druids.

The trap casts *antipathy* upon either the area or object it is on. The design of this spell trap allows some leeway as to what type of creature is averted. A range of possible targets can be set up, whether by alignment or race. When one of those types triggers the trap, the *antipathy* is cast against it. The spell lasts 30 hours, and will not be triggered again by the targeted creature type while the duration continues. However, the creator can set the trap up to be triggered by multiple creature types. It could trigger first for humans, then hobgoblins, and then halflings. Each effect is considered separately.

The trap can detect alignment. Like race, it can potentially trigger on multiple alignments. For racial types, it relies on darkvision to determine appropriate appearance. It is not intelligent, so even an average Disguise skill check will fool it. An invisible character does not activate the trap, regardless of the trigger used.

The targets are chosen based on why the trap was set up. Druids may specify alignments or a range of unfriendly races. Wizards set up wards against most of the major races, particularly humans, halflings, and half-elves, the races most likely to be rogues. The biggest drawback to this expensive spell trap is that it can trigger multiple times, quickly running through its 50 charges. It is best placed beyond other traps, so

its power is rarely needed.

This trap is likely to be featured in stories about an area or item. Tales of characters running from dark groves or arcane labyrinths can provide a clue. A scholar or mage can provide an idea of what spells might be involved, provided he has heard the stories. In any case, the tracteries of lines and spots that make up this spell are quite difficult to make out. The trap is a substantial challenge for even the most resourceful rogues. A drop of molten lead and some careful chisel work can, if applied just right, disable it.

## HAND IT OVER

**Trap Type:** Item Trap  
**Construction Type:** Magic  
**Activation Type:** Instant  
**Trigger:** Local; magic  
**Mechanism:** Magic  
**Effect:** Hindrance  
**Attack Bonus:** No attack roll necessary  
**Damage:** None  
**Save:** None  
**Search DC:** 34  
**Disable Device DC:** 34  
**Challenge Rating:** 9  
**Construction Time/Cost:** 5 days; 4,500 gp; 180 XP

A nasty little item curse, this trap has been used on a number of holy relics and artifacts. A skilled mage may be able to remove the curse, assuming she is not affected by it. It will take some skilled work to function around the trap's effects, or endurance to last through all 50 charges. The nature of the trap's magic functions much like truly cursed items, making it difficult for a character to get rid of the item. The way it achieves this, however, is rather convoluted.

The trap has a complex trigger that relies on a form of *sympathy*. It can tailor this effect to specific targets. When in someone's possession, either held or within 10 feet, it will seek out a powerful character within view of the possessor. It is not always accurate in these estimations, but once a creature or person of roughly 9 HD or more is sensed, it locks onto that creature's racial type and activates.

The effect is to cause complete chaos. A possessor of the item guards it jealously,

while potentially lethal opponents feel the overwhelming desire to steal it away. Each triggered effect lasts up to 34 hours, and there are 50 charges.

The trigger is somewhat clever, and has a limited form of telepathy. It activates whenever the possessor of the object attempts to get rid of it. The trap does not target friends and direct associates of the possessor, unless it detects clear signs of animosity. If there are suspicions voiced around it, it may go quiet for days or weeks at a time. It may bide its time if the possessor is preparing to appear before a king or other powerful character, and tries to make sure it is brought along.

The spell trap may have a specific type or alignment that it will regard as safe. When the item is in the possession of a proper owner, it remains quiet.

This trap is typically worked into a magical artifact. It is difficult to even notice that magic is at play, since the desire to keep or procure the item is fairly normal. Over time, however, characters involved may slowly realize that events are not normal.

The subtle nature of the trap, and its presence on a magical item, is unlikely to draw attention. Once alerted, it is still quite hard to pick out the magical symbols and patterns of the trap from those of the item itself. An infusion of amber, mercury, and delicate tapping with a silver pick is necessary to disable the trap. Destroying or disenchanting the item successfully destroys the trap as well. These attempts are complicated by the magic of the trap itself, however.

## TOMB OF ICE

**Trap Type:** Freezing Water Trap

**Construction Type:** Simple mechanical, magic

**Activation Type:** Extended

**Trigger:** Local; trapdoor, magic

**Mechanism:** Gravity, magic

**Effect:** Ensnarement, injury

**Attack Bonus:** No attack roll necessary

**Damage:** 9d6 plus 1d6 subdual per round

**Save:** Reflex save (DC 22) partial

**Search DC:** 30

**Disable Device DC:** 30

**Challenge Rating:** 9

**Construction Time/Cost:** 1 day; 450 gp; 18 XP.

The Tomb of Ice is a trap used to torture slow-footed adventurers who find themselves in areas where they should not tread. By using a well-hidden pit of water and a series of spells, this trap freezes its victims before they can muster a scream for help.

In almost every case, this trap is designed for outdoor use, found within arctic or snow covered regions, and usually in or around the builder's lair. In some cases the builder modifies this trap for placement within strongholds or dungeon complexes, but these occurrences are rare. It is designed as a deterrent for trespassers or unwanted visitors and it is used for one purpose: to kill.

For outdoor use this trap is activated when a character steps across the snow-covered trapdoor that conceals an icy, 30-ft.-deep chute. A successful Reflex save (DC 26) is required to avoid falling into the well-hidden chute. A character that falls into the chute sustains no damage as the chute is angled; this also means, however, that characters may not react until they have reached the bottom of the chute. The trapdoor automatically resets after two rounds. A successful Strength check (DC 20) holds the trapdoors open. Additionally, attempting to climb the chute is extremely difficult and requires a successful Climb check (DC 30) to move at one-quarter speed. Characters who fail this Climb check fall down the chute (this is a one use-trap; if it has already been activated, then characters need only worry about climbing out before they freeze to death).

Once a character reaches the bottom of the chute, she is dropped 10 feet into a 10 ft.-deep shaft of icy water. When a character falls into this water, the second step of the trap is activated. A motion sensitive magic trigger placed along the edge of the chute activates a *cone of cold* spell that is stored in an emerald at the bottom of the shaft. A character in the water must make a successful Reflex save (DC 22) or suffer 9d6 points of cold damage, taking only half damage on a successful save. The spell flash freezes half of the water in the shaft and reduces the trapped characters to an accelerated state of below zero conditions (DMG 86).

With that, a trapped character must make a Fortitude save (DC 15 + 1 for every previous check) each round for as long as she is in the water. A character that fails this save is consid-

ered to be fatigued (DMG 84) as well as suffering normal damage. To pull an encased character free requires a successful Strength check (DC 20). A trapped character may not free herself, but may aid any attempts to do so.

Even a keen-eyed rogue may notice only a few signs of foul play when searching for this trap. One such sign may be indications that the trapdoor has recently been activated, such as the snow around the top of the trapdoor being deeper than the snow on the trapdoor itself. Beyond this, detecting the trapdoor above the chute is very difficult.

To disarm the trap, a rogue need only use a successful Disable Device check to jam a climbing piton or similar object into the trapdoor to prevent it from opening. Naturally, with a failure of 5 or more (or a critical failure) the trap is triggered and proceeds as normal. A successful Reflex save (DC 21) is necessary for the rogue to avoid falling into the icy chute.

## CUTFOOT BRIDGE

**Trap Type:** Bladed Bridge Trap  
**Construction Type:** Complex mechanical  
**Activation Type:** Instant  
**Trigger:** Local; switch  
**Mechanism:** Counterweight, gears  
**Effect:** Ensnarement, injury, movement  
**Attack Bonus:** No attack roll necessary  
**Damage:** 8d6 (bridge); 4d6 (pit)  
**Save:** Reflex save (DC 22) avoids  
**Search DC:** 27  
**Disable Device DC:** 27  
**Challenge Rating:** 10  
**Construction Time/Cost:** 10 weeks; 10,000 gp

A nasty little number, the Cutfoot Bridge is designed for catwalks and bridges underground or in other large spaces. The bridge is built of a number of horizontal bands, one of which is actually a pressure plate. This switch releases the mechanism, and there is usually a lock elsewhere to prevent the trap from firing if authorized persons are using the bridge. The crevasse underneath the bridge is 40 feet deep.

The device attacks with a long blade that spans the width of the bridge. It is set on two arms that insert into grooves on the bridge's sides. The arms within the grooves are attached to cables. This structure rests within a space in one of the two side walls of the cavern. When

the mechanism is activated, a counterweight pulls the cables, sending the blade rushing at great speed along the bridge. The edge of the blade is five inches above the surface, perfect for striking the shins or ankles of anyone on the bridge.

Potential targets must make a Reflex save (DC 22), allowing the character to jump over the oncoming blade. If he fails the save, the character takes 8d6 points of damage and is considered lame (see page 69 for details). The character must also make another Reflex save (DC 22) to avoid falling off the bridge and taking an additional 4d6 points of falling damage. Climbing out of the pit is fairly easy.

Once on the opposite side, the blade is locked into another concealed space. The trigger, when released, causes it to be pulled back in the opposite direction (the blade is double sided). This continues until the counterweight is completely spooled out (after six uses).

The design of the bridge makes the trap hard to spot, but a number of factors may raise suspicions. The banded design is odd. The large step down (to accommodate the secreted blade mechanism) is also somewhat unusual. Ultimately, the pressure plate, as well as the slight differences in how it wears from the materials around it, is the biggest clue an observant character can notice to give away the trap.

Disabling the switch is the easiest way to disarm the trap. The speed of the blade makes breaking it (by planting a steel rod, for example) unlikely. The blade deals full damage to the object first. If the object is still intact, the blade has been stopped. Anyone holding an intervening object must make a Strength check (DC 25) to avoid being knocked off the bridge (add +4 to the check if the character is braced for impact). If the object being held is destroyed by the impact, the blade carries through and deals full damage to the character that was holding it.

This device can also be set into corridors, though without the falling chance (reducing the CR by 1). It requires some maintenance, but is a fairly robust design. Combined with a situation that requires running or other pressing concerns, the trap can give even powerful characters a great deal of trouble.



## ILLUSORY OUBLIETTE

**Trap Type:** Pit and Force Wall  
**Construction Type:** Magic  
**Activation Type:** Instant  
**Trigger:** Local, magic  
**Mechanism:** Gravity  
**Effect:** Injury, ensnarement  
**Attack Bonus:** No attack roll necessary  
**Damage:** 2d6  
**Save:** Reflex save (DC 23) avoids  
**Search DC:** 30  
**Disable Device DC:** 30  
**Challenge Rating:** 10  
**Construction Time/Cost:** 5 weeks; 7,000 gp; 200 XP

Pits are wonderful traps, or so they seem to the narrow mind. Easy to build, and requiring little maintenance, countless temples, castles, and lost tombs are liberally supplied with them. There is one major problem with pits, though; people tend to climb out. Those who raid tombs tend to come equipped with spikes, rope, poles, and several healing potions, and any pit not instantly fatal tends to be only a minor annoyance. Magic changes the basic equations of trapmaking, but magic can always be countered by magic.

The Illusory Oubliette is usually placed in a larger room, as it is most effective when it can grab an entire party. It consists of a large pit, usually circular, that is covered by a *wall of force*. The pit is in turn covered by a *silent image*, the image being that of a normal stone or wooden floor. When someone passes a predetermined point (usually the center of the room), the *wall of force* is momentarily turned off, and those standing on it plunge downwards into the fairly shallow pit. An instant later, the *wall of force* reactivates.

Those in the pit are now locked below a field of energy that cannot be dispelled. There is no light in the pit; the *silent image* blocks any coming from above. Non-magical light, such as that from torches, simply consumes oxygen very quickly. (There is enough air in the pit for one man for eight hours.) The walls are solid and smooth, and climbing does little good anyway, as the ceiling of the pit is effectively impervious. Even if the issue of air is solved, there is the problem of food and water.

There is a brief moment after the pit has

opened, and before the *wall of force* over the ceiling reactivates, when someone could leap out. This requires a successful standing high Jump check (DC 25). The DM should allow such a leaper to land outside the pit area, though if they are foolish enough to walk across the trigger zone again, they will, of course, fall back into the pit.

This trap's danger is truly recognized when it traps an entire party. The DM should be prepared to have some way out if the party lacks the means to escape from the pit. The one upside to this trap is that prior victims may well have left behind a lot of weapons, armor, treasure, etc. It might even be that an item needed to proceed further into the complex is lying at the bottom of the oubliette, in the possession of some luckless former adventurer who got this far, but no further.

Detecting the oubliette can be accomplished by noticing the odd sounds made when the *silent image* covering the *wall of force* is crossed, or by sensing the magical energies in the room. It is also possible that the ghost of a prior victim may warn the party; or it may vengefully lead them onwards, so that others may share its miserable fate.

## NO EXIT

**Trap Type:** False Stairway Trap  
**Construction Type:** Simple mechanical  
**Activation Type:** Instant  
**Trigger:** Local; switch  
**Mechanism:** Gravity  
**Effect:** Injury, ensnarement  
**Attack Bonus:** No attack roll necessary  
**Damage:** 10d6  
**Save:** Reflex save (DC 20) avoids  
**Search DC:** 25  
**Disable Device DC:** 25  
**Challenge Rating:** 10  
**Construction Time/Cost:** 10 weeks; 10,000 gp

This trap is a classic design intended to entrap a party of adventurers in an escape-proof false stairway where they can be left to die of starvation or be dealt with at a later time by the denizens of the dungeon.

At first glance, the trap is simply a typical stairwell that appears to lead to the next lower level of a dungeon, temple, or other underground

facility. The only difference immediately noticeable is that the stairwell seems longer than normal—40 feet is typical—and that there is a door at the far end of the stairs.

The stairwell is longer in order to induce the entire party onto the stairway while they move ahead to examine the door for traps. The door is actually false, with a cleverly designed trigger that can only be sprung by opening the door itself. This trigger is nearly impossible to detect since it is actually on the far side of the door, attached to the wall. The only way to avoid this particular trap is to not open the door at all.

Once the trap is triggered, a 10-ft.-wide stone block falls into the corridor at the top of the stairs, trapping the party in the stairwell. Anyone remaining in the corridor at the top of the stairs is crushed beneath the stone block, taking 10d6 points of damage. An alternate to this trap, designed to be more immediately fatal, has the stone block dropped onto the staircase itself. In this case the block slides quickly down the stairs, smashing into the false door at the bottom and crushing the intruders.

Normally nothing but several feet of stone lies behind the false door, but DMs may place whatever they like behind it. Rooms full of monsters (and more importantly, a way out), a portal to another place, or the next part of the dungeon are all possibilities. Even characters that are trapped with seemingly no hope of escape are not totally doomed, as powerful outsiders might notice the party's predicament and come to their "aid," offering a means of escape in exchange for a powerful magic item or dastardly service.

## PERIVAX'S WICKED WATER

**Trap Type:** Aquatic Barricade Trap

**Construction Type:** Complex mechanical

**Activation Type:** Extended

**Trigger:** Local; trapdoor, switch

**Mechanism:** Gravity, spring

**Effect:** Ensnarement, injury

**Attack Bonus:** No attack roll necessary

**Damage:** 4d6

**Save:** Reflex save (DC 22) avoids

**Search DC:** 26

**Disable Device DC:** 31

**Challenge Rating:** 10

**Construction Time/Cost:** 10 weeks; 10,000 gp

Perivax's Wicked Water is a trap designed for no other reason than to torture and extinguish slow-footed trespassers. The trap uses two primary mechanisms to accomplish this: a pit trap that fills quickly with water and a series of locking barricades that slow a trapped victim's escape attempts.

Although the original version was created in the mind of the mad trapsmith Perivax, the basic design has spread quickly throughout the kingdoms. Many wealthy or vengeful nobles use this trap to safeguard valuables or to simply punish traitors and prisoners. This trap may be found in any manner of dungeon complex, stronghold, or castle. It is important to note that this trap may be used in a tower, but consideration should be used in regards to the structure's architecture, as a significant amount of space is necessary for the construction of this trap.

The trap is activated when a character steps onto the concealed trapdoor over the pit trap. A successful Reflex save (DC 22) allows a character to avoid falling into the pit. A character who fails this Reflex save falls 40 ft. into a simple stone pit of the same width as the corridor in which it is found. The fall deals 4d6 points of damage.

When a character lands at the bottom of the pit, the second phase of the trap is activated. The floor of the pit is actually a pressure-sensitive plate that, when depressed, releases the holding mechanisms that hold three large iron barricades in place. These four-inch-thick barricades are mounted at 10-ft. intervals along the length of the pit. The barricades fall and lock into place with the locking mechanisms that also line the pit wall. The locks require a successful

Open Lock check (DC 26) to release.

Additionally, a successful Strength check (DC 20) is required to lift the heavy iron barricades. Characters within the pit may notice that the iron barricades have several 2-inch holes bored through them.

After the barricades fall into place, the trap's final phase is triggered. A 2-ft.-wide trapdoor is opened at the bottom of the pit that leads to an adjacent chamber filled with water. Once opened, the water fills the pit up to the last barricade in 5 rounds. The water rises through the holes bored into the barri-

cedes to fill the pit. If a character is submerged in the water before she escapes, consult the core rules for guidelines on how to handle drowning (DMG 85).

An observant rogue with a suspicious eye may notice the contours of the trapdoor within the passage floor, or possibly smell the faint scent of the heavy oils used to keep the barricade mechanisms in working order. To disarm the trap a rogue need only avoid the trapdoor itself or jam the trapdoor with an object such as a climbing piton.

## PILLAR SQUEEZE

**Trap Type:** Crushing Pillar Trap  
**Construction Type:** Complex mechanical  
**Activation Type:** Instant  
**Trigger:** Local; light sensor  
**Mechanism:** Counterweight, gear  
**Effect:** Ensnarement, identification, injury  
**Attack Bonus:** +20 melee  
**Damage:** 6d6  
**Save:** Reflex save (DC 22) to avoid  
**Search DC:** 27  
**Disable Device DC:** 31  
**Challenge Rating:** 10  
**Construction Time/Cost:** 10 weeks; 10,110 gp

Set amongst other pillars over an intricately worked floor, this trap pins a character between four sliding pillars. Between the damage, the noise, and the trapping of a character, it serves as a useful system for the defense of temples. The pillars are spaced 10 ft. apart, and each is nearly a foot and a half in width.

A Pillar Squeeze mechanism consists of a square room with a pillar in each corner. In the middle of the ceiling on each side of the room is a small hole. A chamber in the ceiling contains a *continual flame* that is used as a light source. The light is emitted as a thin thread at a 45-degree angle to a similar hole in the floor, located on the opposite side of the room. This hole leads to a light sensor. The sensor material takes one shape in light and another in darkness. Attached to a gear, this provides a simple trigger to detect if something is between the two holes.

When all four switches are engaged, the trap is activated. The assumption is that the activation will occur when someone 4 ft. or taller

walks through the middle of the square of pillars. There are other circumstances that might fulfill this condition, such as two characters walking side by side through the pillars.

A counterweight powers the gears, which draw the four pillars to the center of the room with great speed and force. Anyone within the space must make a Reflex save (DC 22) to avoid the oncoming pillars. Anyone who fails takes 6d6 points of damage and is trapped within the pillars. Extricate oneself from the pillars requires a successful Escape Artist check (DC 20). The mechanism resets itself after 10 minutes, or once there are no trapped characters.

In addition to the pillar movement, triggering all four sensors sets off an alarm elsewhere. In large complexes that have multiple instances of this trap, a location board can help the guards pinpoint the exact location of the intruders. Versions without the alarm (such as those in tombs or other unoccupied structures) are CR 8. Alarms by themselves, just arrangements of light sensors, are CR 2. These alarms have a Disable Device DC of 27, requiring the mechanism to be chipped out carefully and disabled. They may also be turned on intentionally by plugging the holes, or spoofed with a carefully placed light source.

The four pillars are mounted on curved tracks. This detail makes it vital for the surrounding area to look similar. These tracks, in the floor and ceiling, can be worked into interesting artwork and designs. The crucial clue is that the trap pillars that make up the track have a slight gap at their bottom, unlike the others. The tracks and swirls in the floor help prevent buildup of dirt or other substances that might clog the light sensors.

Once detected, disarming the trap is relatively straightforward. The trigger mechanism may be a bit confusing to some rogues, but the marks on the pillars give a good indication of the force exerted by the pillars. Based on this information, the space under the pillars can be spiked, preventing their movement.

Periodic maintenance is necessary for the gears, and the counterweight must be reset after a number of uses. It is popular in complexes that make frequent use of columns and pillars. A particularly vivid example is the Sacred Labyrinth of Algol, where a number of these

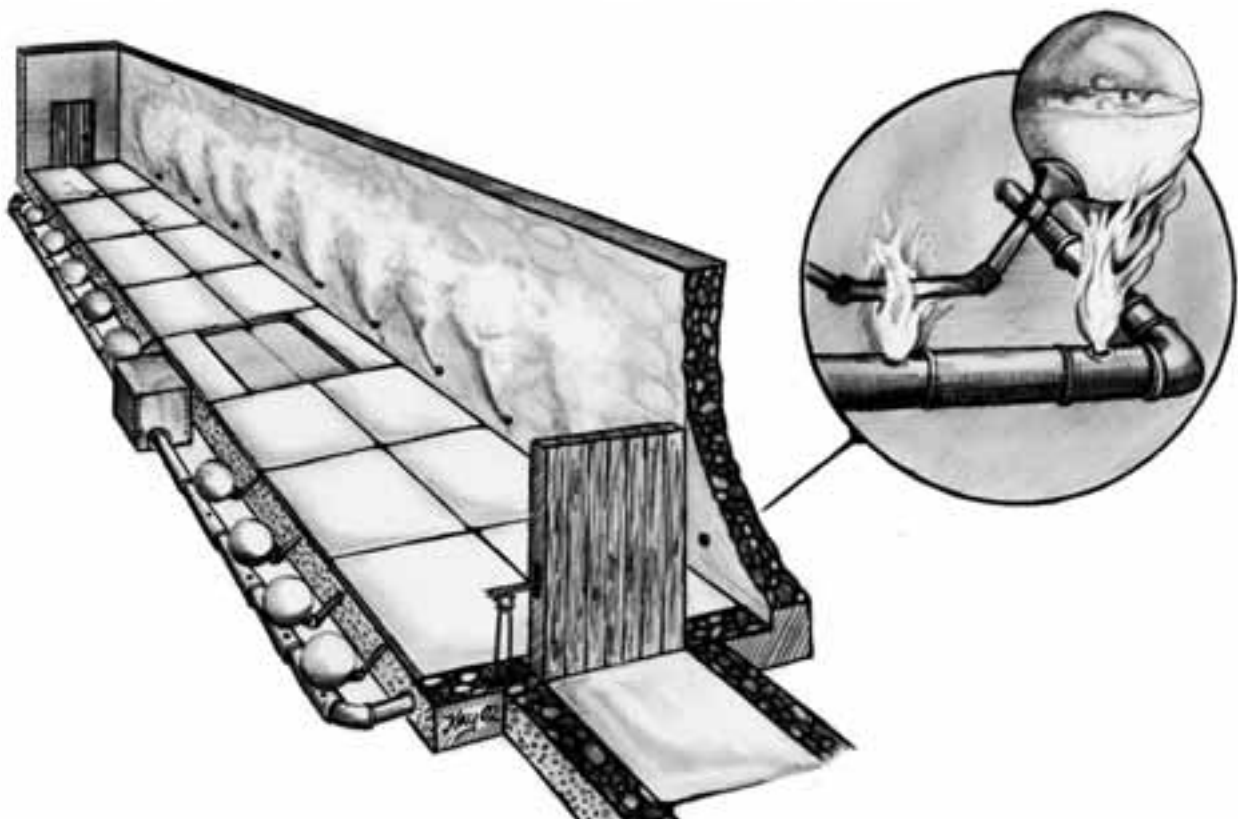

traps are reportedly scattered over a large underground area. The traps were used as the walls of a deadly maze. Only acolytes knew the safe pathway through the expanse. Alas, word of the temple spread. Now, many years after its disciples were slain and treasure plundered, it serves as an icehouse for nearby towns.

## STEAM TUNNEL

**Trap Type:** Steam Trap  
**Construction Type:** Complex mechanical  
**Activation Type:** Extended  
**Trigger:** Local; switch  
**Mechanism:** Pressure, gear  
**Effect:** Ensnarement, injury  
**Attack Bonus:** No attack roll necessary  
**Damage:** Special  
**Save:** None  
**Search DC:** 31  
**Disable Device DC:** 31  
**Challenge Rating:** 10  
**Construction Time/Cost:** 10 weeks; 10,000 gp

Built into a corridor, this is a deadly trap that leaves little residue or other evidence of its use. Popular among dwarves and gnomes, it is a sophisticated machine adapted from steam-powered hammers and other innovations.

The trigger is a simple pressure plate. The cor-

ridor is built over the device, which is powered by a volatile alchemical fuel. When triggered, doors drop shut on both sides of the corridor, and the machine begins to work. It pipes in water that is quickly heated until it turns to steam. The steam is then vented into the corridor.

The damage done by the steam increases over time, as indicated on the following chart.

Round	Damage
1–3	0
4	1d6
5	2d6
6–7	4d6
8–9	3d6
10–11	2d6
12–14	1d6

During the seventh through eleventh rounds, the machine spends its effort lifting a reset counterweight. On the twelfth round, the machine begins to reset. The doors open via the reset counterweight and the reservoirs of water and fuel are refilled.

The doors are AC 4, hardness 8, and hp 60. They have a Break DC of 28. The effective weight of the doors is 2,000 lb. (due to the pressure of the counterweights and mechanisms behind them), so two char-

acters with 21 Strength could push the doors back up into their locked positions.

The pressure plate is the most likely element to be noticed by an observant rogue, followed by the small vents near the top of the walls. Though both are worked into designs featured elsewhere, slight differences in the material used could reveal the nature of the trap. More troublesome is the lack of residue or signs of exactly what effect the trap produces, although the corridor might be a bit more humid than the rest of the dungeon. Still, spiking the pressure plate and vents are sure ways to disable it.

Another version of this trap utilizes a machine to suck the air out of the room. After 6 rounds, suffocation begins. Unlike the steam version, this trap waits a full 5 minutes before releasing and resetting. Poison fumes or acidic gas are other possibilities, but are more likely to leave detectable residues.

## THE ORC CRUSHER

**Trap Type:** Crushing Wall Trap  
**Construction Type:** Complex mechanical  
**Activation Type:** Extended  
**Trigger:** Remote; switch  
**Mechanism:** Gear

**Effect:** Injury  
**Attack Bonus:** +10 melee  
**Damage:** 4d6 plus spikes  
**Save:** None  
**Search DC:** 26  
**Disable Device DC:** 26  
**Challenge Rating:** 10  
**Construction Time and Cost:** 10 weeks;  
 10,000 gp

The Orc Crusher is a trap that uses two crushing, spike-covered walls operated by a series of complex gears to crush and impale unwanted visitors.

The trap itself encompasses a 25-ft. area and is usually found in large-scale orc lairs. Whether it is within an underground complex or disguised in the courtyard of a stronghold, this trap is a staple of orc defense.

The trap is activated from an elevated watchtower, where an orc moves the trap's master switch to set the trap into motion. The first step is the movement of the crushing walls. It takes only two rounds for the walls to reach the crushing point, but the master switch can be moved more slowly to allow for up to 5 rounds until closure. Being crushed between the walls causes 4d6 points of damage.

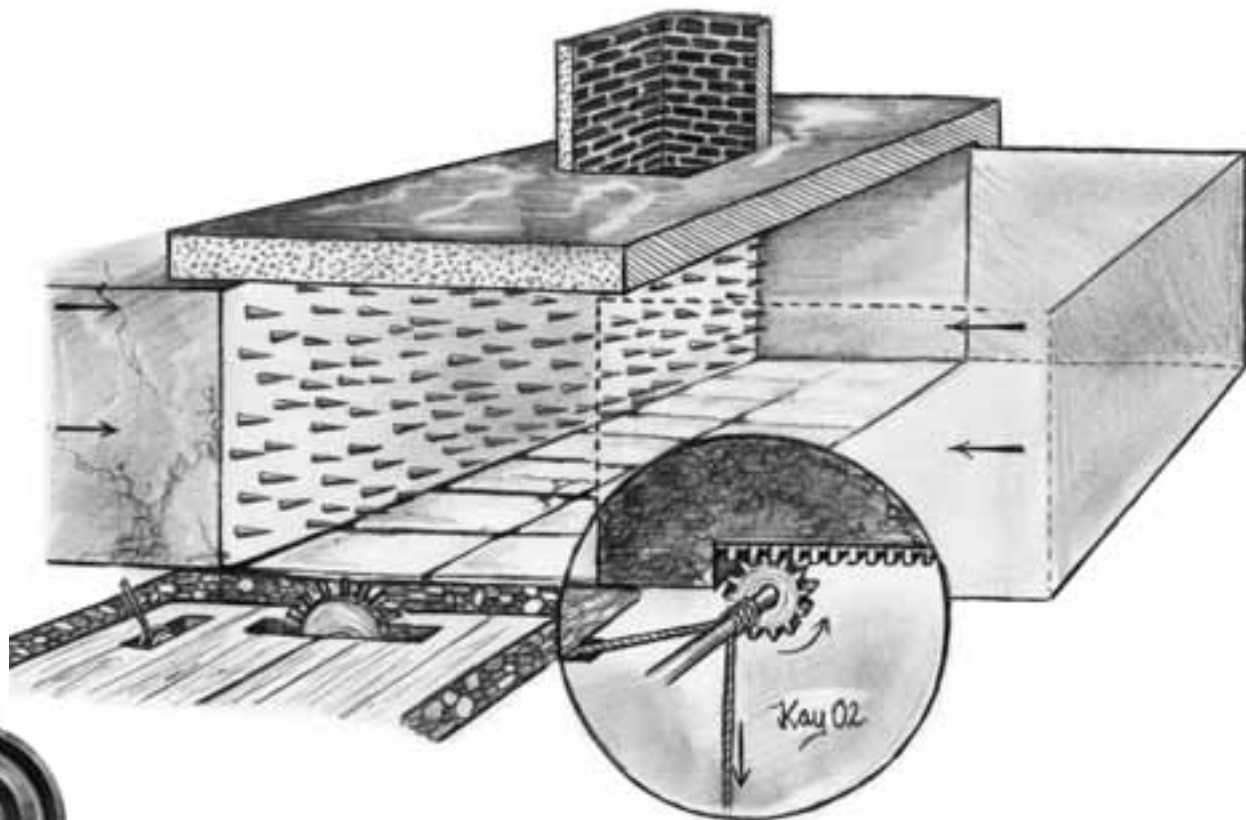

Next is the extension of several metal spikes from the two moving walls. Any character trapped within the Orc Crusher is attacked by 1d4 spikes, which deal 3d6 points of damage per hit.

A rogue may easily notice the grooves carved into a cavern or courtyard floor by the movement of the crushing walls.

To disarm this trap, a rogue must either jam one of the crushing wall mechanisms or reach and disarm the switch mechanism under the watchtower.

## UNHINGED WALL

**Trap Type:** Siege Wall Trap  
**Construction Type:** Complex mechanical  
**Activation Type:** Instant  
**Trigger:** Remote; switch  
**Mechanism:** Gravity  
**Effect:** Injury, hindrance  
**Attack Bonus:** +10 melee  
**Damage:** 18d6  
**Save:** Reflex save (DC 25) avoids  
**Search DC:** 25  
**Disable Device DC:** 22  
**Challenge Rating:** 10  
**Construction Time/Cost:** 10 weeks; 10,000 gp

The Unhinged Wall is a siege trap on a tremendous scale, some versions are as long as 60 feet and as tall as 30 feet, designed to be used by a city's defenders when invaders are scaling its walls. Unlike most traps, the Unhinged Wall is intended to injure or kill dozens or even hundreds of victims at a time rather than individuals or small groups.

The principle behind the trap is simple. A huge and heavy iron lattice, with an outer surface covered in stonework to match the surrounding wall, fits flush over the upper reaches of a city or castle wall. It is anchored at the top of the wall by a series of linchpins and at the bottom by thick hidden hinges. When the linchpins are removed, the ponderous iron lattice drops down like a drawbridge to strike against the wall below it, crushing dozens of soldiers to a pulp and smashing nearby siege towers and ladders to splinters.

With a successful Reflex save (DC 25) a character can escape the Unhinged Wall by leaping

to the ground. Doing so will likely inflict some falling damage, but that is almost always preferable to the punishment the trap deals out. Attackers have been known to make provisions for the trap by wheeling carts heaped with stone into the drop path of the lattice, or by building siege devices designed to counteract it. One such device is a cart with logs mounted at a 45-degree angle positioned to catch the lattice on the way down. In such cases, victims may take half damage or no damage at all.

Unlike most traps, city defenders activate the Unhinged Wall rather than a mechanical or magical trigger. It cannot be disabled from outside the walls. The simplest method of disarming it is to infiltrate the upper walls and trigger it prematurely, when one's allies are not on the wall and at risk. When secrecy is required, attacking its two weak points, the linchpins and the hinges, can do the trick. These are only accessible from within the inner wall and are usually heavily guarded. Disarming the linchpins involves finding some way of anchoring them in the wall. The hinges, of course, must be likewise rendered inoperable.

Detecting the presence of an Unhinged Wall is difficult because there are few telltale signs to give it away. Adept observers may note that the upper wall in this area is slightly thicker than at other points along the wall, or that the gaps between certain stones are a bit wider than usual in some segments.

Cities and castles take some pains to keep the presence of an Unhinged Wall secret to preserve an element of surprise, though this is difficult to manage since it must be installed in full view of everyone. Secrecy is best achieved by installing the trap while the walls are being built. Then it can be swathed in scaffolding and hanging sheets, and the trap is rare enough that it is difficult to identify it merely by viewing its finished design. Obviously, those living near a suitably ancient Unhinged Wall may be unaware of its existence. This is especially true in city ruins, where rusty linchpins can cause an abandoned trap to collapse on unwary explorers.

## WEB OF LIES

**Trap Type:** Impaling Statue Trap  
**Construction Type:** Complex mechanical, magic  
**Activation Type:** Instant  
**Trigger:** Local; magic  
**Mechanism:** Magic  
**Effect:** Injury, ensnarement  
**Attack Bonus:** +11 melee  
**Damage:** 8d6  
**Save:** Reflex save (DC 16) avoids  
**Search DC:** 27  
**Disable Device DC:** 31  
**Challenge Rating:** 10  
**Construction Time/Cost:** 3 weeks; 9,000 gp; 60 XP

This insidious trap is found primarily in the temples of the spider queen, though it has been known to appear in the deep recesses of the underworld as well. It embodies the cruel nature of this foul deity and teaches one of the valuable lessons of her faith: be always devout and obedient to the spider queen, or she will devour you without mercy.

The trap can be found in a small, circular room with a diameter of no greater than 40 feet. There are no evident exits in the room other than the corridor from which the characters entered. At the far end of the room, exactly opposite the entry corridor, stands a 10-ft.-tall statue of a rearing spider with the head of a beautiful woman. The statue's eight multi-jointed legs stick out from the statue in mockery of a mother's welcoming arms. Any character that approaches the statue from the front (comes into either square directly in front of the statue) without prostrating himself triggers the trap. Otherwise the statue remains inert.

When a character triggers the trap, two things happen in rapid succession. First, a *web* spell shoots out from the spider's head. The *web* covers the entire room and requires a Reflex save (DC 16) to avoid becoming entangled. Next, the eight arms of the spider queen snap shut on whatever is standing in front of it. If the PC became entangled in the webs, he automatically fails his saving throw to avoid the closing legs. If he succeeded at his save against the *web* spell, he gains another Reflex save (DC 16) to avoid the snapping stone legs. Failing the save results in the character becoming impaled by eight razor sharp knives of

stone, causing him 8d6 points of damage and automatically grappling him. The character can attempt an Escape Artist check (DC 20) to escape the trap, but even attempting to do so causes him additional damage: 1d6 points if he succeeds and 2d6 points if he fails.

As if this were not enough, the round after the character becomes trapped the entire statue begins to rotate back into a hollow in the wall behind. This is a slow process, taking two full rounds to complete, during which time the character can either escape as outlined above or be rescued by his fellow party members (some of which are likely trapped in the *web*). If he does not escape, he is trapped within a stone cell whose walls are more than 5 ft. thick in any one direction. The stone is hardness 8, hp 900. If his comrades can reach the statue in time, breaking at least three of the statue's legs can free the character. For each leg broken, grant the trapped character a +2 circumstance bonus on his Escape Artist check. The stone legs are hardness 8, hp 30, break DC 26.

Searching the room might provide some clue to the nature of this trap, as the residue left by the *web* spell collects in small quantities over time. Particularly astute characters that examine the statue from afar might receive a Spot check (DC 23) to notice the incredibly sharp edges of the statue's legs. Finally, a rogue that examines the statue's base or the area of wall to which it is attached can fairly easily recognize that it moves in some fashion. In many cases the rogue may mistake this for a secret door, causing him to move around the statue and fall prey to its deadly purpose.

The trap automatically resets after seven days; there is no external mechanism to reset it once it has been triggered. This prevents intruders from finding the mechanism and releasing trapped allies. As a result, it is entirely possible that intruders may find this trap already triggered, and it is possible they can release a trapped individual if they do so. Recognizing the trap for what it is merely requires a Search check (DC 21) around the section of wall in which the character is imprisoned; getting him out is another story altogether.

## BRONZE DRAGON TRAP

---

**Trap Type:** Electrical Trap  
**Construction Type:** Magic  
**Activation Type:** Instant  
**Trigger:** Local; magic  
**Mechanism:** Magic  
**Effect:** Ensnarement, injury  
**Attack Bonus:** No attack roll necessary  
**Damage:** 11d6 electricity  
**Save:** Reflex save (DC 22) avoids  
**Search DC:** 31  
**Disable Device DC:** 38  
**Challenge Rating:** 11  
**Construction Time/Cost:** 3 weeks; 6,500 gp; 220 XP

Utilizing a battery powered by magic, this is at root a quite basic trap. A large gold statue in the ceiling provides one contact. The metal floor provides the other. Anything moving underneath the statue will bridge the circuit, causing electrocution. It provides an effective barrier to entry and avoids an obvious trigger that can be compromised.

The gold statue is that of a bronze dragon, a clue that may escape casual observers. It coils from the ceiling, with numerous points extending downward. The floor has a slight tilt so that anyone entering the area deemed secure is going uphill. This allows bodies to collapse and then roll away from the contact area. The floor is slick, lightly lubricated with a conductive material.

The electricity deals 11d6 points of damage per round, and the character is paralyzed while in the trap. Each round, including the first, the character may attempt a Fortitude save (DC 22) to move out of the danger area. Since the effect triggers before the character is halfway through the trap, this means the character tumbles back the way he came. If the character goes unconscious for any reason, he collapses and rolls out of the effect.

Other characters may attempt to free the victim, but if they touch the character by hand or metal implement, they will also be considered hit by the trap effect. The electrical effect can jump characters and objects in this fashion up to 50 feet away from the trap's origin.

Detecting the trap is difficult. The main signs are scorches on the floor and welts on the gold

from past discharges. A slight smell of ozone may also give a vital clue. An Alchemy check (DC 30) allows the character to identify the lubricant as a conductor of electricity.

Disarming this trap requires a combination of ingenuity, bravery, and luck. A chain or other conductive material can be tossed into the gap. This results in a huge discharge and an explosion of the material used, causing 11d6 points of damage to anyone within 10 feet. Characters with at least one-half cover are safe from the explosion. It takes 1d4 of these discharges for the magical reservoirs to be depleted, after which point it takes 30 hours for the reservoirs to recharge. Once the statue cools off and the fumes disperse (1d6 minutes) the area is safe to pass through.

This trap was designed by gnomes for a bronze dragon. Perfectly safe to any creature with electrical immunity, it provides a distinctive guard against unwanted visitors. The dragon in question paid the fee but found it too dangerous to employ. It has seen a few uses, particularly for mages, but the only active examples are said to be protecting the tombs of well-to-do gnomes and dwarves.

The device has two reservoirs, one temporary and one long term, for the magic used to produce the current. A barrier allows the current to trickle across from the long-term reservoir, recharging the short term one on a continual basis. After a number of uses the entire system runs down, however, and must be replaced. Otherwise, the trap requires very little maintenance. More powerful designs, or versions with less longevity, are certainly possible.

## DUCK AND COVER

---

**Trap Type:** Boulder Pendulum and Water Trap  
**Construction Type:** Complex mechanical  
**Activation Type:** Extended  
**Trigger:** Local; pressure plate  
**Mechanism:** Pressure  
**Effect:** Hindrance, injury  
**Attack Bonus:** +10 melee  
**Damage:** 10d6 (stone block), 5d6 (stone ball)  
**Save:** Reflex save (DC 15) avoids  
**Search DC:** 26  
**Disable Device DC:** 26  
**Challenge Rating:** 11  
**Construction Time/Cost:** 11 weeks; 11,000 gp



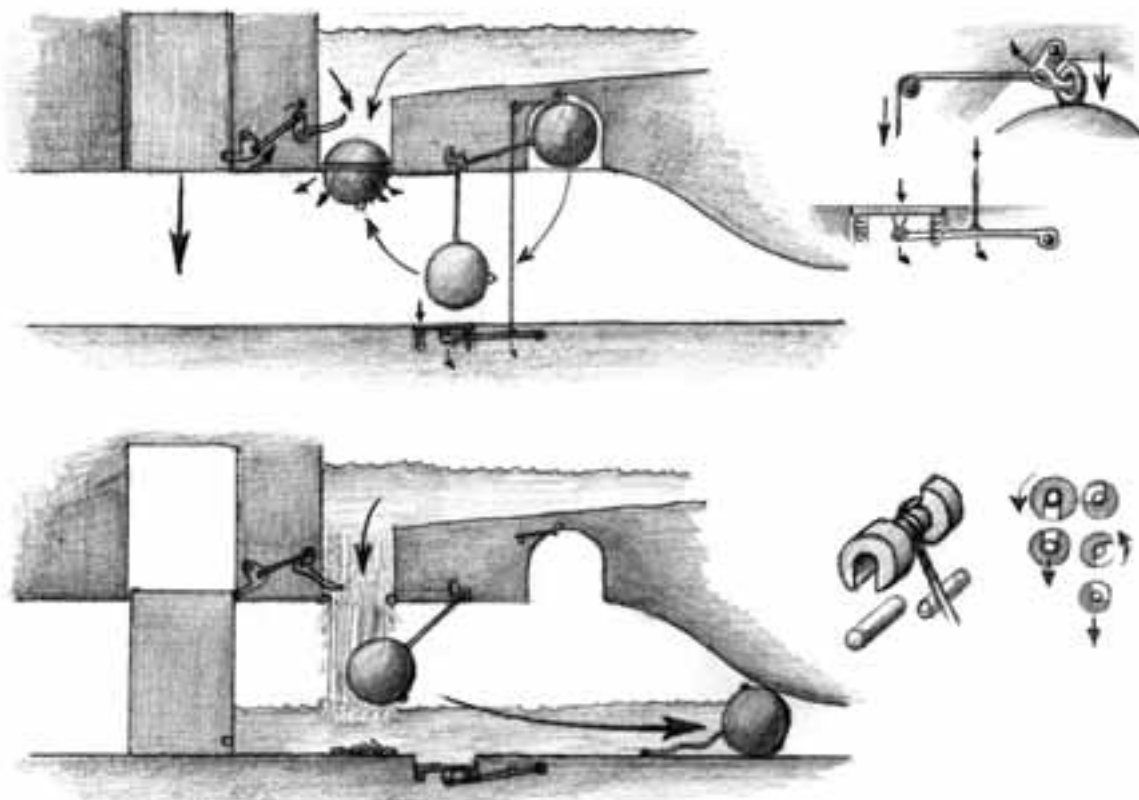

Someone with a love for prolonging the demise of his adversaries designed this incredibly complex corridor trap. As the adventurers make their way down a fairly typical, if slightly taller than normal, corridor they approach a series of well-concealed pressure plates (Search check DC 25). Approximately 40 feet beyond the plates, the party notices that the corridor seems to narrow down into a pipe or tube. The constricted corridor is still big enough for them to crawl through with ease, assuming that they make it past the pressure plates.

Once this trap is triggered, a huge stone ball is released from the ceiling above, 20 feet in front of the party. The adventurers should be able to dodge the stone fairly easily (Reflex save DC 15) as it is smaller than the corridor and clears the floor by almost 3 feet on its downward swing. The stone swings by the party and reaches the ceiling behind the party with enough velocity to smash the brittle stone slab placed there. Behind the slab is a vast reservoir (or possibly even an underground lake or river) that begins to flood into the corridor. Simultaneously, a huge stone block drops into the corridor 20 feet behind the rushing water, blocking the party's retreat.

As the water begins to fill the corridor, the stone ball sweeps back towards its original

resting place. It detaches before reaching the ceiling, and rolls down the corridor towards the narrow pipe. The ball comes to rest after smashing into the end of the corridor, perfectly blocking the only obvious exit from the rapidly filling corridor. There is one hope, however. The cavity where the stone ball rested above the corridor contains a trapdoor that is barred from above and leads to another location within the dungeon.

## FRODERICK'S ICY CUBES

**Trap Type:** Icy Entrapment

**Construction Type:** Magic

**Activation Type:** Instant

**Trigger:** Local; magic

**Mechanism:** Magic

**Effect:** Ensnarement, injury

**Attack Bonus:** No attack roll necessary

**Damage:** 1d6+18 points per round

**Save:** None

**Search DC:** 29

**Disable Device DC:** 29

**Challenge Rating:** 15

**Construction Time/Cost:** 8 days; 8,100 gp and 324 XP

Froderick the Uncanny, archmage and consummate game player, was not always a loveable eccentric. He had a decidedly nasty side to his

personality, and his Icy Cubes are proof of his potential for cruelty. This trap is extremely deadly, but also possible to entirely avoid even by those ignorant of its existence.

Set in a chamber, the trap takes the form of nine 10-ft.-cube pits arranged in three rows of three each. The pits are divided from each other by stone walls only six inches thick (hardness 8, 180 hit points, break DC 40). The tops of the walls form narrow walkways, but they have been topped with rounded, highly polished lengths of wood held firmly into place by iron spikes. The outer sides of the eight pits that abut the sides of the room itself do not have ledges of any sort, thus it is impossible to walk around the room using the walls for balance.

It is possible, however, to walk along the slippery, narrow divides between the pits. Doing so requires a Balance check (DC 25). A successful check lets a character move at half speed for one round. Failure means the character cannot move at all for 1 round. Failure by 5 or more means the character falls into the pit, and this is when the real danger begins. Touching the floor of a pit activates the magical trap and fills the cube with solid ice (as the *wall of ice* spell). Note there is no saving throw to avoid being trapped in the ice.

Death comes swiftly to a character imprisoned in the ice. He takes 1d6+18 points of cold damage per round until either all of the ice is removed from the pit or until he is removed from the pit. The ice can be removed or breached just as a *wall of ice* (hardness 0, 360 hit points, break DC 33). Carefully chipping through 180 hit points of ice opens a tunnel through which the trapped victim can travel. Once freed, assuming the victim is still alive, he can climb out of the pit (Climb check DC 30 if ice still remains, DC 25 otherwise).

In the center of each pit's floor is a small, faintly etched rune. It is difficult to detect, especially since a rogue cannot crawl about on the floor looking for it without activating the trap. Disabling the trap entails identifying the active principle of the rune and scratching it out with a piece of metal or other suitable tool. Again, since the rogue cannot actually be on the floor, disabling the rune proves difficult.

A DM who wants to fully exploit this trap's design should add small amounts of treasure or

other bait to one or more of the pits. The presence of flying monsters that attack balancing characters increases the deadliness of the chamber.

## VESHER'S VICIOUS GRINDER

**Trap Type:** Pit and Blade Trap  
**Construction Type:** Complex mechanical  
**Activation Type:** Instant  
**Trigger:** Local; trapdoor  
**Mechanism:** Gravity, gear  
**Effect:** Ensnarement, injury  
**Attack Bonus:** +15 melee  
**Damage:** 4d6 (fall), 10d6/5d6 (grinders)  
**Save:** Reflex save (DC 24) avoids  
**Search DC:** 31  
**Disable Device DC:** 31  
**Challenge Rating:** 15  
**Construction Time/Cost:** 15 weeks; 15,000 gp

Vesher's Vicious Grinder is a hideous trap that uses a 40-ft.-deep pit trap and a series of complex gears to spin up to three large, bladed grinder wheels. Entrapment is in no way this trap's primary function; it is designed to kill.

This trap is placed within deep dungeon complexes or vaults and is used to guard the builder's most secured areas. Although, some more financially secure builders have been known to use this trap as a simple deterrent against trespassers or thieves.

This trap's first step is activated when a character steps onto the trapdoor that covers a 40-ft.-deep pit trap. A successful Reflex save (DC 24) is required to avoid the collapsing trapdoors. The release of the trapdoors triggers a series of complex gears and pulleys that sets the large metal grinder wheel into motion for five rounds. If a character fails her saving throw, she falls 40 feet and suffers 4d6 points of damage from the fall, as well as 10d6 points of damage from the blade-covered grinder itself. As mentioned, the large grinder spins for five rounds before requiring five rounds to reset itself.

The second step of this trap activates after two rounds of the spinning activity from the large grinder. At the beginning of the third round, two smaller grinder wheels fall from two of the pit's walls and begin to spin five feet above the large grinder. The smaller

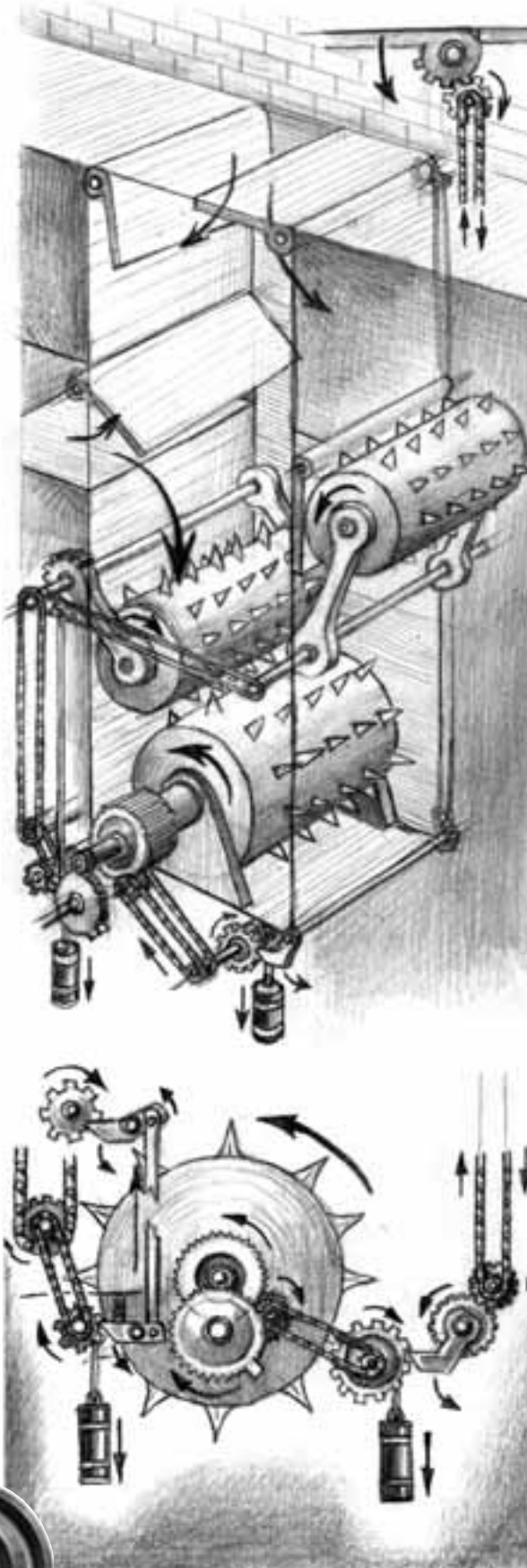

grinders must make a successful melee attack to strike a trapped character, and each deals 5d6 points of damage on a successful attack. The smaller grinders spin for three rounds and stop along with the larger grinder to allow the automated gears to reset themselves. The larger grinder is weight sensitive and activates after five rounds, unless a trapped character can somehow climb the walls (Climb check DC 20) or find another means of escape.

When all three grinders are active, a trapped character must make a successful Reflex save (DC 20) to gain her footing. Failure indicates that the grinders toss her around, causing her to lose her Dexterity bonus to Armor Class and making it impossible for her to perform more than a partial action in the round. A Reflex save is required each round the trap is active.

A clever rogue may notice the trapdoor in the passage floor or smell the faint smell of the mechanical oil that is used to keep the gears loose and active. If triggered, a rogue may disarm the trap by making a successful Climb check (DC 20) to reach the small master gearbox that is near the trapdoor opening at the top of the pit. Once the gearbox has been sabotaged, the grinders cease functioning.

## WELL OF TENTACLES

**Trap Type:** Siege Item Trap

**Construction Type:** Magic

**Activation Type:** Instant

**Trigger:** Local, magic

**Mechanism:** Magic

**Effect:** Hindrance, injury

**Attack Bonus:** +15 melee

**Damage:** 1d10

**Save:** None

**Search DC:** 33

**Disable Device DC:** 33

**Challenge Rating:** 15

**Construction Time/Cost:** 8 days; 7,500 gp; 300 XP

When the walls of a city have been breached, the defenders must do all they can to harry and slow the attacking army until they can summon aid or regroup. The Well of Tentacles is a popular siege defense in larger cities where high-level spellcasters are available.

In appearance, a Well of Tentacles is a harmless fountain placed in a city square. Like any mun-

dane well, surrounding families use it as a watering hole and a rendezvous where they gather to trade gossip. In its dormant state, there is nothing to suggest the well is anything out of the ordinary, though it does register quite high in magical energy if tested.

The well comes into its own, however, when rampaging hordes breach the city's outer walls and fan out to pillage and destroy. When an activation phrase is shouted by a member of the city's elite guard, 20 long, black tentacles snake out of its watery depths, ready to seize and strangle anyone or anything that comes within reach. These tentacles are identical to those summoned by an *Evard's black tentacles* spell cast at 15th level, except that these are 20 ft. long and inflict 1d10 points of normal damage on a successful hit. They can be commanded and controlled by the person who activated the Well, or left to their own devices, in which case they attack at random like the spell.

The tentacles continue to flail about aggressively until destroyed or sent back to the bottom of the well by a defender speaking a deactivation phrase. Destroying all 20 of the tentacles or speaking a special command phrase are the only two ways to disarm a Well of

Tentacles while it is active. Destroying a dormant Well involves climbing down into the muck at the bottom and digging around until the enchanted anchor stone is found (Search check DC 25 to locate). Defacing the rune on the stone destroys the spell and disables the trap, though care must be taken to chip the runes away in the right order or they will activate. Fighting 20 monstrous tentacles at the bottom of a well is not an attractive proposition.

Some cities with deep pockets equip all of their fountains with a Well of Tentacles trap, presenting a daunting obstacle to invading armies. Other settlements trap only wells in key positions, such as squares where several streets intersect, or those near important buildings.

Tentacle Wells are especially effective in settlements of smaller humanoids such as gnomes, halflings and goblins, because the tentacles only react to creatures of Medium-size or larger, allowing them to attack invaders busy grappling with the tentacles.

*Note:* This trap has a very high Challenge Rating, but as a siege trap, it is designed to confront large mobs rather than small parties, and is therefore scaled higher than typical traps.



## PERIVAX'S CHAMBERS OF ETERNAL SLUMBER

**Trap Type:** Stasis Trap  
**Construction Type:** Magic  
**Activation Type:** Extended  
**Trigger:** Magic  
**Mechanism:** Magic  
**Effect:** Ensnarement, movement  
**Attack Bonus:** No attack roll necessary  
**Damage:** None  
**Save:** Will save (DC 24) avoids  
**Search DC:** 34  
**Disable Device DC:** 34  
**Challenge Rating:** 17  
**Construction Time/Cost:** 8 days; 8,500 gp; 340 XP.

Perivax's Chamber of Eternal Slumber is a cruel magical trap created by the mad trapsmith to severely punish greedy, unwanted trespassers. With the use of valuable gems or the allure of magical items, this trap uses a variant *teleport without error* spell, a remote destination, and a *temporal stasis* spell to condemn trespassers to an eternal slumber.

Despite his reclusive nature and insanity, the designs for this trap have somehow found their place in the outside world. With that, this trap may be found in the homes or vaults of the excessively rich, powerful, or paranoid. It is generally only used to safeguard an individual's most prized possessions, due to its finality and high cost. Many cruel barons, dukes, and kings have especially grown fond of the cruelty involved in this trap.

The initial trigger for this trap may be found or placed in several different ways. The most common is within locking mechanisms that safeguard the doors to a noble's vault. If undetected by a rogue, she may attempt to carefully open the locks on the door, only to discover too late that she has activated the trap. Sometimes an item within the vault carries the spell trigger, since a rogue who has bypassed the entryway to such a room may not be as cautious when handling her prize.

Once the trigger is activated, a variant *teleport without error* spell created by Perivax himself is cast at the target (this spell is identical to the spell used in Perivax's Cruel Game, found in *Traps & Treachery*). This spell is identical

to *teleport without error* except that it may target unwilling targets, it teleports only creatures (so clothing and items are left behind), and it is 8th level. A Will save (DC 24) is allowed to resist being teleported to a specific location, chosen and prepared by the builder when the trap is constructed. For example, Perivax himself created a chamber buried several hundred feet below a remote mountain range. The chamber contained no entrances or exits, was constructed of solid iron, and was placed hundreds of miles away from any of his safehouses.

Once a victim materializes, she is immediately stricken with a *temporal stasis* spell. As with the spell description (PHB 265) the trapped victim falls into a state of suspended animation and may only be awakened with a successful *dispel magic* spell (that is assuming that she is ever found).

As stated, this trap has seen many variations that reflect the nature or fetishes of the designers. From weighted coffins at the bottom of a vast lake to fire resistant chambers in the heart of an active volcano, only the imagination and cruelty of the designer limit this trap.

A rogue with an eye for detail may notice the odd sparkle of a trigger-laden gem or pile of coin. She may notice the flawless nature or slight accumulation of dust on an object in a chamber full of clean treasures. With these sorts of warnings, a smart rogue may do best to steer clear of these items. To disarm the trap, a rogue would need to find a means to *dispel* the magical trigger effect or simply avoid the trapped item altogether. Of course, a clever rogue may find another means of disarming the trap with her Disable Device skill, but with a failure of 5 or more, she activates the trap accidentally and suffers the dire consequences of her actions.

# CHAPTER THREE

# NEW POISONS

CHAPTER THREE: NEW POISONS

## INTRODUCTION

This section provides a wealth of information on poisons and how to use them in your campaign. Complete descriptions of over 80 new poisons, both mundane and magical, are provided. Poison names and game statistics are designated as **Open Game Content**. All other material in this section is designated as closed content.

## OVERVIEW

Any substance that causes injury, illness, or death when introduced to the body of a living thing is technically defined as a poison. This encompasses an enormous range and number of substances, including many that are not harmful in reasonable doses, such as alcohol and certain medicinal compounds. For a full overview of poison types and the methods of their creation, see *Traps & Treachery*.

## POISON RARITY

Some poisons are easy to find, being the byproduct of a fairly common plant or animal. Others, such as the elemental toxins found

below, are rare and difficult to find, costing time and resources to find them beyond the mere purchase price. The rarity of a poison can also affect Alchemy or Heal checks made to lessen the severity of a poison or to brew an antidote. The rarity types and rules for using such poisons can be found below.

**Common:** Common poisons are relatively inexpensive and easy to find. Even the smallest thieves' guild has access to these poisons, although not all such guilds choose to use such tools. Apothecaries or herbalists in large towns can make these poisons in about a day, and even small town healers can create one or two types of common poisons.

*Gather Information DC: 18; Heal check: +2.*

**Uncommon:** This is the baseline for most magic poisons and some monster and supernatural poisons. At this level, some difficulty is involved in finding a particular type of poison, and only very specialized alchemists and apothecaries have access to the materials and expertise necessary to make them. Large thieves' guilds and even some wizards' guilds can track down these poisons relatively easily, but smaller organizations may have to call in a favor.

*Gather Information DC: 21; Heal check: Standard.*

## TRAPS & TREACHERY POISON RARITY

The rarity of poisons was not taken into account in the first volume of this series, so a list of the poisons found in that book is presented here with their rarity indicated.

Mundane Poison	Rarity	Magical Poison	Rarity
Alcohol	Common	Draught of Wounding	Uncommon
Belladonna	Uncommon	Enfeebling Sting	Rare
Carbon Monoxide	Rare	Ghastly Mist	Uncommon
Caustic Alkali	Common	Paste of Pestilence	Uncommon
Foxglove	Uncommon	Powder of Paralysis	Uncommon
Hellebore	Uncommon	Seasoning of Shrinking	Uncommon
Locoweed	Uncommon	Tasha's Hideous Laughing Venom	Rare
Opium	Common	Touch of the Unholy	Uncommon
Poison Ivy	Common	Will-Breaker	Rare
Psilocybe	Uncommon		
Ragweed Pollen	Rare		
Toadstool	Common		

**Rare:** Rare poisons have either extensive magical components or require materials from troublesome sources, such as a cockatrice feather or the blood of an outsider. These poisons can generally only be found in the collections of the most skilled and experienced apothecaries, as well as wizards, temples, and possibly even master thieves. Acquiring such a substance might entail more than a simple transaction, as those seeking such powerful things are often desperate enough to pay more than gold to acquire them.

*Gather Information DC: 25; Heal check: -2.*

**Unique:** Unique poisons are generally crafted for a specific job that requires precise effects. Often a poisoner or apothecary is commissioned to create a poison with certain specifications, and then the expert goes to work to create it. He must often enlist the aid of druids or wizards whose specialized knowledge can make his work easier. This increases the price per dose quite substantially, often costing 10,000 gp or more for a single application.

*Gather Information DC: 35\*; Heal check: -8.*

\*In this case the information found is related to the poison's creator and possibly its use, rather than the poison itself or where it can be found.

## STANDARD POISONS

These poisons are crafted with natural ingredients and are often alchemically treated in some manner. They do not require the use of magic, either in their crafting or application. These are the most common poisons to be found, although some are incredibly rare due to their specialized ingredients and dire effects.

**Assassin Butter:** This foul butter made from a combination of otyugh milk, diluted ochre jelly, and sugar is surprisingly tasty. Assassins intent on gaining the upper hand in an upcoming confrontation commonly plant it as part of a target's last meal. The butter is an all-purpose poison and a failed saving throw results in 1d2 points of temporary Strength, Dexterity and Constitution damage. Creatures failing a second save suffer 1d4 points of secondary Constitution damage.

*Assassin Butter:* animal nerve; ingested DC 18; 1d2 Str, Dex, and Con; 1d4 Con; 700 gp.

**Abysal Larvae Jelly:** This gray-green jelly is derived from the secretions of newborn demons. When ingested, abysal larvae jelly reacts with the creature's stomach and causes its acids to expand and become dangerously corrosive. A successful Fortitude save (DC 20) indicates that a creature regurgitates the contents of its stomach before the expanding acid levels become dangerous. Creatures that fail

## CORE RULES POISON RARITY

The core rules present many different poisons (DMG 80) whose rarities are presented here.

Poison	Rarity	Poison	Rarity
Small Centipede	Uncommon	Dragon Bile	Rare
Greenblood Oil	Common	Sassone Leaf Residue	Uncommon
Medium-size Spider	Rare	Terinav Root	Uncommon
Bloodroot	Uncommon	Carrion Crawler Brain Juice	Rare
Purple Worm	Rare	Black Lotus Extract	Rare
Large Scorpion	Uncommon	Oil of Taggit	Uncommon
Wyvern	Rare	Id Moss	Rare
Blue Whinnis	Common	Striped Toadstool	Uncommon
Giant Wasp	Uncommon	Arsenic	Uncommon
Shadow Essence	Rare	Lich Dust	Rare
Black Adder	Common	Dark Reaver Powder	Rare
Deathblade	Rare	Ungol Dust	Uncommon
Malys Root Paste	Uncommon	Burnt Othur Fumes	Rare
Nitharit	Rare	Insanity Mist	Rare

the saving throw begin to foam and bleed from the mouth as the acid eats them from the inside out. This causes 2d6 points of acid damage to the creature. An additional Fortitude save (DC 20, -1 per previous attempt) must be made each round until the creature is able to purge the toxin. Upon regurgitation, the creature must make one last Fortitude save (DC = damage taken) or suffer 1 point of temporary Constitution damage for each previously failed saving throw.

*Abyssal Larvae Jelly:* animal irritant; ingested DC 20; 2d6 hit points/round; Con (see text); 1,700 gp.

**Bearmad:** Thought by some to be a sacred drug among barbarian tribes, this drug is mixed with animal fat and smeared on the chest or extremities, causing the character to go into a rage as per the barbarian class ability. However, unlike normal rage, the character is confused and attacks anyone nearby, including friends.

Note that repeated or long-term use can stack fatigued results, possibly resulting in death.

*Bearmad:* plant psychotropic; contact DC 17; Rage; fatigued, confused.

**Blue Death:** When this alchemical concoction is introduced to the bloodstream, it restricts the blood's ability to carry oxygen. Creatures exposed to blue death must make a Fortitude

save or become deprived of oxygen within 1d4 rounds. At the beginning of the first round without oxygen, the creature must make a Constitution check (DC 10, +1 per round) every round or begin to drown (DMG 85).

*Blue Death:* chemical asphyxiant; injury DC 18; drowning; 1,100gp.

**Coward's Bane:** This unusual substance is made from a combination of powdered mummy bone, kobold blood, and sugar, mixed together to form a paste and then boiled in water. After the compound has dissolved, a metal skewer is left in the water while it cools to room temperature. The sugar crystallizes around the skewer, coating it with coward's bane. The skewer is then used as a melee weapon; it has the same statistics as a dagger, but inflicts only 1d2 points of damage. A successful attack injects the poison. An affected target is gripped by violent, terrifying hallucinations that leave him cowering for 3d6 minutes.

*Coward's Bane:* chemical psychotropic; injected DC 14; cowering; no damage; 100 gp.

**Crypt Smoke Candle:** Crypt smoke candles are a combination of powdered mummy rags and beeswax. Burning a crypt smoke candle creates a subtle but deadly smoke. Any creature within 10 ft. of a burning crypt smoke candle must make a Fortitude save every 10 minutes (DC 6, +1 per 10 minutes of exposure) to avoid contracting mummy rot (DMG 75).



## NEW POISONS

Poison	Type	Damage	Price	Rarity
Assassin Butter	Ingested DC 18	1d2 Str, Dex, and Con; 1d4 Con	700 gp	Uncommon
Abyssal Larvae Jelly	Ingested DC 20	2d6 hp/round; Con (varies)	1,700 gp	Rare
Bearmad	Contact DC 17	Rage; Fatigue, confusion	100 gp	Common
Blue Death	Injury DC 18	Drowning; 0	1,100 gp	Common
Coward's Bane	Injected DC 14	Cowering; 0	100 gp	Uncommon
Crypt Smoke Candle	Inhaled DC var	Mummy rot; 0	1,000 gp	Uncommon
Death Glass	Inhaled DC 20	2d6 Con; 2d6 Con	550 gp	Uncommon
Dire Amber	Contact DC 12	1d3 Con; Confusion	200 gp	Common
Dire Urchin Spine	Injury DC 18	2d4 Str; Paralysis	350 gp	Common
Elemental Toxin, Air	Inhaled DC 14	Fatigued; 1d4 Wis	600 gp	Rare
Elemental Toxin, Earth	Injury DC 18	Slow; 1d4 Str	900 gp	Rare
Elemental Toxin, Fire	Contact DC 16	Cold vulnerability; 1d4 Dex	700 gp	Rare
Elemental Toxin, Water	Ingested DC 16	Fire vulnerability; 1d4 Con	700 gp	Rare
Eye-Killer	Inhaled DC 15	1d3 hp + blinded; 1d2 Dex	75 gp	Common
Firemetal	Inhaled DC 14	Metal sickness; 0	60 gp	Uncommon
Foetid Paste	Injected DC 16	Filth fever; 0	5 gp	Common
Ghost Nettle Extract	Injury DC 22	1d4 Int + 1d6 Wis; Confusion	800 gp	Uncommon
Ghost Nettle Smoke	Inhaled DC 18	Confusion; 0	800 gp	Uncommon
Gore-Eye's Treat	Ingested DC 13	1d2 Dex + dazed; 1d4 Str	120 gp	Common
Hellblood Venom	Injury DC 18	Blood thinning; 0	1,400 gp	Rare
Jester's Rash	Contact DC 13	2d6 damage; 1d4 Dex	315 gp	Common
Kruh'rag	Injury DC 15	Nausea; 1d3 Dex	330 gp	Uncommon
Lotus Vinegar	Ingested DC 20	Poison vulnerability	900 gp	Uncommon

*Crypt Smoke Candle:* supernatural disease; inhaled DC see text; Con damage; 1,000 gp.

**Death Glass:** Death glass is created by combining odd materials from several sources, including the bodily fluids of creatures with the Earth subtype and the eyes of the undead. The final result is a transparent liquid that hardens quickly when exposed to moonlight, forming clear, hard, sheets that strongly resemble perfect glass. The resemblance is so strong, in fact, that only a Spot check (DC 25) or Craft (glassblowing) check (DC 18) can tell them apart. So long as death glass is not exposed to sunlight, it is harmless—it can be moved, touched, even tasted without harm.

When exposed to sunlight, however, it begins to emit a deadly vapor that is wholly odorless and invisible. The vapor emerges from the side of the glass opposite the side on which the sunlight is striking. This makes death glass a tool for use in some particularly subtle assassinations. A small piece of it is placed in a window, either replacing some of the natural glass or just left stuck to the inside. This is done, of

course, at night. When the morning sun strikes the window, the poison is released, and the inhabitant of the room dies peacefully in his sleep. Guards outside the door report nothing, and there are no footprints, fingerprints, or other clues. The glass itself dissolves as it releases its poison. Each dose of death glass is approximately four square inches in size. It is a trivial matter to add minor taints to the mixture to color the glass; this allows a piece of death glass to be substituted for a portion of a stained glass window.

*Death Glass:* chemical asphyxiant; inhaled DC 20; 2d6 Con; 2d6 Con; 550 gp.

**Dire Amber:** The nectar of the orange lotus, which blossoms year-round in certain inaccessible jungles, is a mild psychotropic toxin. Some poisoners grow the flowers in hothouses and extract the nectar. The honey-colored liquid can be distilled into a thick, concentrated resin that has a golden brown or dark amber translucent hue. Stored in small pots, dire amber is painted in a thin coat over a surface, preferably one on which the poison's coloration blends well. Initial contact induces

## NEW POISONS (CONT.)

Poison	Type	Damage	Price	Rarity
Metalseep Gas	Inhaled DC 12	Metal sickness; 0	500 gp	Uncommon
Mist of the Fatigued	Inhaled DC 12	Fatigued; 1d4 Con	285 gp	Common
Mouthing Eyes	Contact DC 14	Shaken; Confused	140 gp	Common
Numbwrack	Contact DC 15	Numbness, 1d6 Dex; 1d6 hp, 1d3 Con	325 gp	Common
Palsyroot Extract	Ingested DC 14	1d3 Dex; 1d4 Dex + palsy	150 gp	Uncommon
Pooling Breathtaker	Inhaled DC 12	Exhausted; Unconsciousness, 1d6 Con	400 gp	Uncommon
Rogue's Rouge	Contact DC 16	1d4 Cha; 1d4 Cha	450 gp	Uncommon
Scaly Mold	Inhaled DC 10	1 Con + exhausted; 0	15 gp	Common
Scarejuice	Inhaled DC 18	Panicked; 1d6 Con	35 gp	Common
Silent Whisper	Contact DC 14	Deafened; 1d2 Wis	285 gp	Uncommon
Spiny Toadstool	Ingested DC 16	Violent fit; 1d6 Con	300 gp	Common
Stiffjoint	Injury DC 15	1d6 Dex; 2d6 Dex	405 gp	Rare
Suffer Dust	Inhaled DC 15	Fatigued; Exhausted	15 gp	Common
Sun's Scorn	Ingested DC 18	Varies; 0	450 gp	Rare
Surgeon's Root	Ingested DC 18	1d3 Wis, exhausted; 1d2 Wis, fatigued	300 gp	Common
Troggoil	Inhaled DC 13	Nausea; 1d6 Str	675 gp	Uncommon
Ulatein	Inhaled DC 16	Frightened; 1d3 Str	130 gp	Uncommon
Vertigo	Inhaled DC 11	1 Dex + deafened; 1d3 Dex	750 gp	Uncommon
Violet X	Injury DC 16	1d6 Str, 1d6 Con; 1 Str*, 1 Con*	1,200 gp	Rare
Wizard's Bane	Injected DC 16	1d6 Int; 1 Int*	1,500 gp	Rare

weakness and slight trembling. Full-blown dire amber poisoning causes *confusion* for 30 minutes minus one minute per point of Constitution.

*Dire Amber*: plant psychotropic; contact DC 12; 1d3 temporary Constitution; confused; 200 gp.

**Dire Urchin Spine**: The spines of dire urchins are a common weapon among reef-dwelling aquatic races. The spines grow up to 2 feet long and are considered small martial weapons that deal 1d6 points of piercing damage. Creatures struck by a dire urchin spine must make a Fortitude save (DC 18) to avoid 2d4 points of initial Strength damage. Failure of a secondary saving throw results in paralysis for 3d6 rounds. Dire urchin spines lose their potency after 24 hours out of water unless alchemically treated (Alchemy check DC 20) and always expend their single poison dose on a successful hit. These spines are also frequently converted to crossbow bolts with a Craft (fletcher) check (DC 15).

*Dire Urchin Spine*: animal nerve; injury DC 18; 2d4 Strength; paralysis; 350 gp (550 gp when treated for land use).

**Elemental Toxin, Air**: Gathered from floating pockets of impurity on the elemental plane of

air, this poison appears as a vaporous white mist. A flask containing a dose of air elemental toxin can be thrown as a grenade-like weapon or simply uncorked to release the poisonous cloud. The cloud fills a 10-ft.-radius sphere upon release and all creatures within the area must make a Fortitude save (DC 14) or become fatigued (DMG 84) for 1d6+1 hours. Failing a second save, one minute later, results in the temporary loss of 1d4 points of Wisdom. The cloud is not dense enough to provide concealment and disperses in 1d4 rounds (calm) or 1 round (11+mph winds).

*Elemental Toxin, Air*: chemical nerve; inhaled DC 14; fatigued; 1d4 Wis; 600 gp.

**Elemental Toxin, Earth**: Earth elemental toxin is found in small, clay-like deposits on the plane of elemental earth. The substance must be baked onto the blade or point of a weapon in order to be delivered to its victim. Creatures struck by such a poisoned weapon must make a successful saving throw (DC 18) or suffer effects similar to a *slow* spell for 2d6+2 rounds. Secondary damage from the earth elemental toxin is 1d4 points of temporary Strength damage.

*Elemental Toxin, Earth*: chemical nerve; injury DC 18; slow; 1d4 Str; 900 gp.

## NEW DISEASE: METAL SICKNESS

Dwarves have encountered a large number of toxic substances and strange diseases in their existence underground. Mines in particular are frequent sources of arsenic and other poisonous metals. Firemetal is the source of a variety of poisonous effects. It is so named because it is warm to the touch, even underground. Some forms of firemetal give off a natural glow. Nearly all varieties of firemetal cause metal sickness with prolonged exposure.

Low exposure to firemetal, being exposed to diluted amounts of metalseep gas, or brief contact with either substance may cause a low-grade metal sickness.

Heavy exposure to firemetal results in full metal sickness, and frequently death. This level of exposure occurs with careless use of firemetal paint, inhaling dust from firemetal mining operations, and constant exposure to the substance. Concentrated metalseep gas can also produce the sickness, though dwarves have long learned to ventilate such areas properly. Fortitude saves must be made every hour to avoid contracting the disease.

A *remove disease* spell cures the victim of the current strain, but he must make a Fortitude save (DC 16) one day later to completely purge the disease from his system. Failure indicates that trace amounts of the poisonous material are still in his body, causing him to relapse into sickness. A *neutralize poison* spell completely detoxifies the character.

**Metal Sickness:** (low grade) DC 16, 1d3 day incubation; 1d2 Con, 1d3 Str; (full) DC 16, 1 day incubation; 1d4 Con, 1d4 Str.

**Elemental Toxin, Fire:** Extracted from the charred recesses of the elemental plane of fire, this orange shimmering substance appears to swirl with ash and cinders. A flask containing a dose of fire elemental toxin can be thrown as a grenade-like weapon. Struck creatures are engulfed in a swirl of warm ash and must make a Fortitude save (DC 16) to avoid the effects of the toxin as it permeates the skin. Failure of the saving throw leaves the target vulnerable to cold based attacks (the victim automatically fails saving throws and takes double damage from such attacks) for the next 2d6+2 hours. Failing a second save one minute later causes 1d4 points of temporary Dexterity damage.

*Elemental Toxin, Fire:* chemical irritant; contact DC 16; cold vulnerability; 1d4 Dex; 700 gp.

**Elemental Toxin, Water:** Pockets of polluted elemental water are boiled down to create this poison. Water elemental toxin appears to be slightly murky water, and creatures consuming it must succeed at a Fortitude save (DC 16) or become sensitive to fire-based attacks (the victim automatically fails saving throws and takes double damage from such attacks) for the next 2d6+2 hours. Failing a second save one minute later causes 1d4 points of temporary Constitution damage.

*Elemental Toxin, Water:* chemical irritant/nerve; ingested DC 16; fire vulnerability; 1d4 Con; 700 gp.

**Eye-Killer:** This is comprised of two parts salt acid and one part talc, carefully mixed, dried, and crushed into a fine dust make eye-killer. This faintly yellow powder is extremely light, requiring great caution in preparation and packing in tissue for use as a blow tube projectile. A victim who fails his saving throw sucks in a lungful of the dust. Initially, this causes painful blisters in the mouth, throat, and nasal passages, and swells the eyes shut. Secondary effects see the swelling and blisters grow more severe. Blindness persists until healed with appropriate magic or one hour passes.

*Eye-Killer:* chemical irritant; inhaled DC 15; 1d3 hit points and blinded; 1d2 temporary Dexterity; 75 gp.

**Firemetal:** Firemetal was discovered by the dwarves. There are actually many types, some used to generate heat, others that glow continually. Unfortunately, most forms have poisonous byproducts that cause them to be banned in most dwarven communities. Inhaling firemetal dust or ingesting contaminated water or food brings toxins into the body. There are two levels of exposure, depending on both the type of

firemetal and the dosage.

Light exposure to firemetal results in mild metal sickness. Recovery checks are made daily. Heavy exposure results in normal checks. Certain types of firemetal are amazingly toxic, and exposure has deadly consequences. Ingested firemetal immediately causes 1d4 points of temporary Constitution damage, with secondary damage of 1 point of permanent Constitution damage per hour until the character dies or is healed with *neutralize poison* or similar magic.

*Firemetal*: chemical nerve; inhaled DC 14; metal sickness/Con damage; 60 gp.

**Foetid Paste:** Solid wastes are one of nature's most common poisons. Foetid paste is a treatment that increases the virulence of the microbes in waste, and renders it into a thick paste that can be applied to weapons or traps. It is well known for use in the wild, where the material has a good longevity. In dry indoor surroundings, the potency may drop as low as DC 12, but can last at that DC for quite a long time.

The smell is pungent, so it is easy to identify and treat. The first Fortitude save, to see if the character is infected, is at DC 16. Subsequent save DCs are lowered to 14. It otherwise progresses like normal filth fever.

Alchemists may formulate an odorless, clear fluid cultivated from wastes. This forms a quite effective poison for food and drink. Flagons of this toxin can be used to taint water supplies with regular filth fever.

*Foetid Paste*: animal infectious; injected DC 16; filth fever; n/a; 5 gp.

**Ghost Nettle Extract:** The wind-blown howl of a ghost nettle patch may be a precursor to its poisonous potential. When concentrated, the weak toxin of its leaves forms a viscous, mind-altering venom. Failure of a Fortitude save (DC 22) results in initial loss of Intelligence and Wisdom; a second failed save results in a state of confusion.

*Ghost Nettle Extract*: plant psychotropic; injury DC 22; 1d4 Int and 1d6 Wis; 2d6 rounds confusion; 800 gp.

**Ghost Nettle Smoke:** In some savage cultures, ghost nettle extract is burned in the fires of ritual celebration. Any creature within 20 feet of



the burning toxin must succeed at a Fortitude save (DC 18) or become confused for 2d8 rounds. Additionally, Charisma-based skill checks against a creature affected by ghost nettle smoke gain a +4 circumstance bonus for 3d12 minutes.

*Ghost Nettle Smoke*: plant psychotropic; inhaled DC 18; confusion and easily manipulated (see text); 800 gp.

**Gore-Eye's Treat:** As if the trapsmiths of goblin Clan Gore-Eye were not bad enough, there are also the poisoners to contend with. The exact composition of this venom is a clan secret. It seems to be some sort of animal fat, rendered and treated with unknown substances. The result is a virtually flavorless, odorless form of lard that can be readily mixed with a variety of foodstuffs. Heat does not destroy its toxic properties, so it can be cooked. Gore-Eye's treat attacks the nervous system, initially inducing muscle tics, loss of coordination, and dazing. The latter lasts for one round. Secondary effects cause pronounced weakness, which can last several days.

*Gore-Eye's Treat*: animal nerve; ingested DC 13; 1d2 temporary Dexterity and dazed; 1d4 temporary Strength; 120 gp.



**Hellblood Venom:** This dark paste is distilled from the blood of a devil or other fiendish creature native to Hell. The venom is applied to weapons and transferred to the intended victim through contact with their blood. Creatures infected with hellblood venom suffer 1d4 points of bleeding damage per round if the character has any open wounds as their blood becomes thinner and bleeds out more rapidly. The bleeding can be stopped with a successful Heal check (DC 15) and all bleeding can be stopped with the application of any cure or healing spell.

*Hellblood Venom:* animal stimulant; injury DC 18; blood thinner (see text); 1,400 gp.

**Jester's Rash:** This poison first appeared within the earliest days of one of the Free City's most infamous (if not unique) assassins' guilds. The Union of Jesters guildmaster, the mad savant named Arrius Madlaugh, brewed the first dose of this odd, yet effective poison. *Jester's Rash* is a deep red liquid with a thin consistency. Upon contact with a character's skin a chemical reaction takes place in which severe burning, drying, and irritation occur. A successful Fortitude save (DC 13) allows a character to avoid the poison's effects. A

character who fails her saving throw suffers 2d6 points of damage. Additionally, after one minute a second saving throw is required or the victim suffers 1d4 points of permanent Dexterity damage.

*Jester's Rash:* chemical irritant; contact DC 13; 2d6 damage; 1d4 Dex\*; 315 gp.

**Kruh'rag (Orcish Bile):** Those who dismiss all orcs as stupid brutes are only half right. Brutish they are, but not all of them are stupid, and the shamans and witch doctors of orc tribes have learned to effectively use the few gifts that the harsh land around them grudgingly provides. The hideous green-yellow ooze called Kruh'rag by orcs, and Orcish Bile by outsiders, is one such product of their crude ingenuity.

Kruh'rag is spread on blades just before combat. It is almost never used on arrows, as most orcs like to see the effect up close. The initial effect of the poison is instantaneous, gut-wrenching nausea. Those failing their Fortitude save (DC 15) are *nauseated* for 2d4 rounds. Even after the initial damage, the dizziness remains, causing a loss of motor control that can persist for days if not cured.

Kruh'rag is composed of a secret mixture of roots, fungus, and animal parts. No orc will willingly teach the recipe to those not at least partially of orcish blood, but half-orcs who have left their tribes and joined urban society often keep a stock on hand.

*Kruh'rag:* chemical narcotic; injury DC 15; Nausea; 1d3 Dex; 330 gp.

**Lotus Vinegar:** Brewed with rice and the blossoms of black lotus, this tart vinegar can be a delicacy or a death sentence. The vinegar is generally consumed by the wealthy over fish or fresh field greens and is sold openly by the spice merchants of most large cities. Although the lotus vinegar has no poisonous effects by itself, it makes the body more susceptible to nerve poisons if a Fortitude save (DC 20) is failed. Any saving throws made against exposure to nerve poisons within 24 hours of consuming lotus vinegar suffer a -10 circumstance penalty. Because of this, assassins have been known to bribe or mislead the serving staff of a wealthy target to gain the upper hand in a post-meal assassination attempt.

*Lotus Vinegar:* plant nerve/stimulant; ingested (DC 20); poison vulnerability; 900 gp.

**Metalseep Gas:** A particularly common form of firemetal gives off this gas, which loses its virulence after three days. Normally, the gas is not concentrated enough to have much effect. Large amounts of firemetal or mechanisms used to pool the gas can result in this 'poison' form. Exposure causes mild metal sickness.

*Metalseep gas:* chemical infectious; inhaled DC 12; metal sickness; 500 gp.

**Mist of the Fatigued:** Originally crafted during the early days of the trapsmith Perivax's career, this poison has a sickly yellow color in its liquid form. There is no dry form of this poison. No more than one hour after the mixing process, the poison must be placed in a tightly sealed flask or similar container, as any exposure to air activates the poison's gaseous reaction. Once exposed, the poison quickly evaporates into a gaseous form, creating up to a 15-ft. radius cloud with a single dose.

Characters exposed to this gas must make a successful Fortitude save (DC 12) or become fatigued (DMG 84). One minute later, a second Fortitude save is required to avoid suffering 1d4 points of temporary Constitution damage.

*Mist of the Fatigued:* chemical asphyxiant; inhaled DC 12; fatigued; 1d4 Con; 285 gp.

**Mouthing Eyes:** This strange poison attacks the mind itself. Sounds give the impression of color, while objects and people the character sees seem reminiscent of music or odors. The senses of the character are jumbled up. The effects of this poison wear off after 1d6 minutes.

*Mouthing Eyes:* plant psychotropic; contact DC 14; shaken; confused; 140 gp.

**Numbwrack:** Numbwrack is a horrible substance that seeps into the flesh, taking effect slowly. It causes numbness, first, as nerves are destroyed. Within the first minute, application of milk and other substances can draw out the acid, granting a +4 circumstance bonus to the secondary saving throw.

While difficult to make, the substance is hard to detect and long lasting. It can be smeared on surfaces or put into small amounts of liquid. It will penetrate thin leather, but heavy boots and similar protections will guard against it. Water or milk can easily wash the substance off objects that are covered with the poison.

*Numbwrack:* chemical acid; contact DC 15; numbness; 1d6 hp, 1d3 Con, 1d6 Dex; 325 gp.

**Palsyroot Extract:** Typically bitter, palsyroot is often mixed in a sweet drink or sprinkled on meat. The poison soon causes slurred speech and clumsy motion, easily mistaken for the effects of alcohol. Over time, it will also produce a pronounced shaking and difficulty with speech. A mage under the influence of palsyroot has a 20% chance to miscast and lose a spell with a verbal or somatic component, and a 40% chance if the spell requires both. Each day the character gets a Fortitude saving throw (DC 14) to see if the palsy wears off. Lost Dexterity returns at a normal rate.

This substance became notorious during recent feuds within a renowned wizards' guild. Matters had grown so tense that students would slip palsyroot into the drinks of their rivals. Attendance and performance suffered, earning jokes and comments from other guilds. Finally, the leaders of the guild came down hard. They confiscated the possessions of the biggest troublemakers, had some private hearings, and created more restrictive regulations. Those guilty of breaking the new rules found themselves ousted or, in a few notable cases, dying under mysterious circumstances.

*Palsyroot Extract:* plant nerve; ingested DC 14; 1d3 Dex; 1d4 Dex and palsy

**Pooling Breathtaker:** Though this poison gas is not tremendously potent, it has certain attributes that make it effective for a number of purposes. It is virtually undetectable, having no odor or appearance. It is heavier than air and long lasting, so it may last quite a long time in underground lairs or wells. Even ventilated rooms, if the ventilation is placed high, may keep the layer of gas below undisturbed. Lastly, not only is it an asphyxiant, but it also prevents decomposition and oxidation. Fires that are exposed to the gas will be snuffed out (a possible alert to its presence), and the gas prevents rust from accumulating on objects within it. However, it does have a slight tendency to revert to small amounts of weak acid, so its effects are not advised with fabrics or books over long periods of time.

Some dwarves are known to use this substance as a fire control system in mines. In addition, it sees some use in alchemy and forging, when reactions are best without the interference of air.

If a person is exposed briefly to pooling breath-taker and immediately begins taking deep breaths of fresh air, the gas can be flushed quickly from the lungs. Upon making the secondary Fortitude save, the character can be upgraded to fatigued from exhausted. Failing the save causes the character to go unconscious and suffer 1d6 points of temporary Constitution damage.

*Pooling Breath-taker*: chemical asphyxiant; inhaled DC 12; exhausted; unconsciousness and 1d6 Con; 400 gp.

**Rogue's Rouge**: This reddish-brown soft wax is usually sold in small clay pots. It can be used as lipstick provided an antidote is taken first, so that the person wearing the poison is unaffected by it. When it contacts the skin of anyone not immune to its effects (very often via a kiss), it causes a sudden lack of self-confidence and willpower. The person affected begins to blush and stammer, and is far easier to manipulate. It is said that nymph's blood is a key ingredient of this substance, though only those who make the stuff know for sure.

*Rogue's Rouge*: chemical psychotropic, contact DC 16; 1d4 Cha; 1d4 Cha; 450 gp.

**Scaly Mold**: Scaly mold is a tree and crop parasite somewhat common in warm, humid regions. When handled roughly, it lets loose a cloud of spores to which many people are allergic. If a creature's very first Fortitude save succeeds, that creature is not allergic to scaly mold and can never be affected by it. If the saving throw fails, however, the creature is allergic to scaly mold. Normal saving throws for subsequent exposures are allowed, but the creature will always be allergic to scaly mold. The effects are noteworthy, but not life threatening in and of themselves. Scaly mold causes mild illness coupled with exhaustion. The latter can be done away with by a good eight hours of rest. One hour of rest downgrades the condition to fatigued.

*Scaly Mold*: plant allergen; inhaled DC 10; 1 point of temporary Constitution and exhausted; no damage; 15 gp.

**Scarejuice**: Not technically a poison, scarejuice is a blend of alchemically treated urine from a variety of large cats. Its odor is enough to provoke a variety of reactions. Herbivores and other traditional prey animals will react in panic at the scent. If unable to flee and subjected to more of the scent, the animal may

lose health due to mortal terror. Larger herbivores, particularly those protecting young, and other typically aggressive animals will become irritable and easily enraged. Sentient races, most of whom lack a fine sense of smell, may become somewhat nauseated at the sharp odor, but are otherwise unaffected. Animals reacting to the odor may take a long time to calm down.

Scarejuice is most often used to create a barrier. Most animals will avoid the odor, regardless of any other reaction. Though it can make predators more dangerous, on the whole it works fairly well. Less benignly, a small amount can be dabbed on someone covertly, thus provoking reactions from animals the person then encounters.

It is quite difficult to fully wash out the smell, which is one problem with its use. Even a small amount on the hands, imperceptible to a human nose, may still provoke animals, though at a lower DC.

A character may detect and identify the odor with a successful Wilderness Lore check (DC 18).

*Scarejuice*: animal irritant; inhaled DC 18 (12); panicked or enraged; 1d6 temporary Constitution; 35 gp.

**Silent Whisper**: This poison is designed to increase the effectiveness of a rogue and accent her skills of stealth by deafening an opponent. The poison itself is light emerald in color and typically carries a medium consistency. When dried, the poison keeps its emerald color. A successful Search check (DC 12) allows a character to notice the dried poison on objects or weapons. Once the poison is injected into a victim its effects begin instantly unless the character makes a successful Fortitude save (DC 14). A character that fails her saving throw is deafened (DMG 84). One minute later, the poison's secondary damage takes effect and a second Fortitude save (DC 14) is required to avoid suffering 1d2 points of temporary Wisdom damage. *Silent Whisper*: chemical nerve; contact DC 14; deafened; 1d2 Wis; 285 gp.

**Spiny Toadstool**: Within five minutes of consuming the dried cap of a spiny toadstool, anyone that fails a Fortitude save (DC 16) bursts into a violent fit for 3d6 rounds. During the violent outburst, the afflicted individual attacks the nearest creature, even allies, with his most

powerful attack or spell. Those poisoned with spiny toadstool also suffer 1d6 points of Constitution damage at the end of the rage as the poison slowly weakens them.

*Spiny Toadstool:* plant psychotropic/nerve; ingested DC 16; violent fit and Con (see text); 300 gp.

**Stiffjoint:** Cunning kobold alchemists, it is said, concocted stiffjoint while looking for ways to undermine their gnomish enemies' continual use of mechanical men and similar clockwork inventions. Distilled from rust monster blood and enhanced by the spores of metal-eating molds, stiffjoint is a reddish-brown liquid with the consistency of molasses. Close examination will show it is not a liquid, however, but a very fine powder whose grains adhere so strongly to each other that it seems to be a highly viscous fluid.

When used against any construct, stiffjoint acts as a debilitating poison. The effect on the target is quite visible; at the point of entry, a hideous discoloration spreads outwards, rotting and corroding the victim. Those few constructs gifted with speech scream as their very structure is rotted away from within, leaving them shambling and twitching at best, wholly paralyzed at worst.

*Stiffjoint:* chemical nerve; injury DC 15; 1d6 Dex; 2d6 Dex; 405 gp.

**Suffer Dust:** Suffer dust is a simple collection of spores and pollen mixed together. It causes unpleasant reactions in most races. The nose clogs up, eyes start running, and the character soon feels weak and tired.

In areas where there is little air flow, such as underground, a dose can cover a 10 ft. by 10 ft. space. It is kicked up as people walk through. Otherwise, the dust must either be blown into someone's face or delivered to them by some other means.

*Suffer Dust:* plant allergen; inhaled DC 15; fatigued; exhausted; 15 gp.

**Sun's Scorn:** Extracted from the remains of a vampire that has been destroyed with sunlight, this heavy black oil seems to swirl and undulate within itself. Sun's scorn has a faintly fermented odor and, therefore, is frequently introduced to its victims through wine or ale. Because of its weight, the poison mixes only partially with other liquids and concentrates in the lower half of the fluid's volume. Drinking half of a mug of ale mixed with sun's scorn would have no effect on a creature because the strength of the







dose would still be in the bottom of the mug. The ingested oil is slowly secreted through the victim's skin for the next 1d12+12 hours. When exposed to direct sunlight the sun's scorn becomes superheated, causing 1d3 points of heat damage each round that the creature remains in the sun.

*Sun's Scorn:* animal irritant; ingested DC 18; hit point damage (see text); 450gp.

**Surgeon's Root:** The root of the hoamis tree, an alpine evergreen, is a powerful narcotic often used in medicine when magical healing is not available. The root can be chewed or boiled in a broth and then consumed. It induces stupor and exhaustion. If both initial and secondary damage takes hold, the patient is fatigued rather than exhausted. Also, for each damage that applies, the patient gains six hit points. These hit points are not lost first the way temporary hit points are. This latter quality makes surgeon's root a useful tool for keeping a patient alive through such drastic procedures as amputations.

*Surgeon's Root:* plant narcotic; ingested DC 18; 1d3 temporary Wisdom and exhausted; 1d2 temporary Wisdom and fatigued; 300 gp.

**Troggoil:** Adventurers daring enough to collect the musk glands from troglodytes can make some extra coin providing alchemists with the ingredients for this noxious poison. Converting the Troglodyte musk into troggoil is a simple matter of adding an alchemical preservative that keeps the secretion from drying out. When a flask of troggoil is shattered, all creatures within 30 ft. must succeed at a Fortitude save (DC 13) or suffer the effects of nausea for 2d4+2 rounds. The secondary effects are 1d6 points of temporary Strength damage. The odor of the troggoil lingers in an area for 10 rounds unless there is sufficient wind to disburse it. Troglodytes are not affected by troggoil.

*Troggoil:* animal nerve; inhaled DC 13; nausea; 1d6 Strength; 675 gp.

**Ulatein (Fear Paint):** Ulatein is thin, bluish dye that is manufactured by several barbarian tribes of the northern hills, using a mixture of natural herbs and the crushed brains of magic-wielding or psionic goblins. It is painted onto the exposed skins of warriors of the tribe just before they march into battle. While many credit the terrifying howls and incredible weapon skill of these combatants as the reason that their enemies tend to flee before them,

many sages have concluded that the true reason is the odd nature of their facial paint.

When first applied, *ulatein* has no effect, except to slightly numb the skin of the wearer. After about 15 minutes, however, the slowly drying paint begins to emit an invisible vapor that has the effect of causing abject terror in all who inhale it. Those wearing the paint are immune to its effects. In addition to the terror, the gas causes slight weakness. The two effects together grant the “blue barbarians of the north” a potent edge in combat.

*Ulatein*: plant psychotropic, inhaled DC 16; frightened; 1d3 Str; 330 gp.

**Vertigo**: The dazzling, rare verdant tree frog of certain tropical jungles is the source of this poison. When agitated, the frog lets loose a puff of mist that is a powerful nerve venom. The poisoner places a verdant tree frog in a glass bottle and shakes to provoke the amphibian. The frog is removed, and the bottle cooled. Condensation gathers the venom, and the liquid is poured into a fine talc powder and left for the water to evaporate. What remains is a venomous powder called *vertigo*. It attacks the auditory nerve and inner ear, inducing deafness and loss of balance. Deafness persists until lost Dexterity is recovered.

*Vertigo*: animal nerve; inhaled DC 11; 1 point of temporary Dexterity and deafened; 1d3 temporary Dexterity; 750 gp.

**Violet X**: A combination of natural poisons from a violet fungus tentacle and a xill create a blue honey-like substance that is more powerful than the sum of its parts. Any creature injured by a blade that has been dosed with violet x must make a Fortitude save (DC 16) or suffer 1d6 points of temporary Strength and Constitution damage. Secondary ability damage is permanent and is accompanied by 1d4+2 days of paralysis.

*Violet X*: animal/plant nerve; injury DC 16; 1d6 Str and Con; 1 Str\* and Con\*, and paralysis; 1,200 gp.

**Wizard’s Bane**: This clear liquid is concocted from the cranial fluids of a mind flayer. When introduced into the bloodstream of most creatures, it has a mind-clouding effect that causes Intelligence damage, which can be permanent. Wizards are the most common victims of this debilitating poison and, through the actions of their minions, one of its most valued con-

sumers. Rival wizards have been known to incapacitate one another’s spellcasting abilities through repeated doses. Wizard’s bane is ineffective against aberrations.

*Wizard’s Bane*: animal nerve; injected DC 16; 1d6 Int; 1 Int\*; 1,500 gp.

## MAGICAL AND SUPERNATURAL POISONS

These poisons all require some magical enhancement in order to function as they do. Some are deadly unto themselves, and are simply made more so by the application of magic, but others are innocuous until made otherwise by a spellcaster. Poisons of this type are difficult to craft and can be even more difficult to find, making them all the more deadly when they are applied because of their rarity.

**Anchor Venom**: Created by the acolytes of the Shining Temple during the Time of Displacement, this poison is designed to slow and keep travel-oriented foes in place. The poison itself is a thick liquid with a dark amber color. Oddly, the poison produces no odor once mixed and dries from a dark amber to a light green coloration. One dose of this poison will cover one Medium-size weapon or the tips of 10 smaller weapons (such as daggers or arrowheads). A successful Search check (DC 15) allows a character to notice the discoloration created by a coating of this poison.

When injected into a character (such as through an injury) the poison is activated. Once active the poison covers the subject in a soft green glow. This glow is identical to the effects of a *dimensional anchor* (PHB 195) spell as cast by an 8th-level sorcerer. The poison’s effects last for eight minutes unless otherwise removed. There is no saving throw allowed to resist this poison.

*Caster Level*: 8th; *Prerequisites*: Brew Poison, *dimensional anchor*; *Market Price*: 1,600 gp; *Raw Material and XP Cost*: 800 gp and 64 XP.

**Dust to Dust**: Quite possibly, this is the deadliest supernatural toxin ever created. Like many, it is a blade venom, a thick paste made from the fine dust remains of a *disintegrated* creature, powdered lodestone, corn starch, and a mild acid. A single dose coats the striking portion of any two Small piercing or slashing weapons, or any one Medium or Large piercing or slashing weapon. A creature

## MAGICAL AND SUPERNATURAL POISONS

Poison	Type	Market Price	Rarity
Anchor Venom	Injury No save	1,600 gp	Uncommon
Dust to Dust	Injury Fort DC 19	3,300 gp	Rare
Golem's Bane	Contact No save	1,800 gp	Rare
Hunter's Friend	Injury Fort DC 11	350 gp	Uncommon
Ichor of Chaos	Contact Fort DC 13	100 gp	Uncommon
Kinslayer Draught	Ingested No save	2,100 gp	Rare
Master's Draught	Ingested Will DC 17	2,550 gp	Rare
Oil of Order	Ingested Fort DC 15	100 gp	Uncommon
Pink Smiles	Ingested Will DC 12	50 gp	Uncommon
Shadow Ink	Injury No save	1,400 gp	Rare
Undead Pact	Contact Will DC 20	4,550 gp	Rare
Undead's Foe	Injury No save	50 gp	Uncommon
Withering Draught	Ingested Fort DC 21	6,000 gp	Rare

wounded by a coated weapon must make a Fortitude save (DC 19) or be instantly *disintegrated*. Even if the saving throw succeeds, the victim still suffers 5d6 points of damage.

*Caster Level:* 11th; *Prerequisites:* Brew Poison, *disintegrate*; *Market Price:* 3,300 gp; *Raw Material and XP Cost:* 2,650 gp and 132 XP.

**Golem's Bane:** This substance was created by druids during the Iron Wars with one purpose in mind; the destruction of iron golems. It appears as a thin, cloudy-gray liquid that is used to coat an item no larger than an arrowhead. Since the substance must contain no iron, sling stones are popular agents for delivery of this substance. Once the chemical dries, it is virtually impossible to detect. A successful Search check (DC 30) allows a character to notice the slight discoloration or detect the faint odor that the chemical agent produces.

When the chemical comes into contact with an iron golem (MM 109) or other iron substance, the chemical reacts and becomes a gaseous cloud that measures 10 feet in diameter. Any iron substances that come into contact with the cloud suffer from the effects of a *rusting grasp* spell as if cast by a 9th-level druid. The cloud appears as murky, gray smoke and dissipates after 1 round.

*Golem's bane* is a chemical agent designed to injure or weaken iron-based creatures and

structures rather than a poison, so iron golems and other creatures immune to poison are still affected by this substance.

*Caster level:* 9th; *Prerequisites:* Brew Poison, *rusting grasp*, creator must be a druid; *Market Price:* 1,800 gp; *Raw Material and XP Cost:* 900 gp and 72 XP.

**Hunter's Friend:** The venom of the dazzling verdant tree frog, which forms the basis of the mundane toxin vertigo, is also the key ingredient of this enchanted poison. It is a blade venom, a thick paste made from the fine dust of vertigo, plus corn starch and animal fat. A single dose coats the striking portion of any two Small piercing or slashing weapons, or any one Medium or Large piercing or slashing weapon. Any creature wounded by a coated weapon must make a Fortitude save (DC 11) or suffer 1 point of temporary Dexterity damage and become deafened. Secondary damage requires a Will save (DC 13) to avoid being *held* for 10 minutes.

*Caster Level:* 3rd; *Prerequisites:* Brew Poison, *hold animal*; *Market Price:* 1,050 gp; *Raw Material and XP Cost:* 525 gp and 42 XP.

**Ichor of Chaos:** This oily liquid—an enchanted contact poison—is nitharit infused with a *detect law* spell. One dose coats five square feet of non-porous material, or one foot of porous material. Once the poison dries, it is all but undetectable.

Like mundane nitharit, ichor of chaos causes no initial damage when first touched. Its secondary effect—3d6 points of temporary Constitution damage—only impacts those of a lawful disposition that fail a Fortitude save (DC 13). Neutral and chaotic characters may be exposed to the stuff with no ill effects.

Bandits, orc chieftains and other leaders of a chaotic evil bent often use the ichor of chaos to detect spies in their midst, by passing around a secretly poisoned oath rod or common chalice. One marauding warlord flushed out a seemingly loyal lieutenant by poisoning the tableware—the man was later discovered to be a paladin of some repute.

*Caster Level:* 1st; *Prerequisites:* Brew Poison, *detect law*; *Market Price:* 100 gp; *Raw Material and XP Cost:* 50 gp and 4 XP.

**Kinslayer Draught:** This is a particularly vile poison, first brewed by an exceptionally vengeful and wicked sorcerer. The base poison is derived from green dragon's blood and powdered rotfungus, but special enchantments, notably *cloudkill*, are used in the creation process as well. The result is a tiny amount of poison, no more than two or three drops, which is a transparent green color and glistens in the light, refracting it as if it were a jewel.

When the poison is administered, usually in food or drink, the victim's skin begins to feel warm, then hot, then burning, a combination of intense heat and an unbearable itch. Usually, this is enough to cause the victim to madly shred their clothes to tear at their own skin, but this is not the worst of it. Within a few seconds of ingestion, the victim begins to exude a toxic vapor, thin green tendrils of venomous gas coiling outwards from his flesh. This gas is painful and lethal to all nearby, acting in all ways as a *cloudkill* spell centered on the victim, who is rendered immune to the effects. The Fortitude save DC to resist the effects of the *cloudkill* is 17. If the victim runs, the vaporous cloud travels with him. Thus, a single poisoned victim can kill dozens, which is how the poison got its name. It was given to a nobleman at the event of his firstborn son's wedding, and the resulting slaughter destroyed two dynasties and plunged a powerful nation into a decade of civil war.

*Caster Level:* 9th; *Prerequisites:* Brew Poison, *cloudkill*; *Market Price:* 2,100 gp; *Raw Material and XP Cost:* 1,050 gp and 84 XP.

**Master's Draught:** The powerful, mind-affecting qualities of surgeon's root are harnessed to impressive effect in this ingested poison. Initial damage is 1d3 temporary Wisdom damage and exhaustion. Secondary damage duplicates the *dominate person* spell, with the affected person's master becoming the first creature to issue her a command (Will save DC 17 negates). Since the *dominate person* spell lasts for 9 days, the victim has plenty of time to rest up before assuming her duties as a slave.

*Caster Level:* 9th; *Prerequisites:* Brew Poison, *dominate person*; *Market Price:* 2,550 gp; *Raw Material and XP Cost:* 1,275 gp and 102 XP.

**Oil of Order:** This syrupy liquid is an enchanted and enhanced variation of oil of taggit infused with a *detect chaos* spell. Due to the strange energy it is infused with, this enchanted poison never has a consistent color or flavor—one batch might yield a flavorless colorless liquid; the next might produce a glowing green goop that tastes of sweet sardines.

The oil of order, like regular oil of taggit, inflicts no initial damage when swallowed—and never will harm those who are neutral or lawful in alignment. A chaotic person, however, must make a Fortitude save (DC 15) or fall unconscious.

Lawful frontier communities plagued by chaotic types who prey on locals most commonly use oil of order—often it is given to bartenders, who spike the drinks of suspects. Of course, the oil knocks out chaotic good folk as well as the less kind sorts, so it is of limited utility. Some lawful evil types such as hobgoblins—who are as eager to cull out chaotic evil beings in their midst as chaotic good ones—simply kill anyone who faints after ingesting the poison.

*Caster Level:* 1st; *Prerequisites:* Brew Poison, *detect chaos*; *Market Price:* 100 gp; *Raw Material and XP Cost:* 50 gp and 4 XP.

**Pink Smiles:** Assassins, thieves, and brigands who are engaged in kidnapping or robbery often use this poison. It lulls the victim into a state of careless indifference, making such operations far easier to accomplish. Doses of this poison are often secreted into a mug of ale or beer, making identification of the effects much more difficult. The imbiber must make a Will save (DC 12) or become comfortably numb and affably disinterested in his surroundings (apply the effects of the *daze*

spell each round). One dose lasts for an hour.

Pink smiles is used by a variety of ne'er-dowells, from footpads and prostitutes to press gangs. Some upscale bartenders slip a dose of pink smiles into the drink of an obnoxious customer to calm him down and allow the bouncers to remove him peaceably.

*Caster Level:* 3rd; *Prerequisites:* Brew Poison, *daze*; *Market Price:* 50 gp; *Raw Material and XP Cost:* 25 gp and 2 XP.

**Shadow Ink:** Negative energy distilled into liquid form, this pitch black, oily substance is a supernatural venom intended for use on slashing or piercing weapons. One dose can coat a single Large or Medium-size blade, or two Small ones. Living creatures taking damage from a venomed blade immediately gain 1d4 negative levels, as in the *enervation* spell (there is no saving throw).

Victims stricken with shadow ink regain lost levels after 15 hours have passed. Traditional curative solutions, such as *neutralize poison*, are of no use once the poison has done its damage. *Negative energy protection*, however, may be used to restore lost levels before that period has elapsed, and of course certain high-powered spells such as *limited wish* are equally effective.

*Caster Level:* 7th; *Prerequisites:* Brew Poison, *enervation*; *Market Price:* 1,400 gp; *Raw Material and XP Cost:* 700 gp and 56 XP.

**Undead Pact:** This is a supernatural contact poison made from a piece of bone and a lump of raw meat, slow cooked in milk, corn starch, and sugar to form a crystallized gravy that cools into a gel. A single dose can be smeared over a single 5 ft. square. Any undead creature that comes into contact with the gel is subjected to a *control undead* spell. Assuming a 13th-level effect, this affects a single undead with no more than 26 Hit Dice that fails its Will save (DC 20). Control lasts for 13 minutes.

*Caster Level:* 13th; *Prerequisites:* Brew Poison, *control undead*; *Market Price:* 4,550 gp; *Raw Material and XP Cost:* 2,275 gp and 182 XP.

**Undead's Foe:** Relatively cheap and easy to make, this supernatural blade venom is effective against all undead creatures. It is made from common resin and enchanted with positive energy. A single dose coats the striking

portion of any two Small piercing or slashing weapons, or any one Medium or Large piercing or slashing weapon. Any undead creature struck by the weapon suffers an additional 1d6 points of damage (no saving throw, but SR applies).

*Caster Level:* 1st; *Prerequisites:* Brew Poison, *disrupt undead*; *Market Price:* 50 gp; *Raw Material and XP Cost:* 25 gp and 2 XP.

**Withering Draught:** This poison is milky, almost muddy tan in hue, and represents one of the most devastating supernatural poisons in existence. Those who ingest it must make a Fortitude save (DC 21) or suffer the effects of the *horrid wilting* spell cast at 15th level.

Withering draught is an extremely rare poison that has only one known maker, the water mage Kamus. Enraged that his fiancée left him for a local lord because “he was too old” for her, Kamus locked himself away in his sea grotto. He spent months concocting a huge supply of a new and lethal poison, which was designed to take the bloom of youth off anyone drinking it. On the day of the wedding he set out with his supply, intending to add a little to each vat of wine enjoyed by the guests. Poor Kamus, however, suffered a fatal heart attack when attacked by highwaymen on the road, and his cask of poison disappeared into the underworld. Distilled and rebottled, it has found its way into the caches of the most elite poison suppliers and assassins around.

*Caster Level:* 15th; *Prerequisites:* Brew Poison, *horrid wilting*; *Market Price:* 6,000 gp; *Raw Material and XP Cost:* 3,000 gp and 240 XP.

## MONSTROUS POISONS

Many poisons derive their value from the physical damage they inflict on the victim, or on the supernatural or magical kick they deliver. Others, however, are of value because of magical properties inherited from the creatures from which they are drawn.

**Cockatrice Yolk:** A gooey yellow substance drawn from a cockatrice egg and imbued with the taint of the *flesh to stone* spell, the cockatrice yolk is a venom meant to be applied to a blade. One dose can coat the blade of a single Large or Medium-size slashing or piercing weapon, or two Small ones. Living creatures taking damage from a venomed blade must

# MONSTROUS POISONS

Poison	Type	Price	Rarity
Cockatrice Yolk	Injury Fort DC 15	3,300 gp	Rare
Demonbane	Injury Will DC 17	2,250 gp	Rare
Kiss of the Aboleth	Ingested Fort DC 19	1,600 gp	Rare
Pudding Bean	Ingested Special	1,200 gp	Rare
Vampiric Draught	Ingested No save	1,400 gp	Rare

make a Fortitude save (DC 15). Failure indicates that the victim turns to stone.

There is one small benefit to the stuff—if a person makes the saving throw, he gains temporary immunity from a cockatrice's petrification attacks for 1d8 hours. It is a small enough thing, but those who set out to hunt cockatrices occasionally immunize themselves with cockatrice yolk before heading out—the technique often yields stony results, but it's easier to deal with in a peaceful setting than in the midst of battle.

*Caster Level:* 11th; *Prerequisites:* Brew Poison, *flesh to stone*; *Market Price:* 3,300 gp; *Raw Material and XP Cost:* 1,650 gp and 132 XP.

**Demonbane:** Distilled from celestial blood and holy water, this injected supernatural poison has dire potency against evil creatures from other planes of existence. A single dose coats the striking portion of any two Small piercing or slashing weapons, or any one Medium or Large piercing or slashing weapon. On a successful melee attack against an evil creature from another plane, the creature is forced back to its home plane. A Will save (DC 17) negates the effect, and SR applies to the effect as well. *Caster Level:* 9th; *Prerequisites:* Brew Poison, *dispel evil*; *Market Price:* 2,250 gp; *Raw Material and XP Cost:* 1,125 gp and 90 XP.

**Kiss of the Aboleth:** The elf sage Methus devoted over a century to studying the fell amphibian aboleths, tracking them through the dark watery depths, stealing into their lairs, trading information with them, and battling them. During the course of his dissection studies he discovered that the distilled mucus present on the creature's tentacles had a remarkable and horrifying effect on those who ingested it. Their flesh changed over a matter of

moments into a slimy transparent membrane, just as if they had been struck by an aboleth's tentacle.

Kiss of the aboleth comes in a transparent jelly form. It has a salty, slightly tart taste, which can be disguised by concealing it in bastes and sauces. It is equally effective dissolved in wine, though few wines will mask its unsubtle flavor. The poison takes 1d4 minutes to take effect, after which it behaves exactly like the aboleth's transformation attack. A successful Fortitude save (DC 19) resists the transformation. It is understandably rare, due to the difficulty in obtaining aboleth tentacles, but it is highly sought after by assassins seeking to complicate the lives of desert princes and others for whom water is a premium.

*Caster Level:* 4th; *Prerequisites:* Brew Poison, spellcaster level 8th+; *Market Price:* 1,600 gp; *Raw Material and XP Cost:* 800 gp and 64 XP.

**Pudding Bean:** The pudding bean appears to be a hard, uncooked, and utterly unremarkable black bean. It is in reality a 1 hp black pudding magically locked into a hibernetic state.

If the pudding bean is chewed, the black pudding awakens and immediately attacks for 1 hp of acid damage a round until spit out. If swallowed whole, the victim is in for a much more painful experience. The pudding is awakened when it hits the stomach's digestive juices, and begins to feed on the material around it. The victim notices nothing on the first day except a gnawing hunger as the pudding consumes the food entering the stomach. On the second day the victim experiences intense stomach pains as the young pudding grows larger and increasingly aggressive. Beginning on the third day the character takes a cumulative 1d6 points of damage a day until the pudding is expelled or kills him.

On the first day, inducing vomiting rids the victim of the nascent pudding (causing an additional 1d4 points of damage as it rises up the esophagus). Getting a gestating black pudding out of a person after the first day requires magical measures.

*Caster Level:* 3rd; *Prerequisites:* Brew Poison, spellcaster level 8th+; *Market Price:* 1,200 gp; *Raw Material and XP Cost:* 600 gp and 48 XP.

**Vampiric Draught:** The vampiric draught is a supernatural ingested poison. Its ingredients include the ash of a burned vampire, a vial of unholy water, a pint of red wine, and a drop of humanoid blood. The ingredients are mixed under low heat and then strained through black cloth. The result is about a pint of very dry red wine that holds deadly magic. A creature drinking the wine is subjected to *enervation* and gains 1d4 negative levels (no saving throw, but SR applies).

*Caster Level:* 7th; *Prerequisites:* Brew Poison, *enervation*; *Market Price:* 1,400 gp; *Raw Material and XP Cost:* 700 gp and 56 XP.

## PRANKSTER POISONS

Not all poisons are deadly. Some range from slightly irritating to downright cruel. In the hands of a mischievous individual, these prankster poisons can annoy, humiliate or make for a nasty revenge. When these poisons are added to food or drink, the tainted goods develop a slight discoloration, taste or smell that a victim has a chance to notice. The victim realizes something is amiss with a successful Spot check (DC 20). These poisons could also be added to a magical potion or trap where applicable. A successful Fortitude save negates all the effects and while some are permanent, most wear off over a period of time.

**Angelcap:** The seeds of the angelcap plant imbue an individual with an altered form of the lycanthropy curse. On nights of the full moon, the poisoned victim transforms into a harmless pig and remains in that form until sunrise. Some variants of this poison have been found that change a victim into a camel, a rabbit, a goat, a cat and even a parakeet.

**Arcanbane:** Feared by wizards and sorcerers everywhere, the arcanbane poison wreaks havoc with arcane spellcasting. Anytime a spell is cast, the DM rolls 1d6 and uses the chart below to determine the outcome of the spell. Non-spellcasters, divine spells, natural

spell-like abilities, and magical items are not affected by arcanbane.

1. Spell fails.
2. Spell changes target randomly (if the spell has no target it just fails).
3. Spell uses two magic slots (if the spellcaster does not have an unused slot of equal or higher level as the spell cast, the spell fails).
4. Random spell (another spell of the same level is cast by accident. This new spell is chosen by the DM and does not have to be known by the spellcaster. The spellcaster does not learn an unknown spell by casting it in this manner).
5. Spell works normally.
6. Effect is doubled (the spell is cast as if it the spellcaster used the Empower Spell feat only no cost is required).

**Belted Whipvine:** The belted whipvine pill makes a victim speak backwards. Spells with verbal components are rendered unusable and listeners must make an Intelligence check (DC 15) to understand the reversal gibberish.

**Borbus Berry Juice:** The juice of a borbus berry is a thick, oily substance that permanently changes the color of skin. The color of the berry determines the new skin color. Discolorations first appear only on skin that comes in direct contact with the poison, but it eventually spreads to cover the whole body over a period of 1d4 days.

**Blackcat:** The blackcat poison is a thick, white oil that makes a person unlucky. Victims suffer a -2 luck penalty on all rolls until the poison has run its course.

**Blue Coldmoss:** When ground to a thick, light blue powder blue coldmoss inflicts a mind-numbing blast on its victim and serves as a great distraction when thrown in the face of an opponent. Inflicted characters suffer a temporary loss of 1d6 Intelligence and are stunned for one round.

**Cockatrice Feather:** When tossed in the eyes, the brown cockatrice feather blinds a character for several hours. The blinded individual suffers a 50% miss chance in combat, loses any Dexterity bonus to AC, moves at half speed, and all opponents gain a +2 attack bonus on the blinded character. Blindsight negates these penalties.

## FRANKSTER POISONS

Poison	Type	Duration	Cost	Rarity
Angelcap	Ingested DC 20	permanent	3,500 gp	Rare
Arcanbane	Ingested DC 16	1d4 days	500 gp	Rare
Belted Whipvine	Ingested DC 12	1d2 hours	190 gp	Uncommon
Borbus Berry Juice	Contact DC 17	permanent	500 gp	Uncommon
Blackcat	Contact DC 13	1d3 days	250 gp	Uncommon
Blue Coldmoss	Inhaled DC 15	1d8 rounds	300 gp	Rare
Cockatrice Feather	Contact DC 16	1d6 hours	750 gp	Rare
Crystalweed	Ingested DC 16	1d4 days	500 gp	Rare
Deepcavern Tar	Contact DC 13	1d6+1 hours	250 gp	Uncommon
Flame Viper Venom	Ingested DC 15	1 week	1,000 gp	Rare
Goblin Spit	Ingested DC 14	1d4 hours	100 gp	Uncommon
Ice Moccasin Venom	Ingested DC 15	1 week	1,000 gp	Rare
Laburnum Oil	Ingested DC 14	permanent	400 gp	Rare
Orc Essence	Ingested DC 15	permanent	2,400 gp	Uncommon
Pepperdust	Contact DC 12	1d4 hours	130 gp	Common
Pickle Toad	Ingested DC 17	1d4+1 hours	200 gp	Uncommon
Purple Mushroom	Inhaled DC 18	1d8 hours	950 gp	Uncommon
Spindle Shrub	Ingested DC 18	1d4+1 weeks	1,200gp	Uncommon
Staircase Moss	Inhaled DC 13	1 day	300 gp	Uncommon
Stinkhorn	Ingested DC 14	1d4 hours	175 gp	Uncommon
Tagis Root Shavings	Ingested DC var	1d6+2 hours	120 gp	Common
Tamarack	Ingested DC 15	2d6 minutes	90 gp	Uncommon
Unicorn Tear	Ingested DC 16	1d4x10 minutes	750 gp	Rare
Winch Sap	Ingested DC 16	1d4 days	500 gp	Rare

**Crystalweed:** The crystalweed causes a painful reaction whenever the victim uses a psionic ability. The poison does not affect characters without psionics or psionic abilities that do not require activation. A poisoned individual takes three points of subdual damage each time he uses any psionic ability.

**Deepcavern Tar:** A thick, smoky black gas often found in small pockets underground, the deepcavern tar causes a loud ringing sound in a person's ears, essentially deafening the victim. Poisoned characters suffer a -4 penalty to initiative rolls and Concentration checks, and automatically fail all Listen checks. Deepcavern tar is extremely flammable and feared by miners for its explosive nature. If the gas ignites, it deals 3d6 points of damage to everything within 25 ft. and has a 40% chance to collapse tunnel ceilings. A Reflex save (DC 14) halves the damage.

**Flame Viper Venom:** Similar to the ice moccasin venom, the poison of the flame viper causes the victim's body to radiate intense heat during periods of heightened activity. On a nat-

ural roll of 18 or better in an attack, Reflex save, or a skill check that uses Dexterity or Strength, all flammable material touching the poisoned character's skin ignites. This is especially damaging to clothing. Anyone else who touches the affected character's skin takes 1d3-1 points of fire damage. The fiery effect lasts for the remainder of the round.

**Goblin Spit:** Goblin spit causes a person to belch uncontrollably several times a minute. This can be quite embarrassing in a social situation that requires etiquette or when sneaking past guards. Affected characters suffer a -2 circumstance penalty on all Move Silently and Charisma-based skill checks.

**Ice Moccasin Venom:** During times of heightened activity and stress, the venom of the ice moccasin snake sends a freezing chill throughout a victim's body. On a natural roll of 18 or better in an attack, Reflex save, or skill check that involves Dexterity or Strength, the poisoned character fails the intended action and is stunned for the remainder of the round.





**Laburnum Oil:** There are several forms of the laburnum oil poison. The creator chooses exactly which effect will occur. Laburnum can either shorten or lengthen body parts (limb, ear, nose), cause growth (tail, horns, extra arm), or generate change (feet to hooves). These changes are permanent until the poison is neutralized or an antidote acquired.

**Orc Essence:** Another popular wedding gift, the orc essence pill makes a victim hideous to behold. The poisoned character suffers 1d6 points of temporary Charisma damage. Half-orcs and orcs are immune to this poison since the key material component involves orc blood. Bathing in a nymph's pool washes away the effects of orc essence, though the nymph's are rarely pleased to have such hideous guests.

**Pepperdust:** A red powder often hidden in clothes or armor, pepperdust makes the skin itch horribly. It has no effect on creatures without exposed skin (such as those with heavy pelts) and unlike itching powder, pepperdust cannot be washed off or subdued with healing salves. A poisoned character loses all Dexterity bonus to AC due to itching.

**Pickle Toad:** The saliva of the pickle toad

causes a victim's skin to emit a scent, unnoticeable to everything but frogs that find it irresistible. Any frogs within 10 miles will flock to and follow the scent. The frogs do not attack but are content to merely sit and croak loudly near the poisoned individual.

**Purple Mushroom:** When inhaled, the smoke of a burning purple mushroom causes a victim to suffer from dementia. The DM rolls 1d8 to determine the affliction from the chart below.

1. Uncontrollable paranoia (the victim tries to get away from everyone and everything, including friends, and may become violent if followed or forced to stop).
2. Voices in the head (the victim hears voices that command him to do strange, though generally harmless, things. A Will save (DC 15) ignores the demands of the voices).
3. Ecstasy (the victim sits in a extremely happy stupor and is unable do to anything but eat, drink, walk, and perform simple tasks).
4. Multiple personalities (the victim gains a second personality of the DM's construction. This new personality may or may not know how to the skills, powers or special abilities of the poisoned character).
5. Extreme phobia (the victim becomes incredible scared of something such as claustrophobia, the fear of enclosed places, or monophobia, the fear of being alone).
6. Flashbacks (the victim relives a past event such as a battle or a parade and is oblivious to the outside world).
7. Wonderland (the victim perceives everything in the surrounding world in a twisted or strange manner).
8. Violent (the victim has to kill and maim everything and regardless of class, enters a barbarian rage that does not stop until exhaustion, subdual, or the poison wears off).

**Spindle Shrub:** Created by a wizard who wished to cut down on his pipe habit, the spindle shrub poison causes a person to suffer painful nausea by just smelling or even seeing smoke. This applies to any smoke. Torches, pipes, campfires, burning buildings, and even candles will all cause the poisoned individual to double over in pain. Nauseated characters are unable to perform any actions other than

## NEW CONDITION: INTOXICATION

Characters often find themselves in bars and taverns drinking with the locals to find information or ingratiate themselves to the denizens of a new town. A character can drink up to 8 ounces of weak alcohol (beer, ale, wine, and so on) or 1 ounce of strong liquor (whiskey, for example) per five points of Constitution with no effect. For each dose after that the character must make a Fortitude save (DC 10 + 2 per extra dose) to avoid becoming intoxicated. There are two levels of intoxication: inebriated and drunk.

**Inebriated:** The character begins to feel the effects of his drinking, suffering mild loss of motor skills and other minor consequences. During this time he suffers a -1 penalty to all saving throws, attack rolls, and skill checks. If he fails another Fortitude save due to drinking, he becomes drunk.

**Drunk:** A drunk character has consumed alcoholic beverages far beyond his capacity to handle them. He suffers a -3 penalty to all saving throws, attack rolls, and skill checks. In addition, the character may only take partial actions. If he fails another Fortitude save due to drinking, he falls unconscious for eight hours.

The after effects of such drinking can be harsh. A character who falls unconscious suffers the penalties for being drunk for four hours after he awakens. Drunk characters who sleep for eight hours are considered inebriated for a similar period of time when they wake up.

If a character does not sleep immediately after becoming intoxicated, his condition downgrades one step for every eight hours, but he is also considered fatigued until he gets the proper rest.

leave the area. A Fortitude save (DC 18) allows the victim to forgo the nausea for one round.

**Staircase Moss:** When inhaled, the spores of the staircase moss cause extreme dizziness. Poisoned characters suffer a 50% miss chance in combat and a -4 penalty to Balance and Jump checks, but gain a +2 bonus to AC due to erratic movements.

**Stinkhorn:** Popular at weddings, stinkhorn makes a person smell horrible. Creatures with sensitive noses will attempt to avoid victims of this poison. Victims suffer a -4 circumstance penalty on all Charisma-based skill checks.

**Tagis Root Shavings:** Just a few drops of the tagis root triples the intensity of an alcoholic beverage. Each time a character sips from a tainted drink, he must make a Fortitude save (DC 10 + 1 for each previous sip) or become extremely drunk. Upon failing the first Fortitude save, the character becomes inebriated. Failure of another save means the character becomes drunk.

**Tamarack:** A character poisoned with tamarack suffers 2d6 points of temporary Dexterity

damage. The victim recovers Dexterity more quickly than normal, however, recovering one point per minute after the initial damage.

**Unicorn Tears:** Characters who drink from the unicorn tear must speak the absolute truth and will even volunteer information. After the poison has worn off, the victim feels extremely ill for the rest of the day and suffers a -1 penalty to all rolls until he rests for 8 hours.

**Winch Sap:** Outlawed in most fighting tournaments, the winch sap drains a character's will to attack, giving him a -4 penalty to all attack rolls as most of his swings become lazy and defensive at best.

# CHAPTER FOUR

# PUZZLES & CHALLENGES

## INTRODUCTION

This chapter presents a variety of puzzles, tricks, and challenges that DMs can insert into their games. Where possible the location and composition of these situations have been left generic so as to insure wide applicability. All text in this chapter is designated as **Open Game Content**.

## AWARDING XP FOR PUZZLES

Characters should be awarded experience for bypassing and solving riddles and challenges they face, but such awards can be tricky to determine. In general, award a party of adventurers experience as if they had defeated a single monster with a Challenge Rating equal to the average party level. So a party of 4th level characters would get an XP award as if they had defeated one CR 4 monster. If one player stands out in the solving of a puzzle or riddle, the DM may choose to award further XP to that character.

## PUZZLES

### A GIFT FOR THE GUARDIAN

This puzzle can be found in any large subterranean room, which usually has murals and paintings on the walls and ceiling depicting several situations that focus on an elemental religion and golems of various kinds. The cavern itself is rough-hewn out of the rock, shaped not by the normal pick and hammer of humans and dwarves but rather by the hands of earth elementals. Small braziers scattered around the room burn with an eternal flame. The room is round, with an altar at the center and a large, barred door at the far end.

Two oils are sitting in glass containers on the altar. The glyphs on the containers indicate that one is the Oil of War, the other is the Oil of Peace. These can be read with either a Spellcraft check (DC 25) or Decipher Script check (DC 20). When applied to an iron golem, the Oil of War gives the golem a +2 circumstance bonus to all attack and damage rolls, while the Oil of Peace imposes a -2 penalty to the same.

The doorway has an inscription written in Terran, the language of the earth elementals. If none of the characters are literate in this tongue, a Decipher Script (DC 25) allows a character to puzzle out the meaning. The translation of the text is below.

*“I am shaped by fire  
Rooted from the earth and given form  
Obliged by my creator to bar the path  
None may pass unless they bring the oil.”*

Given the depictions on the walls, and the fact that the first letter of each line spells “IRON,” the adventurers should be able to deduce that the guardian is in fact an iron golem, and they must select one of the gifts on the altar to be allowed to pass freely. As an iron golem is a fearsome challenge for all but the mightiest of adventurers, solving the riddle is likely to be the key to survival. The images painted on the walls are a clue to the correct gift to bring.

The first image shows a cleric of Gramkal (the elemental god of earth) blessing the Oil of Peace at a complex-looking ceremony, with a variety of elemental creatures present. All of the creatures present at the ceremony are being anointed with the oil. A character making a Knowledge (religion) check (DC 15) can determine that the ceremony depicted is the Ritual of Air, celebrated at the spring equinox.

The second image shows a rite known as the Gauntlet of Lightning. It shows a flesh golem, a clay golem, a stone golem and an iron golem. All of the golems except the iron golem are moving through the gauntlet.

The third image shows an iron golem conversing with a series of earth elementals. A successful Knowledge (arcana) check (DC 20) reminds the character that all iron golems created by the sect of Gramkal are able to speak with elementals.

The fourth image shows a priest of the God of Knowledge consecrating a series of constructs to the service of the church. The priest is conducting a ritual that characters making a successful Spellcraft check (DC 20) recognize as rendering the construct immune to the effects of lightning. All of the constructs have been inscribed with a *glyph of warding*.

The fifth image shows the process of joining

the inner temple of the sect of Gramkal. Touching the mural activates a *magic mouth* spell, which repeats the rite in the language of earth elementals. It is clear from the conversation that one must be able to communicate with earth elementals to join the inner temple.

The sixth image shows the beginning of the Ritual of Air. The creatures attending are being blasted with electricity. Some creatures are shown flinching from the blast and fleeing the ritual.

The seventh image shows the inside of the inner temple. The priests and iron golems are shown walking through fire but keeping a careful distance from an air elemental using electrical attacks.

The eighth image shows the scene of a thief stealing the Oil of Peace, attempting to use it, and then dying horribly. An inscription below the scene reads “*So perish all who use the Oil of Peace without the protection of the Ritual of Air.*”

The ninth image shows a flesh golem, a clay golem, and a stone golem being inscribed with *glyphs of warding*. An iron golem stands in the background, making it clear that it will not be so inscribed.

The clues decode as follows:

All iron golems can speak Terran (the third image), therefore all iron golems can serve in the inner temple (fifth image).

Therefore all iron golems prefer fire to electricity (seventh image).

Therefore no iron golem ever passes through the Gauntlet of Lightning (second image).

Therefore no iron golem is ever inscribed with a *glyph of warding* (ninth image).

Therefore no iron golem is ever made immune to electrical attacks (fourth image).

Therefore no iron golem ever participates in the Ritual of Air (sixth image).

So one can conclude that no iron golem is ever anointed with the Oil of Peace (first and ninth image). The correct gift to bring is the Oil of War.

If the Oil of Peace is brought forth, the iron golem animates and attacks the group. What occurs after this and the rewards for bringing the correct gift are left up to the DM.

## DIAL AN ENTRANCE

This puzzle appears on any door, usually one of thick stone or metal, which has no other apparent mechanisms for entry. There are no handles, locks, or even hinges visible. In the center of the door, three round dials appear. Each dial has six letters written on it. The letters are usually presented in Common, but can be written in any language appropriate to the location in which the door is found. (If the script is something other than Common, the DM may want to prepare two sets of player handouts, one with normal letters for those who can read the language, and one with strange symbols for those who cannot.)

The letters on each dial are evenly spaced around its circumference, so that when properly rotated two of the letters will be opposite each other at the center of the dial. When the three dials are all properly rotated, the six letters in the center of the dials spell out the password that allows the characters to bypass the door (OPEN ME). Once the characters have

rotated the dials to spell out any six-letter word, they may push them back into the door. As soon as they are fully depressed, one of two things occurs. Either the dials have been correctly rotated, in which case the door swings open, or the dials are set to an incorrect position, in which case the characters spring the door's trap. The dials pop out and an arc of electricity shoots out among the characters, acting as a *chain lightning* cast by an 11th-level caster. The character that pushed in the dials acts as the primary target of the spell.

Less deadly consequences can be substituted for the *chain lightning* to make this puzzle more appropriate for low-level characters. Some suggestions include *magic missiles* that target up to three characters, a 15-ft. cone of fire dealing 2d6 points of damage to all within its area, and a *confusion* spell that targets whoever depresses the dials. As written, the characters trigger the effect each time they make an incorrect guess. This can be reduced to a one-time penalty to further reduce the difficulty level of this puzzle.



## “DIE”ING FOR THE ANSWER

This puzzle is usually set to guard a private area of a dungeon complex, most often one built by a wizard or a cleric of a god of either law or mathematics. It consists of a wall panel in which are set five runes. The runes are:

- A large equilateral triangle.
- A square.
- A medium-size equilateral triangle.
- A pentagon
- A small equilateral triangle.

When the party approaches, a *magic mouth* activates and makes one of the following demands:

**One:** *“To pass, touch twelve.”*

**Two:** *“A spider’s legs, an ant’s legs, a horse’s legs, and the door shall open.”*

**Three:** *“Sum the hours in a day, only then you’ll see the way.”*

The key is the symbols. Each represents one side of a particular polyhedron, the most common example being found on the dice in front of the players.

The first shape represents 4, the second 6, the third 8, the fourth 12, and the fifth 20. To answer the riddles of the mouth, the symbols must be touched in the correct sequence. The figures glow when touched, and the glow will fade after no figure has been touched for more than 30 seconds. Entering a wrong answer can result in anything from nothing to a *lightning bolt* or *flame strike* spell.

The answers to the sample puzzles are:

**One:** Touch the pentagon.

**Two:** Touch the medium triangle, the square, and the small triangle.

**Three:** Touch the small triangle and the square, or the square four times.

If the players come to understand what the symbols represent, but choose a different method to answer the question (i.e., for question three they touch the 4 and the 6, attempting to multiply) the DM should accept this. The challenge is to figure out which symbols represent which numbers; if the math is correct and logical, the DM should accept the answer.

## FOUR PATHS

A stairway ascends into this room, which is circular and walled with closely fitted stone. There are four doors in the walls of the room, each leading off in one of the four cardinal directions. In one wall, somebody has roughly chiseled a warning, which reads:

*“Beware, traveler, for the gods have warned me that at least one of the warnings here seeks to play you false, and only one path out of here will let you escape with your lives.”*

The door to the north is made of oak, with dragons chasing each other around the frame. Above the door is a sign that reads:

*“Both the east and south doors lead to doom, unless the west does.”*

The eastern door is cloaked in an illusion of creeping flame. The sign reads:

*“The message above the south door is true, unless the northern path is the safe one to take.”*

The southern door is dark black, so black that it seems to swallow the light around it. The sign on the door reads:

*“Both the east and west doors lead to doom, unless this one does.”*

The western door has three bright silver swords engraved into its face. The sign reads:

*“The message above the north door is true, unless the north road is the one to take.”*

If the safe road is the eastern door, the southern door, or the western door, all four signs are true. But the inscription warns the characters that at least one of the signs is false.

The northern door suggests that if the western door is dangerous, then the east and south doors are safe. The southern door indicates that if it is dangerous, then at least one of the east or west doors are safe. Only the signs at the eastern and western doors are true, and the northern road is the one to take.

The DM may place any desired horrible trap behind the other three doors. Many of the traps in this volume are likely to be appropriate.

## FEEDING THE ANIMALS

A stone lion sits along the path, with teeth and claws made of steel. It looks up at the characters and speaks.

*“You must feed me to pass. My food is more evil than the lords of hell, but a greater good than the celestials. It is wanted by the rich and had by the poor. If you eat it, you shall die.”*

If the characters feed the lion, it will of course attack (use stats for a gargoyle or stone golem, depending on the power level of the characters). The correct answer is “nothing.”

## GUARD DUTY

This puzzle door is often used to guard a treasure hoard or other room full of valuables. It appears as a stone door with a bas-relief dragon carved into the center. The dragon’s head sticks out from the door nearly two feet, silently sneering at any who would attempt to enter.

Any character touching the dragon’s head (by searching the door for traps or locks, for instance) causes the head to animate, looking around menacingly at all in the area. It then locks its eyes onto the character that touched it and recites the following riddle:

*“One creature guards the path to the room you seek,  
But first it is I you must defeat.  
Before I bow and let you through,  
Tell me what awaits you.  
One guardian awaits, next in line of four that came before,  
They were green slaad, succubus, lillend, and gnoll,  
what remains behind the door?”*

*Dragon, minotaur, mummy, or witch?”*

The correct answer is mummy. All of the creatures that guarded the room at one time or another have double letters in their names. The mummy is the only one of the given list to duplicate this feature. The DM can print out the riddle and give it to his players if he thinks the visual clues will help them solve it. The character answering the riddle must be

standing before the door, otherwise the dragon sculpture raises its voice and says *“I prefer to be spoken to directly, if you please!”*

Once the correct answer is given, the dragon’s head moves toward the speaking character and eyes him up and down. It then returns to the door and becomes inert. A character need only push down on the dragon’s head (making it “bow” as spoken in the riddle) to cause the portal to open. It closes after one minute, but can easily be opened again merely by speaking the word “mummy.” Of course, particularly nasty DMs might have the riddle be true, in which case a mummy attacks the party as soon as the door is opened.

The penalty for giving an incorrect answer may vary according to the party’s abilities and the DM’s plans for the room beyond. If the room is inconsequential to the adventure at hand, an incorrect answer might simply prevent the characters from passing the door at all. One day must pass before they can try again. Should the characters need to get into the room, then a variety of effects can occur upon giving the incorrect answer:

**Dragon:** CR 2; The animated dragon’s head lights up as if the correct answer has been given. It says *“I’m delighted you chose me, I’ve so long waited to hear those words.”* Then it goes silent again. If the party attempts to bypass the door, it rears up and sprays a 30 ft. cloud of acidic gas into the room. Everyone in the cloud’s area takes 4d6 points of damage, half on a successful Reflex save (DC 16).

**Minotaur:** CR 3; The dragon’s eyes flash red momentarily before it resumes its original position, remaining animated but unmoving. If any character attempts to bypass the door, a giant axe blade scythes out from the door, cutting anyone within 5 ft. of the door for 6d6 points of damage. A Reflex save (DC 16) avoids the blade entirely.

**Witch:** CR 4; The dragon opens its mouth wide and then slowly transforms into a toad. If any character attempts to bypass the door the frog’s tongue lashes out, striking out with a melee touch attack with a +2 attack bonus. If it hits, the character is affected by a *polymorph other* spell, turning him into a toad. A successful Fortitude save (DC 16) resists the transformation.

## PEBBLES

A wizard with a particular interest in the stars created this puzzle to bar entry to his tower. He wished to guard against those without knowledge of the heavens, only desiring to play host to those that shared his interests. Word of the puzzle spread quietly through the land and has been known to turn up in dungeons and other areas where trespassers and adventurers are not welcome.

This odd looking corridor will give even the most seasoned adventurers pause when they encounter it. Several stones float in midair in the middle of a corridor, seemingly having been dislodged from the walls around them. A *wall of force* blocks the passage, both on the characters' side and some 20 ft. away. A plaque on the wall next to the sealed chamber reads:

“Go beyond this hall and the sky is the limit.  
Light my way and I shall guide you through. –  
Solus.”

Characters who make a successful Knowledge (astronomy) or Profession (sailor) check (DC 20) recognize that the stones are set in the same

pattern as a portion of the night sky. Gemstones float in the positions of the planets.

Deactivating the *walls of force* is as simple as casting a *light* spell or similar magic on the stone that corresponds with the location of the sun. Finding this stone requires a Knowledge (astronomy) or Profession (sailor) check (DC 10) once the pattern of the stones is determined. The sun stone is located above and to the left of the plaque, outside the *wall of force*. It radiates no magic, but a Search check (DC 30) reveals to the character that it is smoother than the rest of the wall and radiates a faint natural heat. Destroying the sun stone does not deactivate the *walls of force*; in fact it makes the passage impassable unless the walls can be brought down by other means.

## SQUARE PEGS

A square board is inset into a door where the locking mechanism would normally be built. It has 36 square depressions, each equal in size. Twenty-six of these have rune-covered tiles within them, and 10 are empty. A leather pouch sits in an alcove next to the door, and within the pouch are the keys to opening the portal. Ten tiles can be found within the pouch, each with

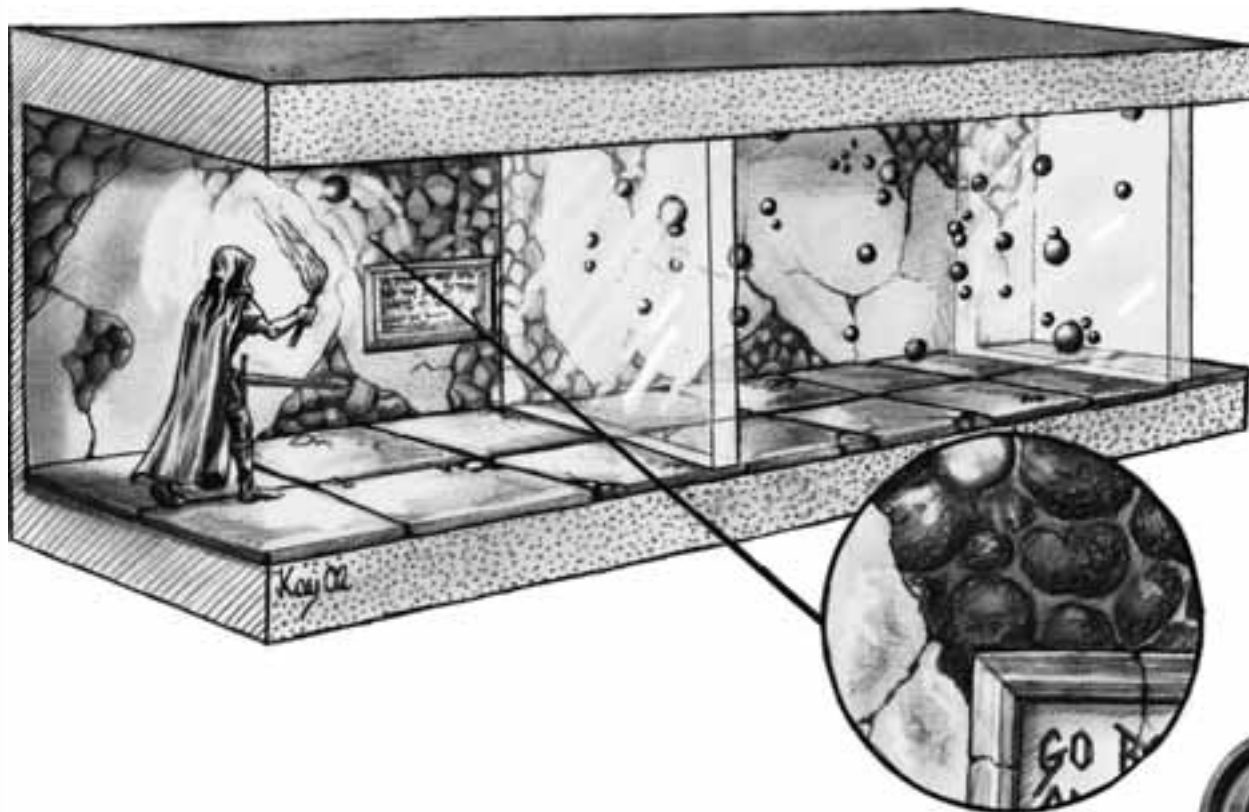





a rune corresponding to one found on the board. In order to open the door, the characters must figure out which tiles go in which squares and place them accordingly. When the last tile is correctly placed, an audible click can be heard as the tiles lock into place and the door's locking mechanism unlatches. The door can then be pushed open and will remain passable until someone with knowledge of the locking mechanism attends to it and places the tiles back in their pouch.

The letters are placed diagonally in alphabetical order, starting with "a" and alternating directions with each line. So the final puzzle looks thus:

A a c a e a  
 B b b d b e  
 A c c c d a  
 D b d c b c  
 A e b c b a  
 F a d a b a

## THE KEY TO SUCCESS

The characters come to a door with a large keyhole. Beside the door rests a table upon which three keys sit. One key is crafted of gold, the other silver, and the last copper. An inscription on the wall reads:

*"One key and one alone can force this door to open. Choose incorrectly and what lies beyond shall never see the light of day. Three clues are given, but only one is true. Use wisdom to guide your hand, lest your dreams be dashed by your own folly."*

The three clues are as follows:

*"The gold key opens the door."  
 "The silver key does not open the door."  
 "The gold key does not open the door."*

The solution lies within the three clues. If only one inscription is true, the first inscription is false. (If it were true, then the second inscription must also be true.)

If the second inscription were true, then the copper key would open the door. But then the third inscription would be true as well, making that statement false. Since that statement is false, the players know that the silver key does in fact open the door.

Should the characters try an incorrect key, a stone slab more than 5 ft. thick drops down behind the door, sealing the tunnel beyond. The characters can hear this as a resounding boom echoes throughout the dungeon (likely drawing wandering monsters to the area).

## THE ROD OF KING JHAERITH V

This is a three-foot-long golden rod, with a red ruby in the center of a crown on one tip. The rod has platinum bands wrapped around the shaft, separated by three inches. The following phrase is inscribed on the rod:

DOMINANT FIFTH, DISAPPEAR  
OLSHT OIRYH ELNVE NDODK INIRE  
OITGY DIMIT

The scepter is actually a *rod of rulership*. To use it, the character must utter the command word while holding the rod. The nonsense phrase provides a vital clue. If you take each fifth letter in the nonsense phrase, eliminating a letter once it has been selected, the phrase can be decoded to read “THE KEY TO LORDLY DOMINION IS DIVINE RIGHT.” The phrase “divine right” is the command word to activate its powers.

## WHEEL OF WOE

A large, brightly-colored disk is mounted into the front of an iron chest. Markings on the chest indicate that the wheel must be rotated to the proper facing before the chest will open. The disk is divided into seven equal wedges, each with a different color. There is an arrow pointing down placed just above the disk, indicating where the proper stopping point is. The following riddle is written on a plaque underneath the wheel:

*“Red is for right, and right makes might,  
Orange is oily, like a slippery tongue,  
Yellow is for yeomen, who serve their masters well,  
Blue is for blood, noble and fair,  
Green is grainy, hearty and filling,  
Purple is placid, like a library old.  
Silver is sprightly, and quick like a fox,  
Now tell me, which color will open this box?”*

Six of the seven lines correspond to different ability scores: red (Strength), orange (Charisma), Blue (Wisdom), Green (Constitution), Purple (Intelligence), Silver (Dexterity). If any of these is chosen before a character attempts to open the chest, he suffers two points of temporary damage to that ability score. Yellow is the only color whose line does not correspond to an ability score, and turning the wheel to that color allows the chest to pop open freely with no harmful effects.





## TRICKS

### AN A-MAZING ILLUSION

A 12th-level wizard can fill a 40-foot by 40-foot by 10-foot space with a *permanent illusion*. He can cast two per day (three if he is an illusionist). That means in two days he can shape at least four *permanent illusions* to fill an 80-foot by 80-foot by 10-foot area, for a total of 6,400 square feet of floor space. Mark the space off on a grid and then fill it in with a maze of suitable complexity. *Permanent illusion* includes visual, auditory, olfactory, and thermal elements, so the effect is extremely convincing. A character who interacts with an illusory wall or ceiling (for example, searches for secret doors or traps) is allowed a Will save (DC 19) to notice that the particular section of the maze he is currently in is actually an illusion. To complicate matters further, add suitable guards who know that the maze is not real.

### THE DOORWAY TO MADNESS

This trick is usually found in complexes

which are, or were, inhabited by individuals with great magical power and sadistic dispositions. It takes the appearance of a simple doorframe. There is no door or blockage of any kind, and the room on the other side of the frame is clearly visible. Only if something is thrown through the doorframe prior to anyone entering will suspicions be aroused, because the thrown item will not appear in the room beyond, but will seem to vanish.

Anyone or anything stepping into the doorframe will find themselves in a *maze*, as per the spell cast by a 17th-level wizard. The same maze exists for each individual who passes through the door; that is, if four people enter the door, all will be in the *maze* concurrently. All of the trapped characters are placed at different points in the maze, and this is where the fun begins, for the Doorway to Madness casts several spells on those who pass through it.

The first is a *veil*. This spell overlays a false image on top of the target, making him appear to be a monster of a sort appropriate to the level of the party. The second is a modified *comprehend languages* that makes speech impossible for the target.

The upshot of this is that, when the entire party has passed through the door, each member finds himself seemingly alone in a magical maze, until he randomly encounters the monsters therein.

A Will save (DC 20) allows the character to penetrate the illusion, but in order to make the save, there must be some reason to suspect an illusion is present.

Each round that passes, there is a 20% chance of one character encountering another. Randomly determine which two party members have met, and tell each one that they see a monster approaching. Try to do this in such a way as the players must think to realize they are encountering each other. Anyone not involved in the encounter hears the screams of battle and the clash of weapons, but cannot move through the maze to the conflict.

If the complex is still inhabited, the controllers of the place almost certainly use scrying devices to watch the intruders battle themselves. Once the spell's duration ends, the characters are deposited in the room on the other

side of the doorframe. If any characters are killed in the maze, their bodies (without the illusory disguise) also end up in that room.

Detecting the odd nature of the doorway without throwing something through it is difficult. A Search check (DC 34) reveals the presence of a trap, possibly by the character noticing the very slight distortions around the doorframe or the unusually high quality of the wood and carving (indicating a possible magical item).

## IMPROPERLY STORED CHEMICALS

Sometimes noxious chemicals are stored for use in a variety of different projects. A death god temple, for example, might store arcane embalming fluids used to animate the faithful dead for eternal guard duty. No site, however, remains occupied forever. Eventually, for whatever reasons, the original occupants leave and the site is left to ruin. Decades later, some group of adventurers come along on some mission or another and explore the ruins, unaware of the dangers that lurk in the shadowy corridors and chambers.

The noxious chemicals stored in this room have slowly eaten through their storage containers and have filled the space from floor to ceiling with flammable, highly poisonous gas. The vapors barely seep through the rubber seal around the door into the storage room, presenting no danger but alerting those with keen senses of smell that something is amiss. Since this is not properly a trap, however, it cannot be disabled, or more accurately it can be disabled by anyone sufficiently clever.

Simply opening the door without dealing with the gas is disastrous. The vapors flow from the room, expanding to fill one 5-ft. square per round to a height of 10 ft., and sending out tendrils into adjacent squares. The gas can fill as many 5-ft. squares as there are in the floor area of the storage chamber. If any open flames are within 5 ft. of a gas-filled square, the fumes ignite violently, causing 6d6 points of fire damage to all within 5 ft. (DC 20 Reflex save halves this damage). If no open flames are in the immediate area, the gas is still highly toxic when inhaled. Anyone caught within a gas-filled square must make a Fortitude save (DC 18) or suffer 1 point permanent Constitution damage initially and 2d6 temporary Constitution damage secondarily. If the gas is

not exposed to flame, it dissipates after 1d4+1 hours, assuming adequate ventilation.

Someone searching the area can make a Search check (DC 16) to detect something wrong with the room beyond, whether it is a faint wisp of smoke or the strong smell of the leaking chemicals.

## MUMMY!

This simple trick is good for a laugh or a groan if nothing else. A particularly jumpy party may even waste a spell or two in response to the perceived threat. It works best in a dark chamber in which many mummified corpses rest eternally upright in raised niches carved into the walls. What curious adventurer could resist not having a look in the niches, especially after the mummies do not animate and attack? If one of the characters does search a niche without first removing the mummy, have everyone make Spot checks (DC 10) as if they are suddenly being attacked. Describe how the mummy in the niche being searched lurches quickly toward the character, arms reaching out, dry mouth dropping open in a silent scream. Everyone not surprised rolls initiative. Give the mummy an initiative of 10. Now, let everyone react however they want. On the mummy's turn, it simply completes its topple to the floor where it lays in a dusty heap.

## ONE PROBLEM WITH SHOOTING FIRST

This trick works best at night in the wilderness, particularly a lightly wooded area through which the characters have been tracking a gang of mounted humanoids. The humanoids know they are being tracked, and want to get the drop on the characters. The humanoids then dismount and dress captured innocents in their tunics, cloaks, and helmets. The disguised innocents are then gagged and tied to the saddles of the horses. The humanoids then send the bound and gagged innocents charging directly at the characters. Allow Spot checks against the humanoids' Disguise check to determine the ruse. Do not forget to modify the Spot check for range and low light. In all likelihood, the characters will open fire on the innocents with ranged weapons and spells while the humanoids move into flanking positions.

# CHALLENGES

## A LACK OF CLASS

This challenge is designed to test the players' ingenuity and to highlight the Use Magic Device skill, which only skilled bards and rogues possess.

An important section of the dungeon is blocked by a stone wall fitted with two handgrips, set in such a way as it is obvious one person must stand between them and grip them. At the top of the wall is written "Savage fury turns the left, while holy sanctity turns the right. One man alone must bridge the gap." To further play up the rogue's less-used skills, this inscription might well be in a lost tongue, requiring a Decipher Script check (DC 22). Close examination of the grips shows a very faint hairline groove surrounding each one, as if they were meant to rotate. It is virtually impossible to turn them (Strength check DC 30), and even if they are forced the passageway remains closed.

To turn the grips, the Use Magic Device skill must be employed, to emulate a barbarian's rage ability on the left grip, while simultaneously imitating the paladin's divine grace ability on the right. If this is done, the grips can be easily turned, and a *stone shape* spell is triggered which opens the wall.

Similar puzzles are often used by thieves' guilds to help train novices in magic device usage without letting valuable magic items into the hands of individuals who are, after all, training to be thieves. A rogue in the group might remember such training from his own youth and key in to the nature of the puzzle. A related Profession check could provide this clue.

Having a paladin and a barbarian each attempt to turn their respective grips will not work; the grips must be turned by the same individual. If a multiclassed barbarian/rogue tries it, he will not need to use the Use Magic Device skill to turn the left grip. Similarly, a multiclassed paladin/rogue need not use his skill to turn the grip on the right.



## BLOODY SLOPE

This challenging dungeon feature is primarily a hindrance, although it can cause a fair amount of damage in the process. It should be placed in a natural corridor underground, where a trickle of water accumulating into a brackish pool does not seem too far out of the ordinary.

The Bloody Slope consists of a steeply sloped passageway, perhaps 10 feet long, preceded by a small pool of brackish water covering no more than 5 feet of ground from wall to wall in the passageway. The pool of water is unclear, so the bottom cannot be seen, but prodding it reveals that it never reaches a depth of greater than six inches. A successful Search check (DC 18) reveals a rocky, uneven surface at the bottom of the pool but nothing else strange. The slope begins out of the pool, so there is no flat ground on the other side.

The slope itself angles upward at about 50 degrees and is covered with a fine layer of slippery cave moss. Several tiny holes at the top of the slope act as the source of the water that fills the pool. Small trickles of water can be seen on the slope, though none seems to be moving with any notable speed. The water serves two purposes: to keep the pool at the bottom filled and to combine with the cave moss to keep the slope slick.

The damaging portion of the area lies underneath the water in the form of jagged rock formations that damage the hands and feet of anyone attempting to walk through the area. Swirling the water does not reveal the jagged rocks, but a *purify food and drink* spell would clear it up enough to see the danger (Spot check DC 15). Only a skilled and observant character can detect the danger otherwise (Search check DC 21). The stones act as a *spike stones* spell to anyone moving through the area, reducing the character's movement and dealing him damage.

Jumping over the water to the slope is relatively easy, but staying on the slope once the character arrives is a different story. The moss makes it incredibly difficult to traverse the slope, necessitating a Climb check (DC 15) from anyone attempting the climb. In addition to the Climb check, upon first contact with the moss a character must succeed at a Balance check (DC 15) or be thrown back into the

water, suffering the effects of the sharp stones yet again. Anyone falling into the water in this way might also suffer wounds to his hands as well as his feet. This imposes a -1 penalty to all attack rolls as well as a 10% arcane spell failure chance to any caster suffering the wounds. These penalties can be removed in the same way as damage from a *spike stones* can be healed (PHB 255).

As soon as one character makes it to the top of the slope he can secure a rope, thus making it easier for others to climb the slope (Climb check DC 5). Characters jumping to the slope and grabbing the rope must still make a Balance check to avoid sliding back into the dangerous pool.

## FANTASTIC BRIDGE

This dangerous structure can be placed anywhere that a deep pit or chasm blocks movement to an important location. The chasm should be at least 30 ft. wide, making jumping over it a virtual impossibility. Two thin columns of rock jut out of the cavern walls nearly 100 feet below the characters, meeting in the center of the chasm and rising to a level point with the cavern in which the PCs are standing. A mechanism that resembles a mushroom lies upon this finger of rock, and a long, flat board is attached to its center. This board is half the length of the gap in the floor, and currently rests on the characters' side of the chasm.

As soon as any weight is placed on the middle of the board, the mechanism activates and begins to turn, causing the board to rotate. A Balance check (DC 12) is necessary to keep from falling off the blade as it begins to whirl. Even if this check is failed, a Reflex save (DC 12) allows a character to grab the blade before falling into the chasm. This, however, causes an automatic one round delay in getting off the blade.

Getting off the blade is more difficult each round the character stays on. It takes a full round for the blade to rotate one turn, so the character may choose to get off on either side of the chasm with equal difficulty. A character can jump off the blade in the first round fairly easily, requiring only a Jump check (DC 10) to avoid damage. A Tumble check may be substituted for any Jump check at a DC



of 5 lower than the current Jump DC. Missing any check by 5 or more results in 1d6 points of damage as the character is thrown hard to the ground, although they still make it to safety.

The blade's velocity increases for the next four rounds, until it is spinning incredibly fast. For each round after the first, increase the Jump check DC by 4 and the damage dealt on a failed check by 1d6. So on the fourth round, the Jump check DC is 22 and the damage dealt by a failed check is 4d6. Additionally, characters on the blade must make a Strength check (DC 10+number of rounds spinning) to hang on to the blade, otherwise they are thrown off in a random direction. This means that 50% of the time the character will be thrown to safety (still taking damage depending on how fast the blade is spinning) and 50% of the time the character will be thrown into the chasm (effects depending on the DM's wishes).

After the fifth round of spinning, the blade slows down at the same pace, each level imposing the same difficulties on characters still on the blade. At the end of the 9th round it stops in its original position. If any more weight is placed on the blade, it begins the process anew.

## SPINNING TARGET

At the end of a corridor a 5-ft.-wide circular portal of marble is mounted into the surrounding rock. Minute fractures can be detected in the marble leading careful observers (Search check DC 15) to conclude that the slab twists open in some fashion. Slightly offset from center is a pattern of circles in alternating colors, the widest of which is close to 12 inches in diameter.

Thirty feet from the marble slab, a shaded box 5 feet to a side can be found. This requires a Spot check (DC 15) to notice as the characters approach the slab, or a Search check (DC 12) if they are actively looking in the area. A character that stands in the slab while wielding a ranged weapon sees the target flash briefly. This is not visible to any other character.

Hitting the target with a ranged weapon is rather simple, as the stationary circle is only AC 7. But after the first hit, things begin to get interesting. The marble slab opens just a crack, leaving about an inch of space through which the other side of the portal is visible. In addition, the slab begins to rotate slowly, increasing the target's AC to 11. With each successive hit,

the slab spins a bit faster and opens a bit further (though never enough for even a halfling or gnome character to crawl through), until the fifth hit causes it to rotate fully open. The target's AC increases by 4 with each hit as well, capping out at AC 23 for the fifth and final shot.

Each time the shooter misses the target, his weapon is magically redirected back to him. The door has a ranged attack bonus of +8, and even if the shooter dodges out of the square he can still get hit. The marble portal is 10 inches thick, hardness 8, hp 150.

## SWINGING PLATFORMS

In this challenge, four circular platforms suspended over a chasm (which could be filled with water, lava, or just be a dead drop) present the characters their only option for crossing to the passageway beyond. Each platform is only 5 ft. in diameter, meaning that jumping from one to the other is beyond the ability of most characters since they cannot take running jumps (except from the original ledge to the first platform). The trick is that one character must jump to the first platform and start it swinging; each is suspended by a chain long enough to allow it to swing near the next disk.

Starting a disk swinging requires an initial Strength check (DC 15), followed by two more successful Strength checks (DC 15) to swing the disk far enough in either direction. Once the disks are swinging, a Strength check (DC 10) is enough to keep them swinging for an additional two rounds. An unattended disk swings for a minute before settling back to its resting position. Jumping from a swinging disk to a still disk requires a Jump or Tumble check (DC 10). Failure indicates the character takes 1d6 points of subdual damage for falling, failure by 5 or more indicates that the character has slipped off the disk and into whatever awaits him below. Jumping onto a swinging platform, whether from stable ground or another swinging disk, is a bit more difficult, requiring a Jump or Tumble check (DC 15) to perform. Characters still take damage for failing the check, but can still make it onto the disk unless they fail by 5 or more, in which case they fall to the dangers below.



## THE COLLAPSING ROPE BRIDGE

One of the classic challenges is the collapsing rope bridge. Whether it breaks naturally, or the adventurers snap it while crossing to deter pursuit, surviving its collapse can be a severe test for a party unprepared for the challenge. If the characters try to cut the rope themselves, adjudicate the attack using the normal rules. If the rope bridge snaps unexpectedly (instead of being deliberately cut), the adventurers can each make a Spot check (DC 15) to see the disaster coming.

At the moment the first rope snaps, the characters may be thrown off the bridge as half of it swings downwards. The characters must make a Reflex save (DC 15) to grab onto one of the ropes. Characters must have at least one hand free to grab onto the ropes; allow them to drop a held item if they wish. If they do not, they may be able to hook a foot in between some of the planks to avoid falling (the Reflex save becomes DC 20 and the character also takes 1d4 points of subdual damage as his legs are yanked unpleasantly).

When the rope finally snaps, the bridge falls against the sides of the chasm it



crossed. Any character within 10 feet of the end of the bridge can make a Reflex save (DC 20) to jump to safe ground. Otherwise, the characters must hold on as they fall and then are slammed against the side of the chasm. They take subdual damage as if they had fallen an equivalent number of feet to their distance from the edge. The adventurers must also make a Strength check to retain their grip. The DC of this check is  $10 + 1$  per 5 feet fallen (e.g., a character 30 feet from the edge of the chasm must make a DC 16 check).

After all this, the characters are more or less fine. They can proceed to climb up the rope bridge to safety, using the normal rules for such activity—unless, of course, they have to fight their way up. See the core rules (PHB 65) for rules on fighting while climbing.

## THE PIT AND THE PENDULUM

As the adventurers progress through a dungeon corridor, a pressure-sensitive plate triggers an opening in the floor. The floor falls away to reveal a 10 ft. wide, 20 ft. deep pit interrupting the corridor. The bottom of the pit is filled with spikes. Normally, this would present little challenge to the adventurers, except that a gigantic

pendulum, sharpened on both ends, will fall from the ceiling behind and scythe through the party.

Characters within 10 feet of the pit must make a Reflex Save (DC 20) to avoid being hit by the scythe. Characters who fail the save take 3d6 points of damage and will be knocked forward 5 feet. If this takes them over the edge of the pit, they will plummet to the bottom.

Assuming the characters are not injured or killed by the initial sweep, they must figure out a way across the pit with a nasty, heavy blade sweeping back and forth across their heads. Since they cannot simply cross the pit, characters will have to find a way to jump across to the other side. The safest method is to actually jump onto the scythe (Jump DC 15) and leap off as it reaches the far point of its swing. Failure on this Jump check causes normal scythe damage. This allows the person riding on the scythe to only have to jump a 5-ft. gap.

The pit itself is 10 ft. deep and contains dozens of razor-sharp spikes. Falling into the pit causes 1d6 points of damage from the fall and 1d4 spikes hit the character for 1d6 points of damage each.



# INDEX

A Gift for the Guardian	154-156	Fellbank's Loathsome Lute	35
A Lack of Class	164	Field of Ruin	51-52
Abyssal larvae jelly	134	Fiendish piranha	96
Alcoves	19	Fire Shower	81
All Wrapped Up	8	Firemetal	138-139
An A-mazing Illusion	162	Flame viper venom	151
Anchor venom	145	Flashblind	20
Angelcap	150	Flip Corridor	52-53
Arcanbane	150	Foetid Paste	139
Assassin butter	134	Four Paths	157-158
Autogarrote	93-94	Fragmentation Book	53-54
Avert the Unwanted Hand	117	Froderick's Ensnaring Floor	81-82
Bearmad	135	Froderick's Icy Cubes	128-129
Belted whipvine	150	Froderick's Illusory Floor	36
Black Garden	48	Froderick's Vanishing Levitators	108-109
Blackcat	150	Ghost nettle extract	139
Blackstone's Chained Fist	30-32	Ghost nettle smoke	139
Blind Man's Bluff	78-79	Giant Sucking Sound	82-83
Bloody Slope	165	Giant's Step	68-69
Blue coldmoss	150	Goblin spit	151
Blue death	135	Golem's bane	146
Bookcover Blade Trap	32-33	Gore-Eye's Elevator	83-84
Borbus berry juice	150	Gore-Eye's Piledriver	84-86
Brago's Anger	48-49	Gore-eye's treat	139
Breathtaking Corridor	49-50	Grenade Chest	98-99
Bronze Dragon Trap	127	Guard Duty	158
Burning Breath	80-81	Guard SpooF	86
Burning Wall	94-95	Hall of Daggers	21
Cat's Claw	33-34	Hand It Over	117-118
Challenges	164-168	Hangman's Last Laugh	11-12
Chokehall	66-67	Have a Seat	54
Cloak and Dagger	8-9	Hellblood venom	140
Cockatrice feather	150	Hidden Door Misdirection	22
Cockatrice yolk	148-149	Hunter's friend	146
Cold Feet	95-96	Ice moccasin venom	151
Collapsing Ladder	20	Ichor of chaos	146-147
Coward's bane	135	Illusory Oublette	120
Crossfire	10	Impaling Tree	36-37
Crypt smoke candle	135-136	Improperly Stored Chemicals	163
Crystal Case Trap	104-105	Infectious Melody	37
Crystalweed	151	Ink Mine	12-13
Cutfoot Bridge	119	Intoxication, new condition	153
Darkmetal Clawtrap	50-51	Jaw Box	69-70
Deadly Grove	103-104	Jaw Gate	54-55
Death glass	136	Jester's Game	86-87
Deepcavern tar	151	Jester's rash	140
Defense Arcana	67	Jump Trick	22-23
Demonbane	149	Kali's Kiss	109-110
Dial an Entrance	156	Killing Kiln	90
Die-ing for the Answer	157	Kinslayer draught	147
Dire amber	136-137	Kiss of the aboleth	149
Dire urchin spine	137	Kruh'rag	140
Disarmed and Dangerous	96-97	Laburnum oil	152
Door Jam	34	Lame, new condition	69
Drop and Blade Crawl	97-98	Large-scale traps	6
Drop and Slice	105-106	Leg Shredder	23-24
Drowning Maiden	106	Light Burst	70
Duck and Cover	127-128	Light sensor tools	25
Dust to dust	145-146	Lightning and Mirrors	37
Elemental toxin, air	137	Longpit	13
Elemental toxin, earth	137	Lotus vinegar	140
Elemental toxin, fire	138	Magic Falling Block	99-100
Elemental toxin, water	138	Magic poisons	145-148
Elf Mire	67-68	Magnetic Wall	38-39
Eye-killer	138	Mantle of Dread	13-14
Falling Wall	107-108	Master's draught	147
Fantastic Bridge	165-166	Meal Spears	14
Feeding the Animals	158	Metal Sickness	138
Fellbank's Deadly Instruments	34-35	Metalseep gas	141
Fellbank's Dulcimer of Doom	35	Misdirected Mechanism	71

# INDEX

Mist of the fatigued	141	Stilted Wall	59-60
Mogro's Coop	71-72	Stinkhorn	153
Mogro's Spring-Loaded Slayer	39	Stormchased	89
Monstrous poisons	148-150	Strip	103
Mouthing eyes	141	Suffer dust	143
Mud Collapse	72	Sun's scorn	143-144
Mummy!	163	Supernatural poisons	145-148
No Exit	120-121	Surgeon's root	144
No Fly Zone	39-40	Surprising Blades	89-90
Numbwrack	141	Swinging Platforms	167
Oil of order	147	Sylvan Springspike	60-61
One Problem with Shooting First	163	Tagis root shavings	153
One Rug, Slightly Used	72-73	Tamarack	153
Orc essence	152	Tentacle Terror	61
Outdoor traps	6	The Acid Path	113-114
Paladin's Bane	55	The Avalanche	114-115
Palsy root extract	141	The Collapsing Rope Bridge	167
Pebbles	159	The Crypt	30
Pepper dust	152	The Doorway to Madness	162-163
Perivax's Chambers of Eternal Slumber	132	The False Door	17
Perivax's Chemical Chaos	100	The Good Samaritan	17-18
Perivax's Crushing Bands	55-56	The Grinning Skull	43
Perivax's Wicked Water	121-122	The Key to Success	160
Personal Darkness	24	The Open Grave	74-75
Pickle toad	152	The Orc Crusher	124
Pillar of Sharp Air	100-101	The Pit and the Pendulum	168
Pillar Squeeze	122-123	The Plummeting Room	61-62
Pink smiles	147-148	The Poisoned Stone	43-44
Pit Gallery	40	The Rod of King Jhaerith V	161
Pit of Broken Statues	87-88	The Sinister Stairs	75-76
Poison rarity	133-134	The Spinning Tunnel	76-77
Pooling breather	141-142	The Sticky Slap	115-116
Power Saw Corridor	110-112	Time's Up	44
Prankster poisons	150-153	Tomb of Ice	118-119
Pudding bean	149-150	Trap enhancements	6-8
Pulling the Pin	73-74	Trap Key Trick	62-63
Purple mushroom	152	Trick Coin	30
Quiet Blanket	102	Tricks	162-163
Razor Mesh	56-57	Trogoil	144
Rogue's rouge	142	Turkey Shoot	63-64
Roller Pit	112-113	Turn the Invader	18-19
Room of Cunning Observation	14-15	Ulatein	144-145
Rubie Flower	15-16	Undead pact	148
Scaly mold	142	Undead's foe	148
Scarejuice	142	Unhinged Wall	124-125
Scarlet Howler	24-26	Unicorn tears	153
Screaming Armor	102-103	Up and Away	90-91
Seeper Trap	27	Vampiric draught	150
Shadow ink	148	Varlet Vice	44-45
Silent whisper	142	Vengeance Unleashed	45-46
Slide Room	26-27	Vermin Pit	46
Slippery Stairs	16-17	Vertigo	145
Snap Trap	28	Vesher's Killing Cube	46-47
Snare Toss	57-58	Vesher's Vicious Grinder	129-130
Sower of Chaos	40-41	Violet X	145
Spider on the Bridge	41-42	Wall Crawler Chaos	64-65
Spiked Stairs	58-59	Waltzing Tunnel	77
Spindle shrub	152-153	Warded Repose	116
Spindle Sprayer	59	Web of Lies	126
Spinning Target	166-167	Well of Tentacles	130-131
Spiny toadstool	142-143	Wheel of Woe	161
Sprayed Surprise	17	Which Way	65-66
Spring and Winter	88-89	Winch sap	153
Square Pegs	159-160	Wind Moat	92-93
Staircase moss	153	Withering draught	148
Standard poisons	134-145	Wizard's bane	145
Steam Tunnel	123-124		
Step in Blast	42-43		
Sticky Situation	29		
Stiffjoint	143		

# TRAP LIST BY CR

## MECHANICAL TRAPS

### CHALLENGE RATING 1

Cloak and Dagger	8
Crossfire	10
Hangman's Last Laugh	11
Ink Mine	12
Longpit	13
Meal Spears	14
Ruby Flower	15
Slippery Stairs	16
The False Door	17

### CHALLENGE RATING 2

Alcoves	19
Collapsing Ladder	20
Flashblind	20
Hall of Daggers	21
Hidden Door Misdirection	22
Leg Shredder	23
Scarlet Howler	24
Slide Room	26
Seeper Trap	27
Snap Trap	28
Sticky Situation	29
The Crypt	30
Trick Coin	30

### CHALLENGE RATING 3

Blackstone's Chain Fist	30
Bookcover Blade Trap	32
Cat's Claw	33
Door Jam	34
Fellbank's Dulcimer of Doom	35
Froderick's Illusory Floor	36
Mogro's Spring-Loaded Slayer	39
Pit Gallery	40
The Grinning Skull	43
The Poisoned Stone	43
Time's Up	44
Varlet Vise	44
Vesher's Killing Cube	46

### CHALLENGE RATING 4

Brago's Anger	48
Breathtaking Corridor	49
Darkmetal Clawtrap	50
Flip Corridor	52
Fragmentation Book	53
Jaw Gate	54
Paladin's Bane	55
Perivax's Crushing Bands	55
Razor Mesh	56
Snare Toss	57
Spiked Stairs	58
Spindle Sprayer	59
Stilted Wall	59
Sylvan Springspike	60
The Plummeting Room	61
Trap Key Trick	62
Turkey Shoot	63

Wall Crawler Chaos	64
--------------------	----

### CHALLENGE RATING 5

Chokehall	66
Giant's Step	68
Jaw Box	69
Light Burst	70
Mogro's Coop	71
Pulling the Pin	73
The Open Grave	74
The Sinister Stairs	75
The Spinning Tunnel	76
Waltzing Blades	77

### CHALLENGE RATING 6

Blind Man's Bluff	78
Burning Gaze	80
Fire Shower	81
Giant Sucking Sound	82
Gore Eye's Elevator	83
Gore Eye's Piledriver	84
Jester's Game	86
Pit of Broken Statues	87
The Killing Kiln	90
Up and Away	90

### CHALLENGE RATING 7

Autogarrote	93
Burning Wall	94
Drop and Blade Crawl	97
Grenade Chest	98
Perivax's Chemical Chaos	100
Pillar of Sharp Air	100
The Deadly Grove	103

### CHALLENGE RATING 8

Crystal Case Trap	104
Drop and Slice	105
Falling Wall	107
Kali's Kiss	109
Power Saw Corridor	110
Roller Pit	112
The Acidic Path	113
The Avalanche	114
The Sticky Slap	115

### CHALLENGE RATING 10+

Cutfoot Bridge	119
No Exit	120
Perivax's Wicked Water	121
Pillar Squeeze	122
Steam Tunnel	123
The Orc Crusher	124
Unhinged Wall	124
Web of Lies	126
Duck and Cover	127
Vesher's Vicious Grinder	129

# TRAP LIST BY CR

## MAGIC TRAPS

### CHALLENGE RATING 1

All Wrapped Up	8
Mantle of Dread	13
Room of Cunning Observation	14
Sprayed Surprise	17
The Good Samaritan	17
Turn the Invader	18

### CHALLENGE RATING 2

Jump Trick	22
Personal Darkness	24

### CHALLENGE RATING 3

Fellbank's Loathsome Lute	35
Impaling Tree	36
Infectious Melody	37
Lightning and Mirrors	37
Magnetic Wall	38
No Fly Zone	39
Sower of Chaos	40
Spider on the Bridge	41
Step In Blast	42
Vengeance Unleashed	45
Vermin Pit	46

### CHALLENGE RATING 4

Black Garden	48
Field of Ruin	51
Have a Seat	54
Tentacle Terror	61
Which Way	65

### CHALLENGE RATING 5

Defense Arcana	67
Elf Mire	67
Misdirected Mechanism	71
Mud Collapse	72
One Rug, Slightly Used	72

### CHALLENGE RATING 6

Froderick's Ensnaring Floor	81
Guard Spoof	86
Spring and Winter	88
Stormchased	89
Surprising Blades	89
Wind Moat	92

### CHALLENGE RATING 7

Cold Feet	95
Disarmed and Dangerous	96
Magic Falling Block	99
Quiet Blanket	102
Screaming Armor	102
Strip	103

### CHALLENGE RATING 8

Drowning Maiden	106
Froderick's Vanishing Levitators	108
Warded Repose	116

### CHALLENGE RATING 9

Avert the Unwanted Hand	117
Hand It Over	117
Tomb of Ice	119

### CHALLENGE RATING 10

Illusory Oubliette	120
Bronze Dragon Trap	127
Froderick's Icy Cubes	128
Well of Tentacles	132
Perivax's Chambers of Eternal Slumber	132

# LEGENDS & LAIRS™

Available  
May 2002

## Essential



Available  
Now

ALSO  
AVAILABLE  
DD17 Traps & Treachery  
DD18 Mythic Races



Available  
Now



- Sequel to the bestselling Traps & Treachery
- Over 90 new highly detailed mechanical and magical traps
- Scores of new magical and mundane poisons
- Dozens of incredible new puzzles and challenges

DD 29 Hardcover 176 pages SRP \$24.95

- More than 100 new arcane and divine spells
- Several new magic systems, three new magic item types, and dozens of new magic items
- Rules for customizing familiars, creating powerful divine rituals, and building unique constructs and golems
- Rules for alchemical and magical research, laboratories, and libraries

DD 28 Hardcover 176 pages SRP \$24.95

- Detailed descriptions and deck plans of all sorts of ships, from longships to war galleons
- Complete d20 System rules for naval combat and boarding actions
- Guidelines for creating undersea adventures and resolving aquatic encounters
- New nautical feats, prestige classes, spells, magic items, equipment, and monsters

DD 27 Hardcover 176 pages SRP \$24.95



# RAISE YOUR GAME!

# WINTER IS COMING



# A GAME OF THRONES

Collectible Card Game

# AUGUST 2002

A Game of Thrones TM & © George R. R. Martin  
A Game of Thrones CCG TM & © 2002 FFG



# CITADELS™

## RULE TO LIVE, LIVE TO RULE

### A GAME OF MEDIEVAL CITIES, NOBLES AND INTRIGUE

Nominated for the German GAME OF THE YEAR in 2000, CITADELS has finally arrived in an English language edition. Game enthusiasts of all genres will be enchanted by this wonderful card game of bluffing, deduction, and city-building. Wrapped in a Medieval theme and gorgeously illustrated, the game is won by the first player to complete a grand city of his own. Each game round players secretly take the roles of the King, Magician, Architect, Assassin, Thief, Bishop, General, or Merchant and seek to use the powers of such offices in their efforts to win the game.

As an additional bonus, the English version will ship with 10 new cards designed by Bruno Falducci. These cards feature new locations and new characters to make your game of CITADELS even more diverse than the original German version.

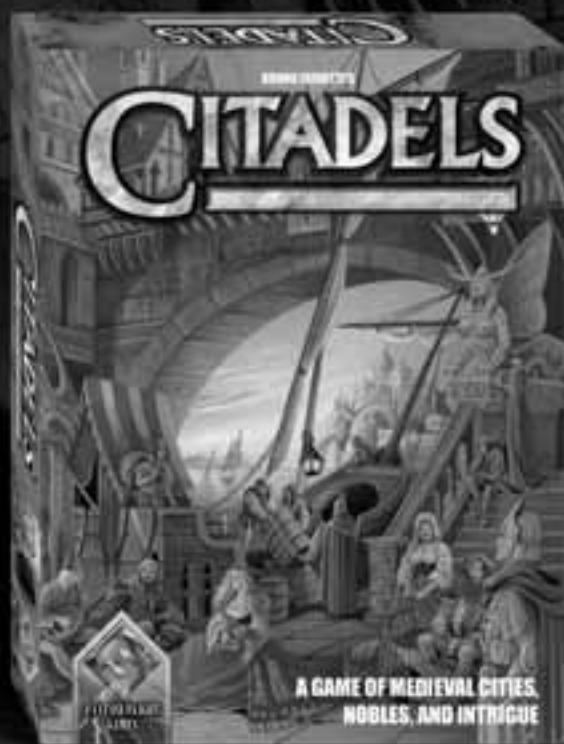

CITADELS card game MA04 \$19.95





## **OPEN GAME LICENSE Version 1.0a**

The following text is the property of Wizards of the Coast, Inc. and is Copyright 2000 Wizards of the Coast, Inc (“Wizards”). All Rights Reserved.

1. Definitions: (a) “Contributors” means the copyright and/or trademark owners who have contributed Open Game Content; (b) “Derivative Material” means copyrighted material including derivative works and translations (including into other computer languages), potation, modification, correction, addition, extension, upgrade, improvement, compilation, abridgment or other form in which an existing work may be recast, transformed or adapted; (c) “Distribute” means to reproduce, license, rent, lease, sell, broadcast, publicly display, transmit or otherwise distribute; (d) “Open Game Content” means the game mechanic and includes the methods, procedures, processes and routines to the extent such content does not embody the Product Identity and is an enhancement over the prior art and any additional content clearly identified as Open Game Content by the Contributor, and means any work covered by this License, including translations and derivative works under copyright law, but specifically excludes Product Identity. (e) “Product Identity” means product and product line names, logos and identifying marks including trade dress; artifacts; creatures characters; stories, storylines, plots, thematic elements, dialogue, incidents, language, artwork, symbols, designs, depictions, likenesses, formats, poses, concepts, themes and graphic, photographic and other visual or audio representations; names and descriptions of characters, spells, enchantments, personalities, teams, personas, likenesses and special abilities; places, locations, environments, creatures, equipment, magical or supernatural abilities or effects, logos, symbols, or graphic designs; and any other trademark or registered trademark clearly identified as Product identity by the owner of the Product Identity, and which specifically excludes the Open Game Content; (f) “Trademark” means the logos, names, mark, sign, motto, designs that are used by a Contributor to identify itself or its products or the associated products contributed to the Open Game License by the Contributor (g) “Use”, “Used” or “Using” means to use, Distribute, copy, edit, format, modify, translate and otherwise create Derivative Material of Open Game Content. (h) “You” or “Your” means the licensee in terms of this agreement.

2. The License: This License applies to any Open Game Content that contains a notice indicating that the Open Game Content may only be Used under and in terms of this License. You must affix such a notice to any Open Game Content that you Use. No terms may be added to or subtracted from this License except as described by the License itself. No other terms or conditions may be applied to any Open Game Content distributed using this License.

3. Offer and Acceptance: By Using the Open Game Content You indicate Your acceptance of the terms of this License.

4. Grant and Consideration: In consideration for agreeing to use this License, the Contributors grant You a perpetual, worldwide, royalty-free, non-exclusive license with the exact terms of this License to Use, the Open Game Content.

5. Representation of Authority to Contribute: If You are contributing original material as Open Game Content, You represent that Your Contributions are Your original creation and/or You have sufficient rights to grant the rights conveyed by this License.

6. Notice of License Copyright: You must update the COPY-RIGHT NOTICE portion of this License to include the exact text of the COPYRIGHT NOTICE of any Open Game Content You are copying, modifying or distributing, and You must add the title, the copyright date, and the copyright holder’s name to the COPYRIGHT NOTICE of any original Open Game Content you Distribute.

7. Use of Product Identity: You agree not to Use any Product Identity, including as an indication as to compatibility, except as expressly licensed in another, independent Agreement with the owner of each element of that Product Identity. You agree not to indicate compatibility or co-adaptability with any Trademark or Registered Trademark in conjunction with a work containing Open Game Content except as expressly licensed in another, independent Agreement with the owner of such Trademark or Registered Trademark. The use of any Product Identity in Open Game Content does not constitute a challenge to the ownership of that Product Identity. The owner of any Product Identity used in Open Game Content shall retain all rights, title and interest in and to that Product Identity.

8. Identification: If you distribute Open Game Content You must clearly indicate which portions of the work that you are distributing are Open Game Content.

9. Updating the License: Wizards or its designated Agents may publish updated versions of this License. You may use any authorized version of this License to copy, modify and distribute any Open Game Content originally distributed under any version of this License.

10. Copy of this License: You MUST include a copy of this License with every copy of the Open Game Content You Distribute.

11. Use of Contributor Credits: You may not market or advertise the Open Game Content using the name of any Contributor unless You have written permission from the Contributor to do so.

12. Inability to Comply: If it is impossible for You to comply with any of the terms of this License with respect to some or all of the Open Game Content due to statute, judicial order, or governmental regulation then You may not Use any Open Game Material so affected.

13. Termination: This License will terminate automatically if You fail to comply with all terms herein and fail to cure such breach within 30 days of becoming aware of the breach. All sublicenses shall survive the termination of this License.

14. Reformation: If any provision of this License is held to be unenforceable, such provision shall be reformed only to the extent necessary to make it enforceable.

## **15. COPYRIGHT NOTICE**

Open Game License v 1.0 Copyright 2000, Wizards of the Coast, Inc.

System Reference Document Copyright 2000, Wizards of the Coast, Inc.; Authors Jonathan Tweet, Monte Cook, Skip Williams, based on original material by E. Gary Gygax and Dave Arneson.

Traps & Treachery II Copyright 2002, Fantasy Flight, Inc.

# TRAPS & TREACHERY II

**The characters might rest between adventures, but their adversaries don't....**

- More than 150 complete descriptions of magic and mechanical traps
- Dozens of beautiful illustrations detailing the mechanisms behind these sinister creations
- Tricks and techniques for making traps even more difficult to bypass
- Rules for poison rarity, two new types of poisons, and more than 80 detailed listings of new poisons, natural and supernatural alike
- A chapter devoted to unique puzzles and challenges to test the abilities of both the players and their characters

*“Traps & Treachery is a proud addition to my gaming shelf. You should go and buy this book.”*

Monte Cook, Game Designer, Malhavoc Press



ISBN 1-58994-027-X



52495

DD29

\$24.95

**FANTASY  
FLIGHT  
GAMES**



[www.fantasyflightgames.com](http://www.fantasyflightgames.com)